

Looking ahead,
going beyond expectations
Ahead > Beyond

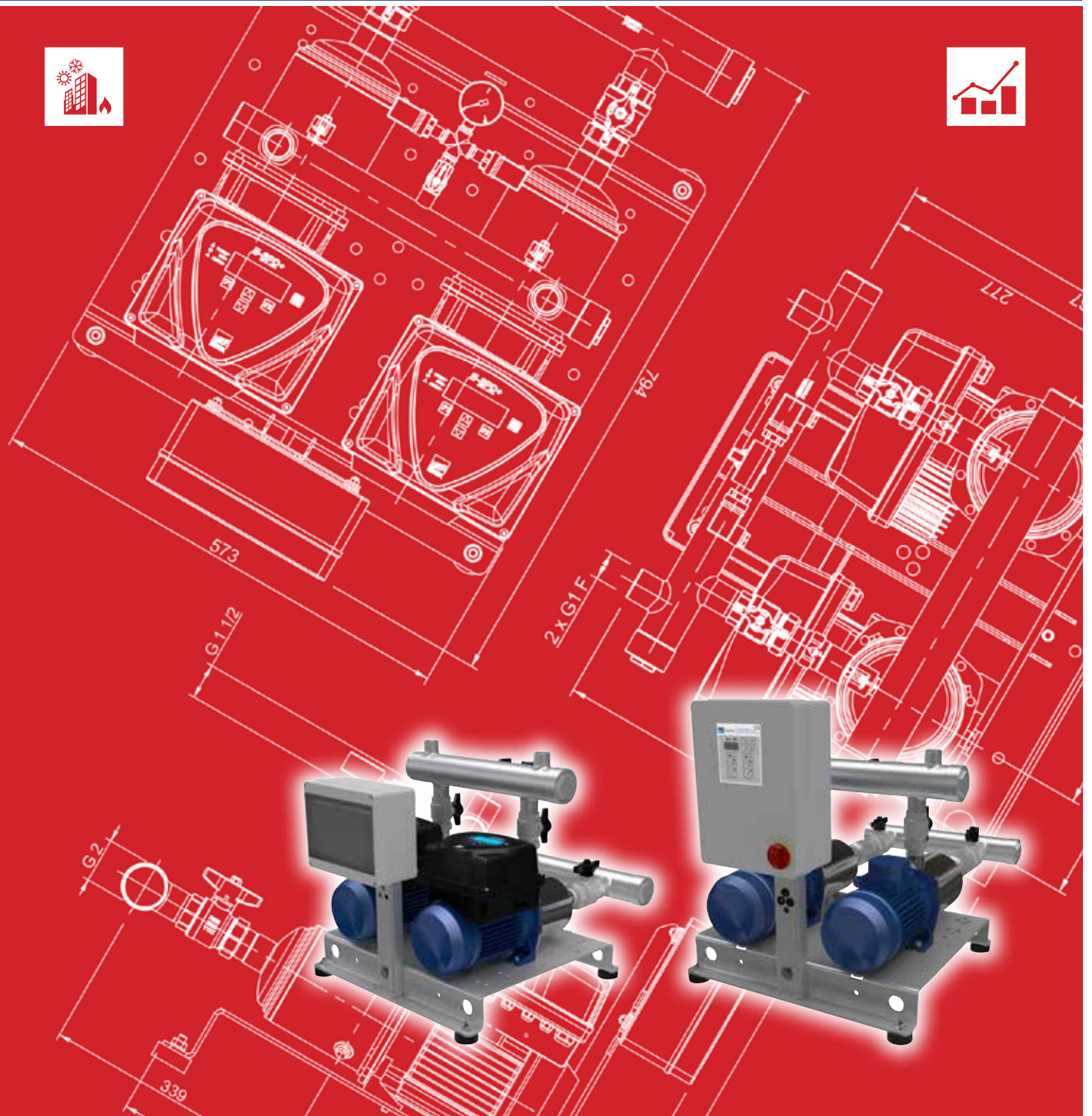

GP - GPE MATRIX

Data Book 50Hz



INDEX

	Page
INDEX	2
DEFINITION AND USE OF PRESSURISATION UNITS	101
TYPICAL APPLICATIONS	101
OPERATING CONDITIONS	101
TESTS AND TRIALS	101
MECHANICAL AND HYDRAULIC TESTS	101
ELECTRICAL TESTS	102
PRINCIPLE OF OPERATION OF GP PRESSURISATION UNITS	102
Principle of Operation of GPE Pressurisation UNITS with E-SPD+	102
Principle of Operation of GPE Pressurisation UNITS with an EFC control panel	102
Principle of Operation of GPE Pressurisation UNITS with an MFC control panel	103
Fig. 1 - TWO PUMP UNIT WITH CONSTANT PRESSURE REGULATION	104
GP PRESSURISATION UNIT WATER CIRCUIT DIAGRAM	104
GPE PRESSURISATION UNIT WATER CIRCUIT DIAGRAM	105
TYPE KEY	106
NAME PLATE	106
PRODUCT SPECIFICATIONS	201
HYDRAULIC COMPONENTS AND CONTROL	201
ELECTRIC PANEL	202
TECHNICAL PUMP DATA	203
TECHNICAL MOTOR DATA	204
PERFORMANCE RANGE	301
RESEAU BOOSTER SET 2GP(.) MATRIX	301
CURVE SPECIFICATION 2GP(.)	401
SELECTION CHART 2GP(.) MATRIX	402
PERFORMANCE CURVE 2GP(.)	403
2GP(.) MATRIX 3-4T/0.65	403
2GP(.) MATRIX 3-5T/0.75	404
2GP(.) MATRIX 3-6T/0.9	405
2GP(.) MATRIX 3-7T/1.3	406
2GP(.) MATRIX 3-8T/1.3	407
2GP(.) MATRIX 3-9T/1.5	408
2GP(.) MATRIX 5-3T/0.65	409
2GP(.) MATRIX 5-4T/0.9	410
2GP(.) MATRIX 5-5T/1.3	411
2GP(.) MATRIX 5-6T/1.3	412

2GP(.) MATRIX 5-7T/1.5	413
2GP(.) MATRIX 5-8T/2.2	414
2GP(.) MATRIX 5-9T/2.2	415
2GP(.) MATRIX 10-3T/1.3	416
2GP(.) MATRIX 10-4T/1.5	417
2GP(.) MATRIX 10-5T/2.2	418
2GP(.) MATRIX 10-6T/2.2	419
2GP(.) MATRIX 18-3T/2.2	420
2GP(.) MATRIX 18-4T/3	421
2GP(.) MATRIX 18-5T/4	422
2GP(.) MATRIX 18-6T/4	423
2GP CONSTRUCTION	601
EXTERNAL VIEW 2GP MATRIX	601
EXTERNAL VIEW 2GPE MATRIX E-SPD+	602
OVERALL DIMENSIONS 2GP BOOSTER SET	603
2GP MATRIX	603
2GPE MATRIX 3-5-10 E-SPD+	604
PACKING	605
2GP MATRIX SINGLE PHASE	605
2GP MATRIX THREE PHASE	606
2GPE MATRIX	606
CONTROL PANEL FIXED SPEED	801
2EP-E SPECIFICATION	801
CONTROL PANEL VARIABLE SPEED	803
E-SPD+ SPECIFICATION	803
SP (EFC and MFC) SPECIFICATION	804
PROTECTION PANEL SPECIFICATION	807

DEFINITION AND USE OF PRESSURISATION UNITS

In situations in which a municipal water mains is lacking or insufficient for the proper operation of the services, one must install a pressurization unit to provide acceptable pressure and flow rates to even in the most unfavourable services. Pressurisation units are used wherever there is a need to increase the pressure, or to pressurise a water circuit. **EBARA GP pressurisation units** are automatic systems with 2 or more pumps operating in parallel, designed to provide a simple and reliable solution to the most common requirements for maintenance of water supply pressure for apartment buildings, hotels, centres, offices and schools as well as providing auxiliary service in industrial and agricultural applications. They stand out for their robust construction, compact size, excellent efficiency and silent operation. GP units are equipped for connection to membrane and air cushion autoclaves. They are controlled by pressure transmitter for EP-E and by pressure switches for EP. GPE units (with INVERTER) are controlled by pressure transmitter.

TYPICAL APPLICATIONS

INDUSTRY	BUILDING SERVICE	WATER SUPPLY
		

OPERATING CONDITIONS

EBARA GP-GPE pressurisation units can be used, in their standard versions, for civil, industrial and agricultural applications, as follows:

- building service
- water lifting and handling
- A/C
- heating
- irrigation
- washing systems

The conveyed fluid must be: clean, potable, ground or mixed water, free of solid or fibrous suspensions and aggressive chemical substances.

The units must be installed under cover, protected from the weather and freezing.

- Conveyed water temperature (depending on pumps).
- Ambient operating temperature 0 - 40°C, no higher than 1000 m above sea level.
- Max relative humidity 50% at +40°C.

NB: The system available NPSH must be greater than the NPSH demanded from the pump. For applications with different technical specifications, uses and climatic conditions (type of vector fluid, marine and aggressive industrial conditions), please contact our sales network.

TESTS AND TRIALS

Before shipping, all EBARA pressurisation units are subject to hydraulic, mechanical and electrical testing.

MECHANICAL AND HYDRAULIC TESTS

- Pressure switch calibration (only if present)
- Pump direction of rotation
- Mechanical testing of moving parts and running noise (on each pump)
- Tightness test with delivery port closed and nameplate rating tests
- MANUAL trials (using button on control panel) for each pump
- AUTOMATIC trials (using switch on control panel) for unit

ELECTRICAL TESTS

- Earthing system continuity
- Applied voltage (dielectric rigidity)
- Insulation resistance

PRINCIPLE OF OPERATION OF GP PRESSURISATION UNITS

When water is demanded, it is first drawn from the autoclave tank (if present). This demand for water, with the pumps stopped, lowers the pressure until the first pressure switch (for EP version) or the pressure transmitter (for EP-E version) starts the first electropump. If the output flow is greater than the delivery capacity of a single pump, the pressure continues falling until the second pressure switch (for EP version) or the pressure transmitter (for EP-E version), thus starting the second pump. This happens for all pumps in the unit. When the water demand stops or reduces, the system pressure rises, the pressure switches (for EP version) or the pressure transmitter (for EP-E version) shutting off the pumps one by one. This is done in inverse order to that in which the motors were started up, the number of hourly starts per pump is reduced and they are all used to the same extent.

NB: By connecting a float switch or minimum pressure switch to the control panel (both for demand from the first accumulation tank and from the water circuit itself) one can prevent the most frequent cause of pump failure: dry running

Principle of Operation of GPE Pressurisation UNITS with E-SPD+

GPE units with E-SPD+ are designed to operate with each pumps controlled by an INVERTER installed on board its motor. The system is controlled by an MASTER INVERTER in relation to the reference signal supply by a pressure transmitters (4 - 20 mA passive). As the system pressure varies, the MASTER pump varies its rotary speed to restore it to the setpoint. If the water demand exceeds the capacity of the pump, the second variable speed pump cuts in and, pump goes into regulation mode to maintain the pressure setpoint; this happens for all the pumps in the unit. If the water demand drops off, the pressure tends to increase and the latest pump gradually reduces its speed to restore the correct operating pressure. This results in the regulation of the speed of the other pumps, until they gradually turn off. Once the system pressure has been restored and the water demand is 0, the MASTER pump switches off automatically.

Principle of Operation of GPE Pressurisation UNITS with an EFC control panel

EFC multiple pump control units power pump n. 1 with the INVERTER to modulate system performance in relation to the reference signal while the other pumps are run at maximum nominal speed (around 2900 rpm) and started and stopped in relation to demand.

These means there are two distinct primary electrical circuits:

- n. 1 - INVERTER startup/control of a single pump,
- n. 2 - contactor startup (direct or star/delta) of the other pumps.

The system is controlled by an electronic controller in relation to the reference signal supply by a pressure transmitter, flow meter or other unified control signal (4 - 20 mA passive).

If the electronic controller or pressure transmitter fails, a system of pressure switches controls the pumps directly (if present).

- In case of water distribution at constant pressure (Fig.1), the electronic controller is connected to the pressure transmitter on the units' delivery manifold, which outputs a signal proportional to the circuit pressure. When the pressure drops due to water demand, the pressure transmitter signal also drops and the controller starts and controls the speed of the first pump with the INVERTER to restore the reference/ operating pressure. If the pump's flow rate is lower than demand, the circuit pressure will continue to drop and the system responds by increasing the pump's speed. Once pump n. 1 reaches its maximum speed and demand is still in excess of its delivery, the controller will start pump n. 2 at maximum speed. The speed of pump n. 1 is immediately modulated so as to establish the operating pressure. If the pressure drops even further and pump n. 1 is once again running at maximum speed, the controller starts up pump n. 3, and so on for all pumps in the unit. If the water demand drops off, the pressure tends to increase and the controller reduces the speed of pump n. 1 to

restore the correct operating pressure. At this point, the controller will stop one of the pumps running at maximum speed, while the speed of pump n. 1 is modulated to maintain the reference pressure. As the pressure continues to increase due to reduced demand, once the minimum speed of pump n. 1 is reached once more the controller will stop pump n. 3 and then pump n. 2. Once the demand for water has completely ceased, the controller reduces the speed of pump n. 1 to its minimum and after a set delay (around 1 minute) stops this pump too. The next time the system is started up, the INVERTER controlled pump will no longer be pump n. 1, but n. 2. The INVERTER controlled pump thus rotates through all pumps in sequence.

Principle of Operation of GPE Pressurisation UNITS with an MFC control panel

MFC multiple pump control panels power each pump with an INVERTER to modulate system performance in relation to the reference signal. MFC controllers differ from EFC controller from the point of view of their construction, since instead of having a single INVERTER to control all the pumps, each pump has its own INVERTER. The two types of control panel differ in construction, but they have the same type of operation by the controller, which responds to the reference signal output by a pressure transmitter or other unified control (4 - 20 mA passive). If the electronic controller or pressure transmitter fails, a system of pressure switches controls the INVERTERS directly.

- In case of water distribution at constant starting pressure (Fig.1), the electronic controller is connected to the pressure transmitter on the units' delivery manifold, which outputs a signal proportional to the circuit pressure. When the pressure drops due to water demand, the pressure transmitter signal also drops and the controller starts and controls the speed of the first pump with the INVERTER to restore the reference/ operating pressure. If the pump's flow rate is lower than demand, the circuit pressure will continue to drop and the system responds by increasing the pump's speed. Once pump n. 1 reaches its maximum speed and demand is still in excess of its delivery, the controller will start pump n. 2, also at variable synchronous speed. The controller will modulate the speed of the two pumps to restore the operating pressure; the modulating frequency is the same for both pumps. If the pressure drops even further and pumps n. 1 and 2 are once again running at maximum speed, the controller starts up pump n. 3, and then pump n. 4, if present. When the water demand is reduced the pressure will end to increase, as does the pressure transmitter output value. The controller thus reduces the speed of pumps n. 1, 2, 3 and 4 (they are all controlled at the same speed) to restore the reference/ operating pressure. If the pumps' flow rate is greater than demand, the circuit pressure will continue to increase and the system responds by decreasing the speed of the pumps until it reaches the minimum speed setting. At this point, the controller will stop pump n. 4, while the speed of pumps n. 1, 2 and 3 is modulated to maintain the reference pressure. As the pressure continues to increase due to reduced demand, once the minimum speed setting is reached again, the controller will stop pump n. 3 and modulate the speed of pumps n. 1 and 2. This continues in sequence as the demand continues to fall, until the unit is completely stopped.

Fig. 1 - TWO PUMP UNIT WITH CONSTANT PRESSURE REGULATION

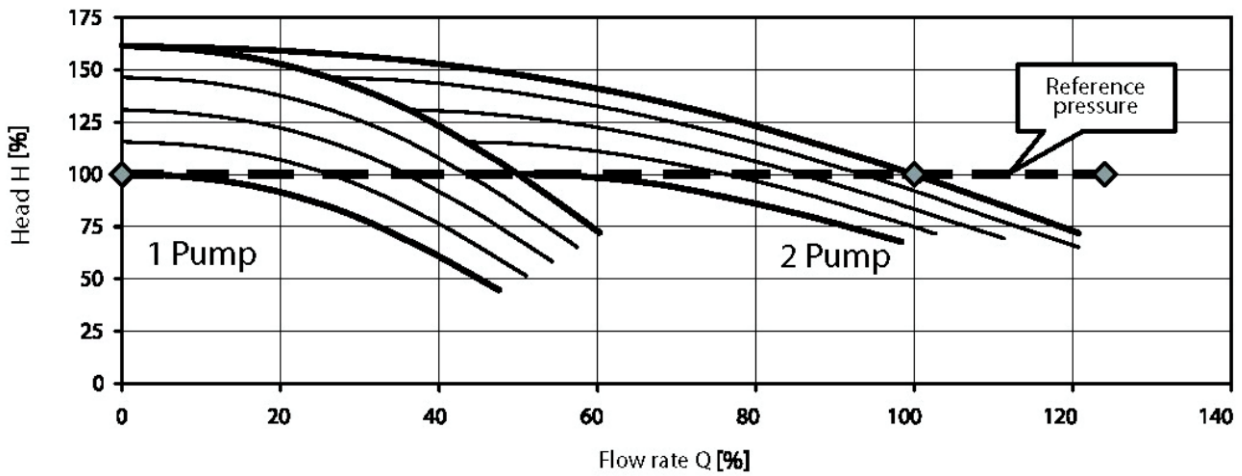

GP PRESSURISATION UNIT WATER CIRCUIT DIAGRAM

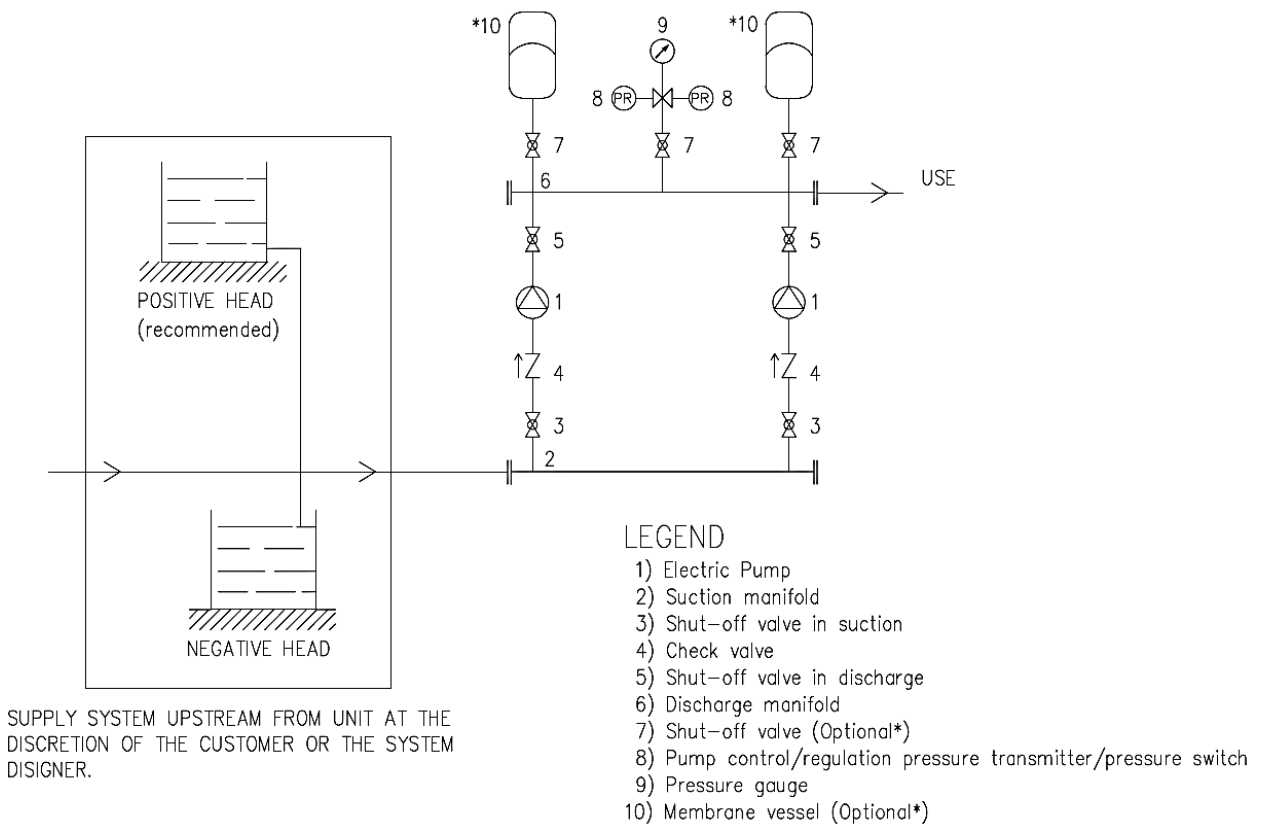

GPE PRESSURISATION UNIT WATER CIRCUIT DIAGRAM

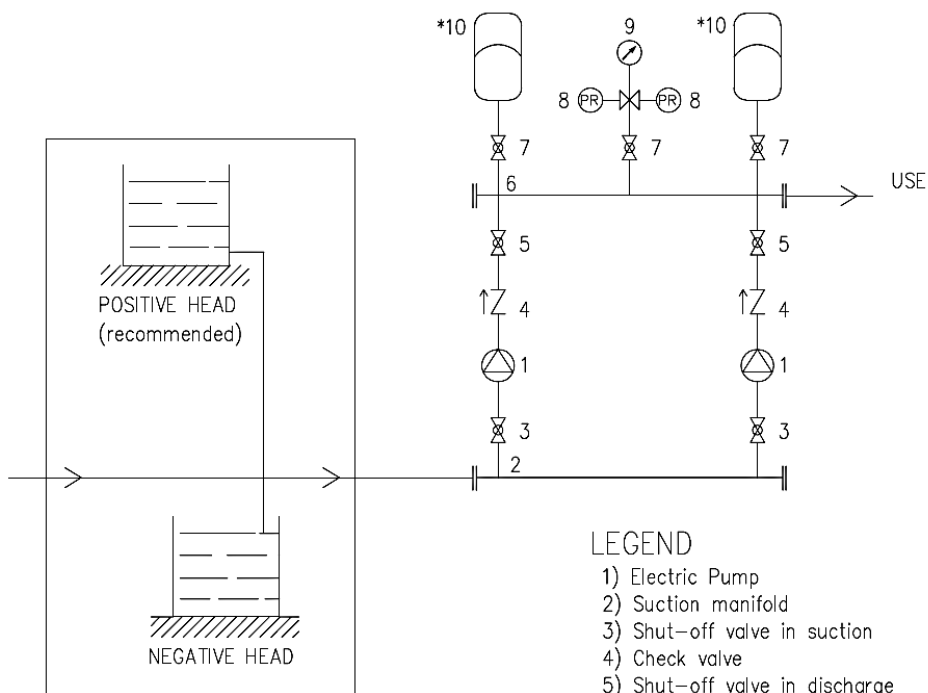

SUPPLY SYSTEM UPSTREAM FROM UNIT AT THE DISCRETION OF THE CUSTOMER OR THE SYSTEM DESIGNER.

LEGEND

- 1) Electric Pump
- 2) Suction manifold
- 3) Shut-off valve in suction
- 4) Check valve
- 5) Shut-off valve in discharge
- 6) Discharge manifold
- 7) Shut-off valve (Optional*)
- 8) Pump control/regulation pressure transmitter/pressure switch
- 9) Pressure gauge
- 10) Membrane vessel (Optional*)

TYPE KEY 2GP(.) MATRIX

2 GPE space MATRIX 5-4T/0,9 M space EFC

Control type

Null = Fixed speed EP-E up to 7,5kW
fixed speed EP from 11kW and above

EFC = Single Inverter SP-EFC

MFC = Multi Inverter SP-EFC

ESPM = E-SPD+ MT (Inlet voltage 230V single phase)

ESPT = E-SPD+ TT (Inlet voltage 400V three phase)

Phase booster

M = Single phase

Null = Three phase

Principal Pump model

Speed

GP = Fixed speed

GPE = Variable speed

Number of principal pump

2

NAME PLATE

 EBARA Pumps Europe S.p.A. Via Campo Sportivo, 30 38023 Cles (TN), ITALY Phone +39 0444 706811 V.A.T.: 01234660221		   MADE IN ITALY
GRUPPO DI PRESSURIZZAZIONE IDRICA		
TYPE	①	
P/N	②	
S/N	③	

- 1) "TYPE" booster model
- 2) "P/N" booster item number
- 3) "S/N" booster serial number

PRODUCT SPECIFICATIONS HYDRAULIC COMPONENTS AND CONTROL

BOOSTER SET						
MATRIX						
Operating range	Version		3	5	10	18
	Nominal flow rate (m ³ /h)	Single pump	3	5	10	18
		2GP(E)	6	10	20	36
	Maximum working pressure		10 bar			
	Liquid temperature range		0 ÷ +80°C [1]			
	Ambient operating temperature (no higher than 1000 m above sea level)		0 ÷ +40°C			
Hydraulic components	Frame		Omega sheet Galvanized steel			
	Manifold suction / discharge		Threaded manifold AISI 304			
	Closing manifold		Threaded female cap AISI 304			
	Check valve		Threaded check valve Brass / NBR			
	Ball valve		Threaded ball valve Brass / PTFE			
	Socket for air feeders (only for "GP" version)		Threaded socket Brass			
Control	Pressure gauge		M3A-ABS 50/FR / plastic-copper alloy			
	Pressure switches		Only for GPE version with SP EFC / MFC panel with inverter XMP / -25°C...+70°C			
	Pressure transmitter		GP version with EP-E panel fixed speed GPE version with SP EFC / MFC panel GPE version with E-SPD+ EN 10088-1.4301 (AISI 304) / 1.4404 (AISI 316L)			

[1] For optional version ask the temperature range to the sales department.

ELECTRIC PANEL

BOOSTER SET						
MATRIX						
Operating range	Version		3	5	10	18
	Nominal flow rate (m3/h)	Single pump	3	5	10	18
		2GP (E)	6	10	20	36
Control panel	Principal Electric panel	EP-E fixed speed (only for GP)	●	●	●	●
		SP EFC/MFC variable speed (only for GPE)	○	○	○	○
	E-SPD+ [1]	ESPDM single-phase supply inverter (only for GPE up to 1.3 kW)	●	●	●	○
		ESPDT three-phase supply inverter (only for GPE up to 2.2 kW)	●	●	●	○

● : Standard ○ : Optional

[1] To be assemble with protection panel (to see "PROTECTION PANEL" section)

TECHNICAL PUMP DATA

PUMP					
MATRIX					
Operating range	Version	3	5	10	18
	Maximum working pressure	1 MPa (10 bar)			
	Liquid temperature range	-15°C to +85°C			
Liquid handled	Liquid type	Water, moderate aggressive solutions, glycol solutions, moderate viscous fluids			
Key components material	Casing	EN 1.4301 (AISI 304)			
	Impeller				
	Casing cover				
	Shaft seal	Ceramic/Carbon/EPDM			
	Shaft	EN 1.4301 (AISI 304) wet extension			
Bracket	EN AB-AISI11Cu2(Fe) (Die cast Aluminium)				
Pipe connection	Suction	G 1"	G 1" ¼	G 1" ½	G 2"
		UNI ISO 228			
	Discharge	G 1"	G 1" ¼	G 1" ½	
		UNI ISO 228			

TECHNICAL MOTOR DATA

MOTOR MATRIX			
Power source	Frequency	50 Hz	
	Phase	Single-phase Three-phase	
	Rotation speed	2850 min ⁻¹	
	Power rating	0.65 ÷ 2.2 kW	0.65 ÷ 4.0 kW
		0.9 ÷ 3.0 HP	0.9 ÷ 5.5 HP
Voltage	230 ± 10% V	230/400 ± 10%	
Type	Type	Electric - TEFC	
	Efficiency level	- IE3 from 0.45 kW up to 4.0 kW	
	N° of poles	2	
	Protection degree	IP 55	
	Insulation class	F	
Others	Capacitor	Built in -	
	Overload protection	Built in Provided by the user	
	Casing Material	Aluminium	
	Motor support	Aluminium	

PERFORMANCE RANGE RESEAU BOOSTER SET 2GP(.) MATRIX

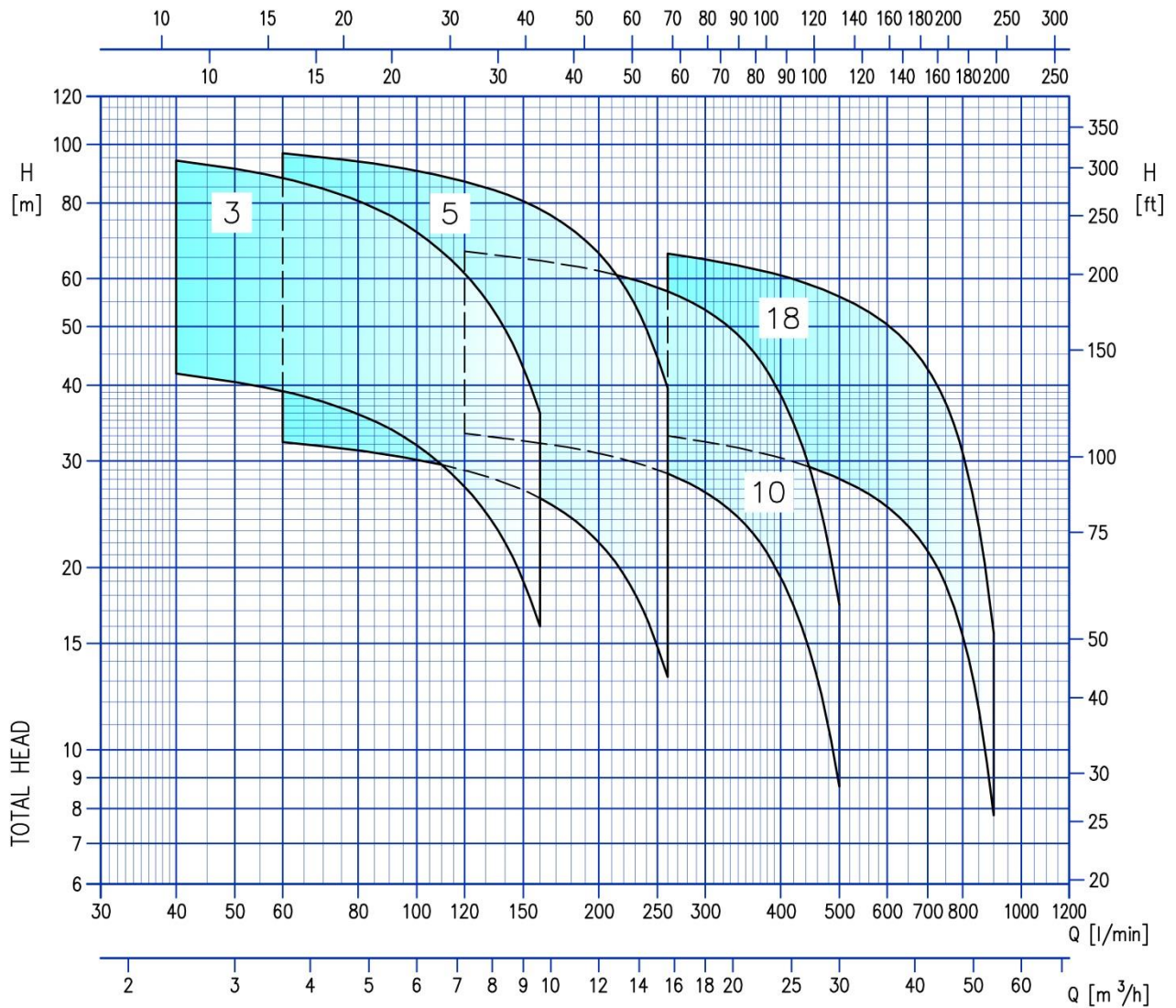

CURVE SPECIFICATION 2GP(.)

The specifications below qualify the curves shown on the following pages.

Tolerances according to ISO 9906:2012 – Grade 3B.

The curves refer to effective speed of asynchronous motors at 50 Hz 2 poles

Measurements were carried out with clean water at 20°C of temperature and with a kinematic viscosity of $\nu = 1 \text{ mm}^2/\text{s}$ (1 cSt).

The NPSH curve is an average curve obtained in the same conditions of performance curves.

During the pump selection, consider to get a safety margin of at least 0.5 m.

The continuous curves indicate the recommended working range. The dotted curve is only a guide.

In order to avoid the risk of over-heating, the pumps should not be used at a flow rate below 10% of best efficiency point. The performance curves refer to 2 pumps booster sets.

Symbols explanation:

Q = volume flow rate

H = total head

P2 = pump power input (shaft power)

η = pump efficiency

NPSH = net positive suction head required by the pump

1 = one pump on work performance curve

2 = two pumps on work performance curve

Pressure drops of the booster's fittings are not considered

SELECTION CHART 2GP(.) MATRIX

Model	Motor		Maximum working pressure (MPa)	Q=Capacity															
	kW	HP		l/min	40	60	90	120	160	200	260	320	400	500	600	700	800	900	
				m ³ /h	2.4	3.6	5.4	7.2	9.6	12.0	15.6	19.2	24.0	30.0	36.0	42.0	48.0	54.0	
				H=Total manometric head in meters															
2GP(.) MATRIX 3-4/0.65	0.65+0.65	0.9+0.9	1.0	45.0	42.0	39.1	34.0	27.2	16.0	-	-	-	-	-	-	-	-	-	
2GP(.) MATRIX 3-5/0.75	0.75+0.75	1.0+1.0		56.5	52.5	49.0	42.5	34.0	20.0	-	-	-	-	-	-	-	-	-	
2GP(.) MATRIX 3-6/0.9	0.9+0.9	1.2+1.2		68.0	62.5	58.5	51.0	41.0	24.0	-	-	-	-	-	-	-	-	-	
2GP(.) MATRIX 3-7/1.3	1.3+1.3	1.8+1.8		79.0	73.0	68.5	59.5	47.5	28.0	-	-	-	-	-	-	-	-	-	
2GP(.) MATRIX 3-8/1.3	1.3+1.3	1.8+1.8		90.5	83.5	78.0	68.0	54.5	32.0	-	-	-	-	-	-	-	-	-	
2GP(.) MATRIX 3-9/1.5	1.5+1.5	2+2		102.0	94.0	88.0	76.5	61.0	36.0	-	-	-	-	-	-	-	-	-	
2GP(.) MATRIX 5-3/0.65	0.65+0.65	0.9+0.9		34.5	-	32.3	30.7	29.0	26.0	22.0	13.2	-	-	-	-	-	-	-	
2GP(.) MATRIX 5-4/0.9	0.9+0.9	1.2+1.2		46.0	-	43.0	41.0	38.6	34.7	29.4	17.6	-	-	-	-	-	-	-	
2GP(.) MATRIX 5-5/1.3	1.3+1.3	1.8+1.8		57.5	-	54.0	51.0	48.5	43.5	36.7	22.0	-	-	-	-	-	-	-	
2GP(.) MATRIX 5-6/1.3	1.3+1.3	1.8+1.8		69.0	-	64.5	61.5	58.0	52.0	44.0	26.4	-	-	-	-	-	-	-	
2GP(.) MATRIX 5-7/1.5	1.5+1.5	2+2		80.5	-	75.5	72.0	67.5	61.0	51.5	30.8	-	-	-	-	-	-	-	
2GP(.) MATRIX 5-8/2.2	2.2+2.2	3+3		92.0	-	86.0	82.0	77.0	69.5	58.5	35.2	-	-	-	-	-	-	-	
2GP(.) MATRIX 5-9/2.2	2.2+2.2	3+3		104.0	-	97.0	92.0	87.0	78.0	66.0	39.6	-	-	-	-	-	-	-	
2GP(.) MATRIX 10-3/1.3	1.3+1.3	1.8+1.8		0.8	36.0	-	-	-	33.3	32.1	30.9	28.6	25.5	19.3	8.7	-	-	-	
2GP(.) MATRIX 10-4/1.5	1.5+1.5	2.0+2.0	48.0		-	-	-	44.5	43.0	41.0	38.1	34.0	25.7	11.6	-	-	-		
2GP(.) MATRIX 10-5/2.2	2.2+2.2	3.0+3.0	60.0		-	-	-	55.5	53.5	51.5	47.5	42.5	32.1	14.5	-	-	-		
2GP(.) MATRIX 10-6/2.2	2.2+2.2	3.0+3.0	72.0		-	-	-	66.5	64.5	62.0	57.0	51.0	38.5	17.4	-	-	-		
2GP(.) MATRIX 18-3/2.2	2.2+2.2	3.0+3.0	36.3		-	-	-	-	-	-	33.0	31.9	30.4	28.1	25.2	21.3	15.5	7.8	
2GP(.) MATRIX 18-4/3	3.0+3.0	4.0+4.0	48.5		-	-	-	-	-	-	44.0	42.5	40.5	37.4	33.6	28.4	20.6	10.4	
2GP(.) MATRIX 18-5/4	4+4	5.5+5.5	60.5		-	-	-	-	-	-	55.0	53.0	50.5	47.0	42.0	35.5	25.8	13.0	
2GP(.) MATRIX 18-6/4	4+4	5.5+5.5	72.5		-	-	-	-	-	-	66.0	64.0	60.5	56.0	50.5	42.5	30.9	15.8	

PERFORMANCE CURVE 2GP(.) 2GP(.) MATRIX 3-4T/0.65

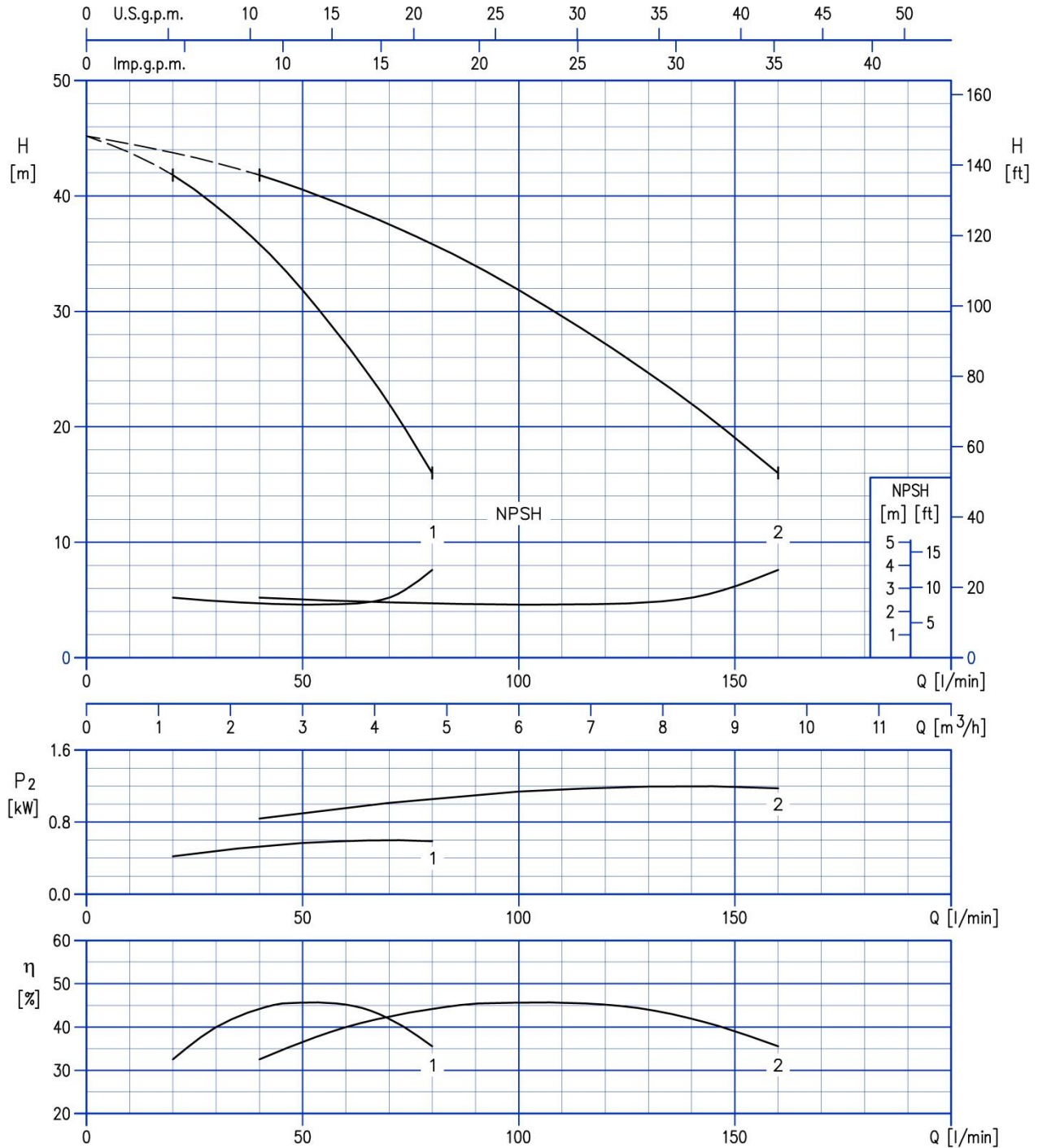

Test standard: ISO 9906: 2012 - Grade 3B

2GP(.) MATRIX 3-5T/0.75

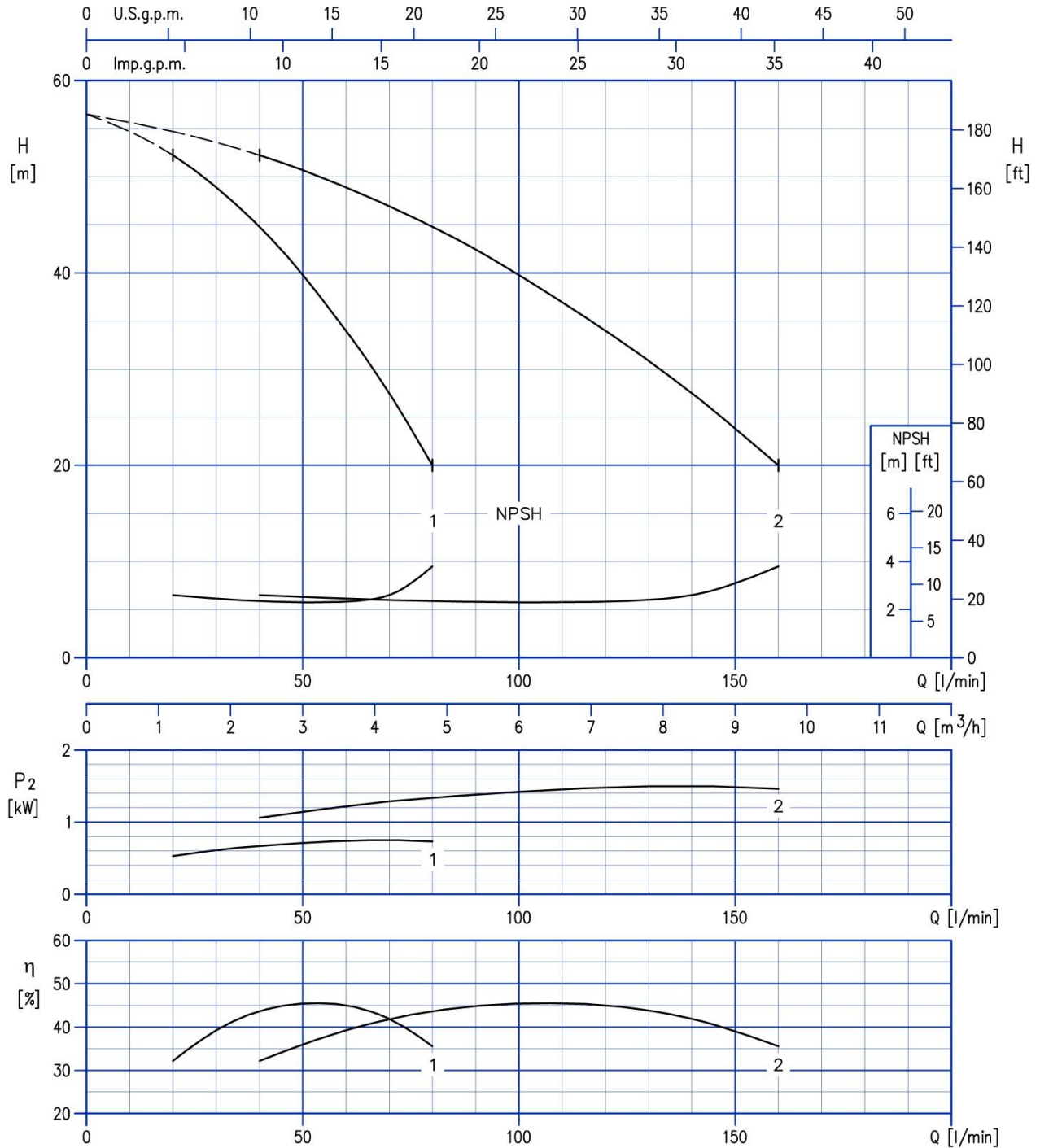

Test standard: ISO 9906: 2012 - Grade 3B

2GP(.) MATRIX 3-6T/0.9

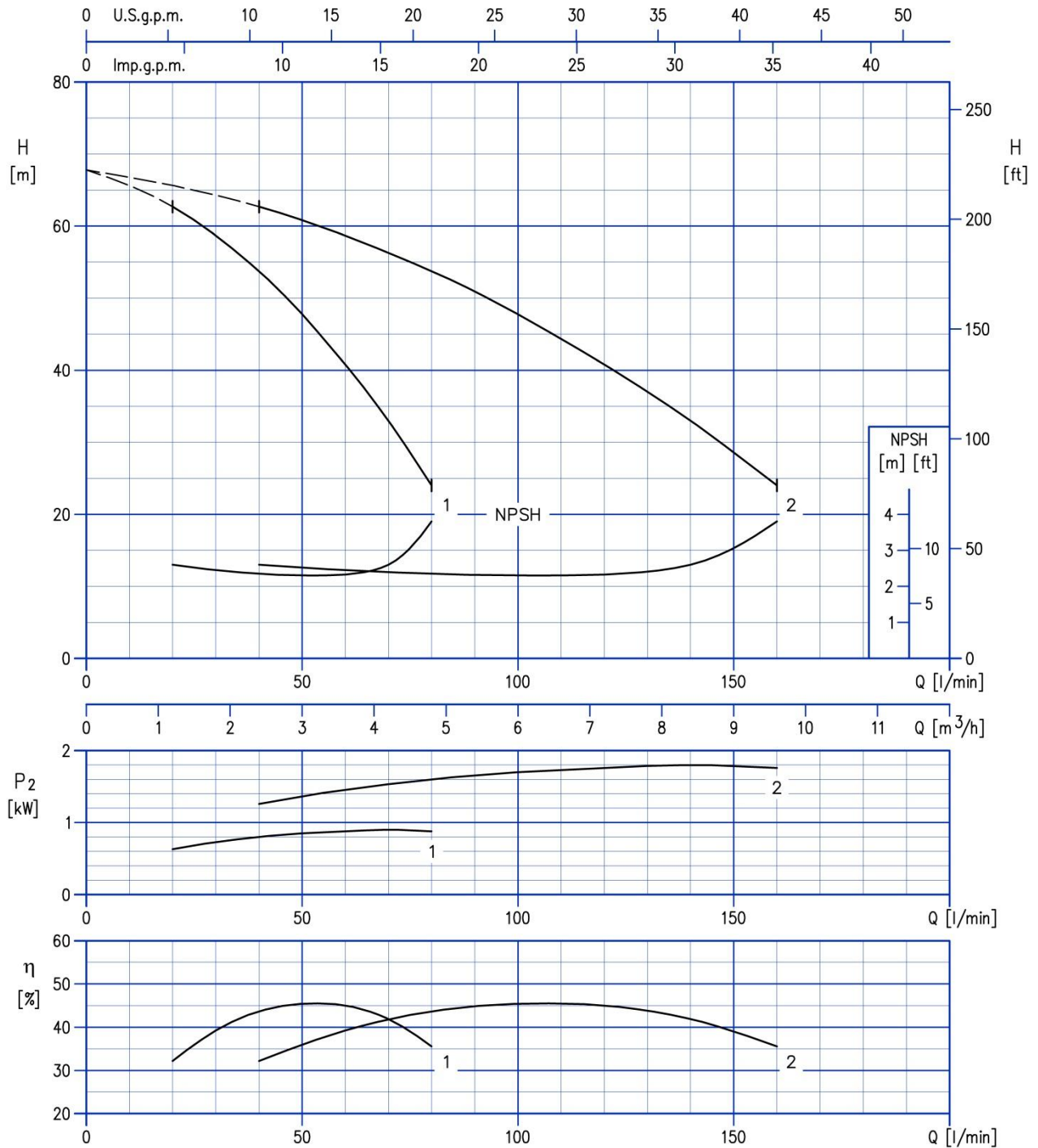

Test standard: ISO 9906: 2012 - Grade 3B

405

2GP(.) MATRIX 3-7T/1.3

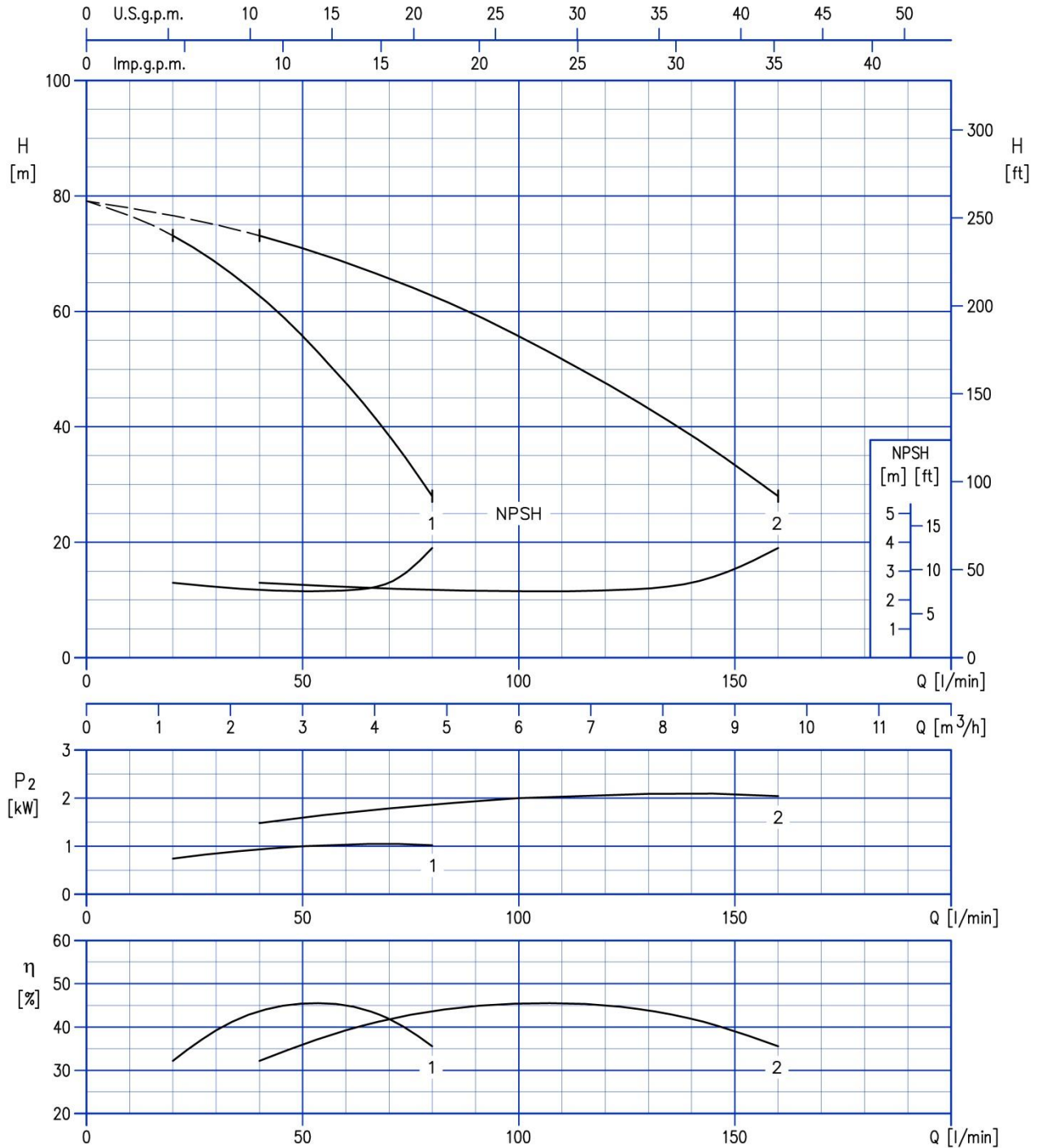

Test standard: ISO 9906: 2012 - Grade 3B

2GP(.) MATRIX 3-8T/1.3

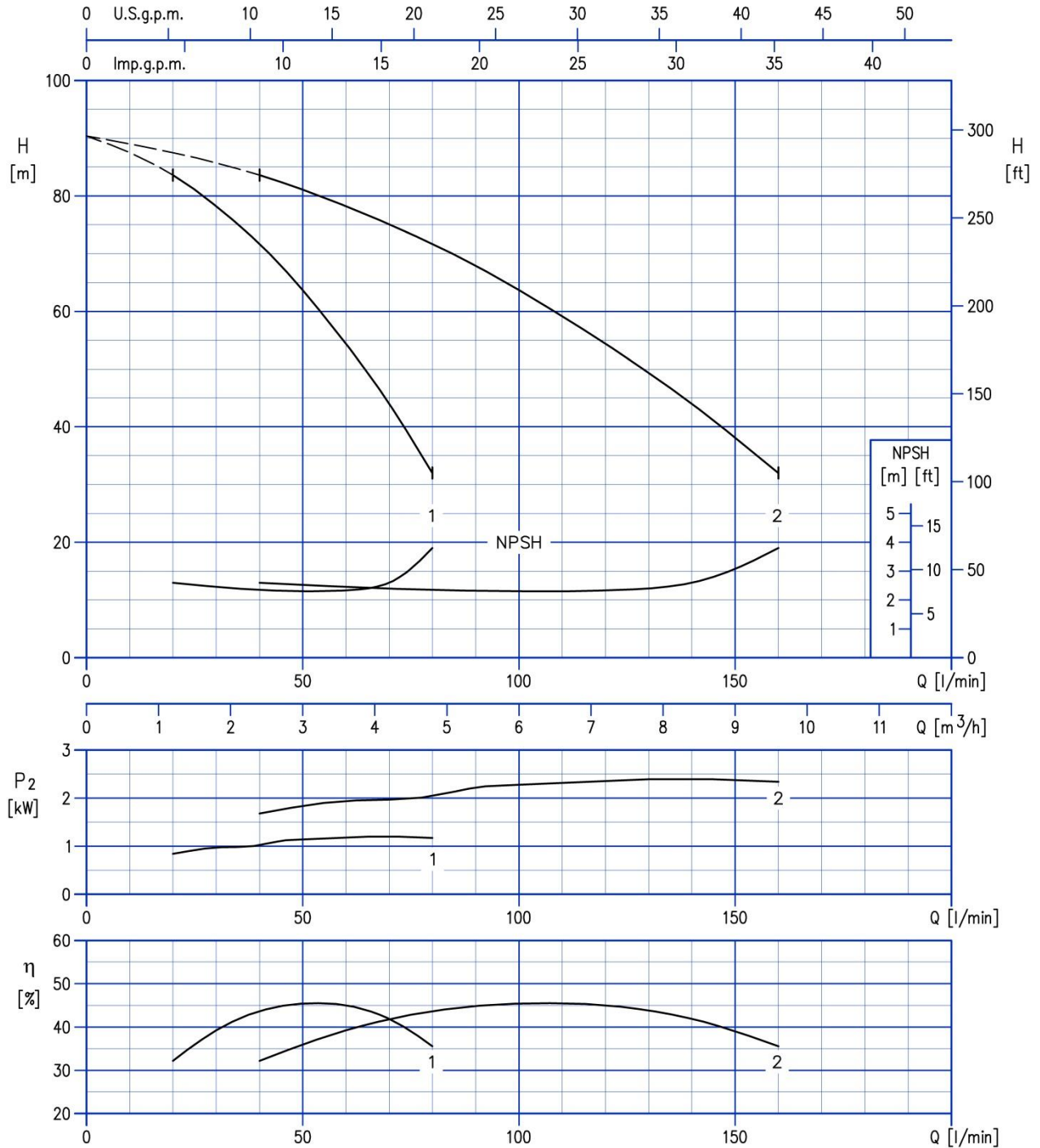

Test standard: ISO 9906: 2012 - Grade 3B

2GP(.) MATRIX 3-9T/1.5

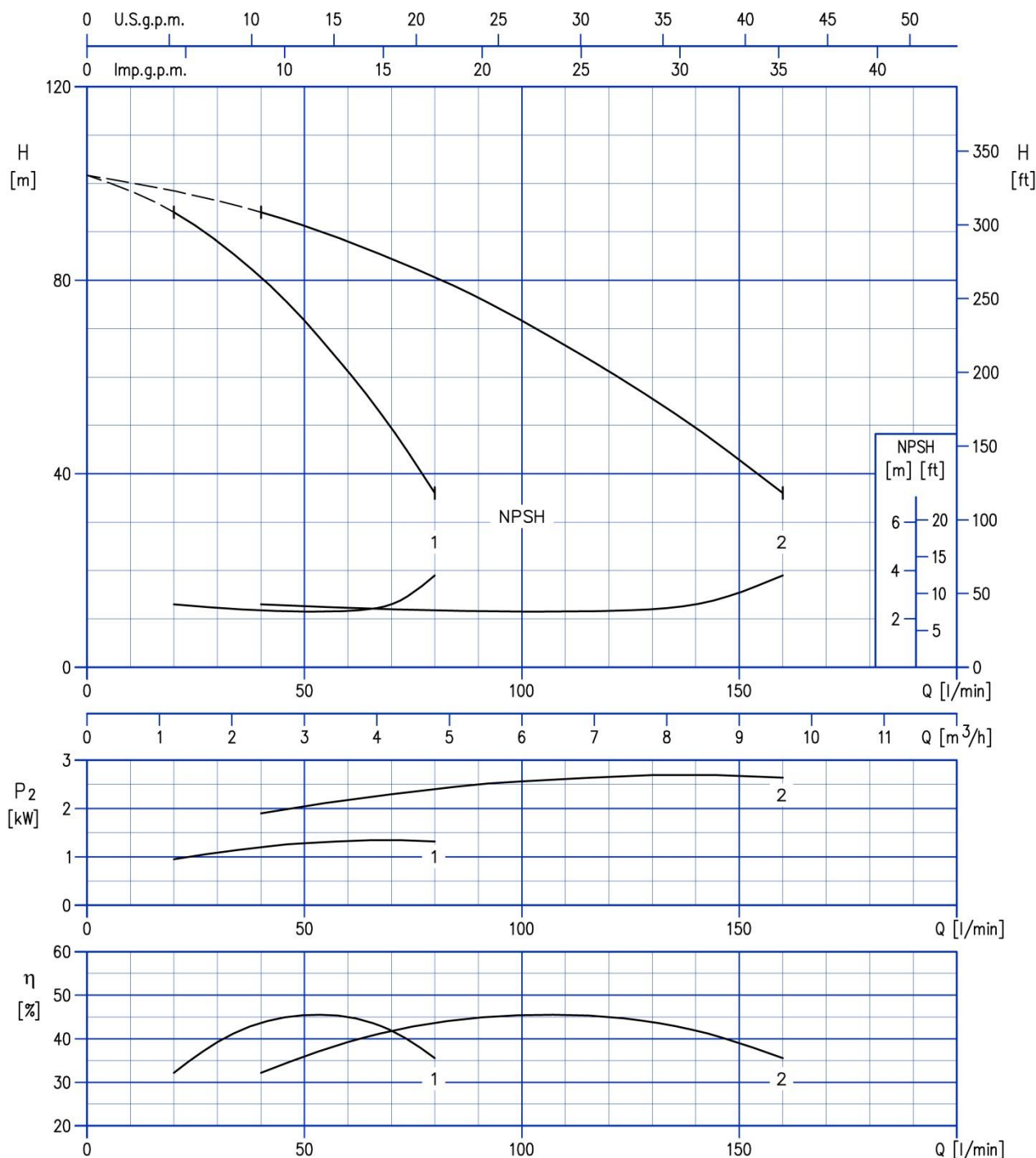

Test standard: ISO 9906: 2012 - Grade 3B

2GP(.) MATRIX 5-3T/0.65

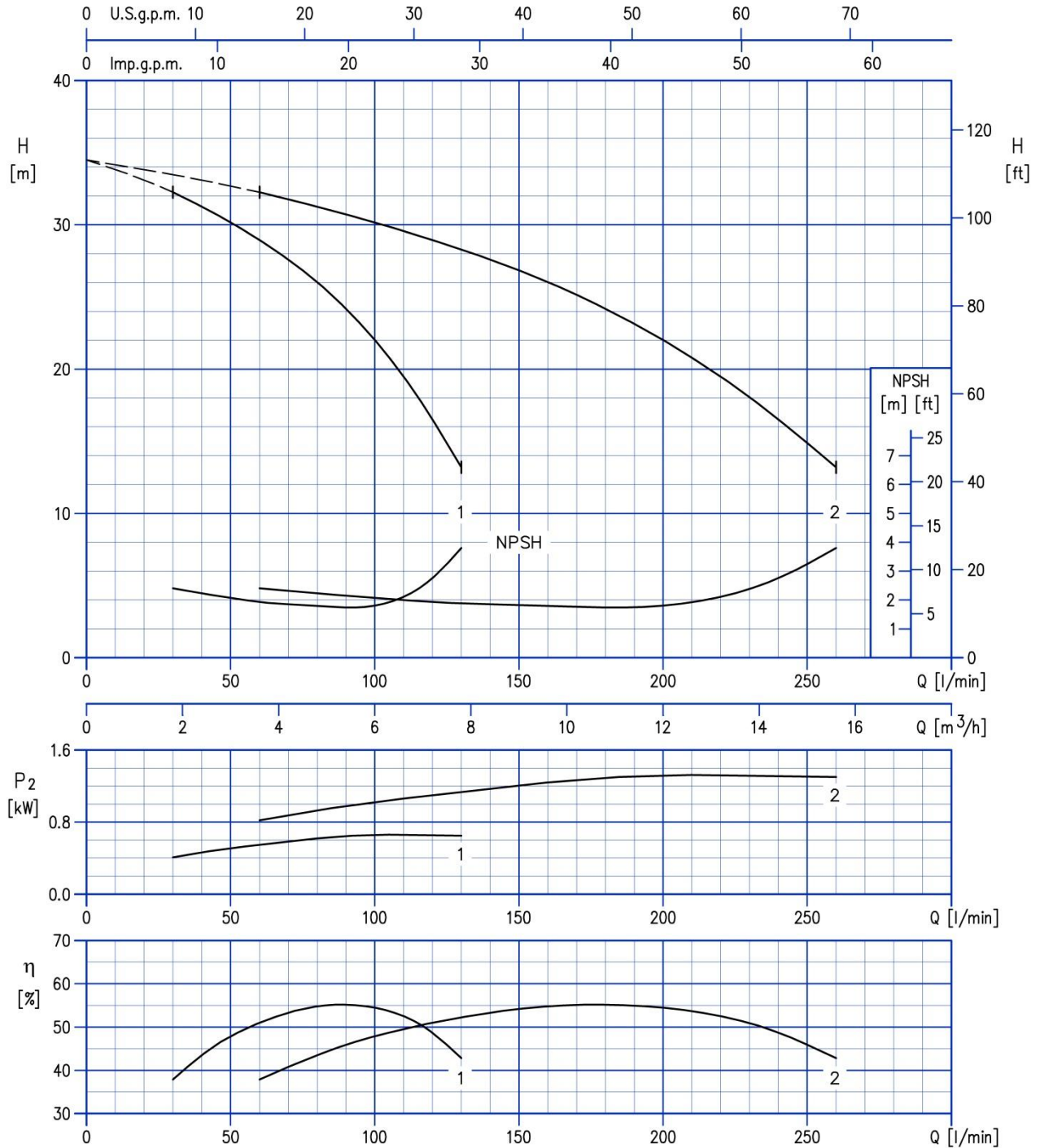

Test standard: ISO 9906: 2012 - Grade 3B

2GP(.) MATRIX 5-4T/0.9

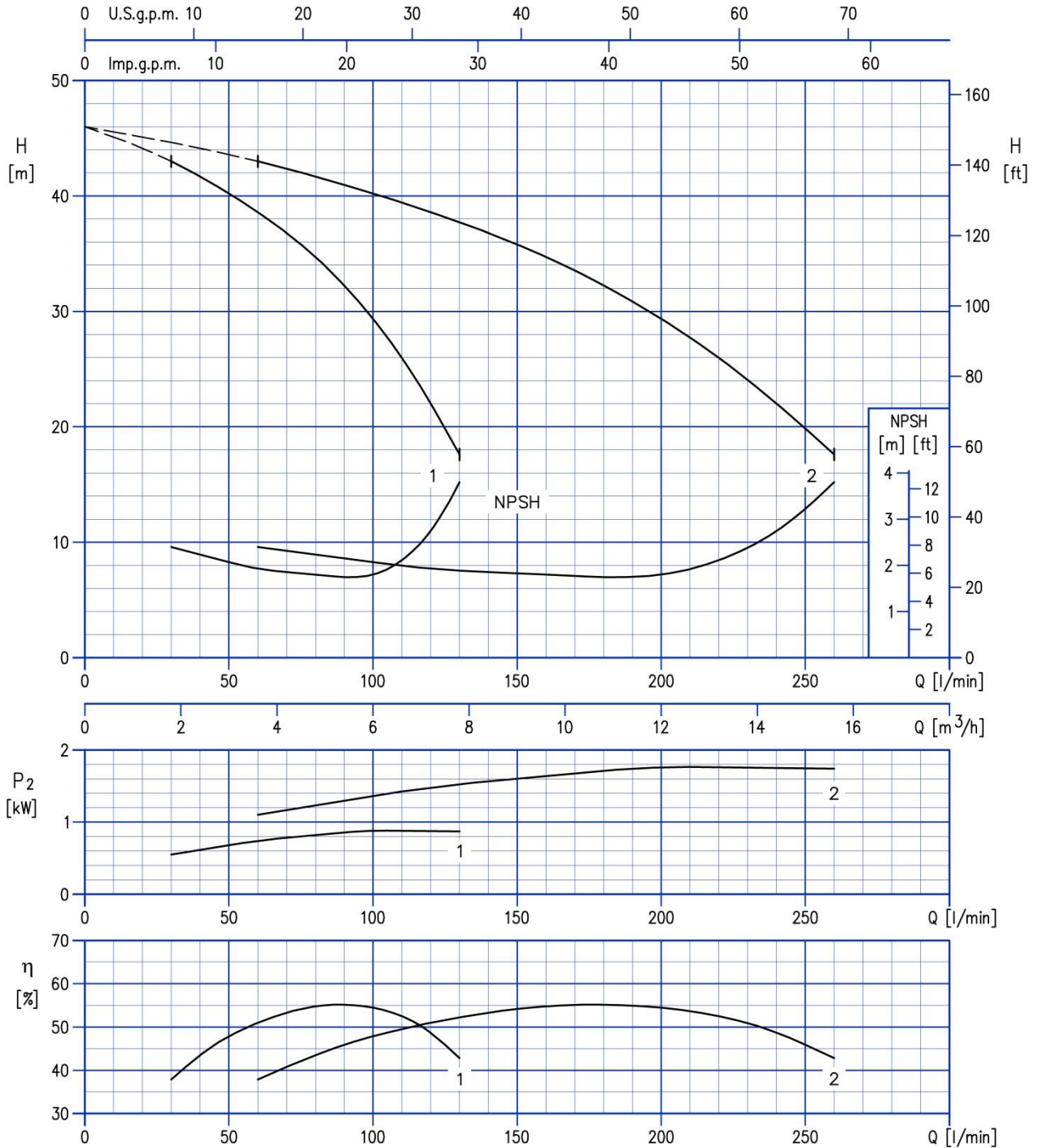

Test standard: ISO 9906: 2012 - Grade 3B

2GP(.) MATRIX 5-5T/1.3

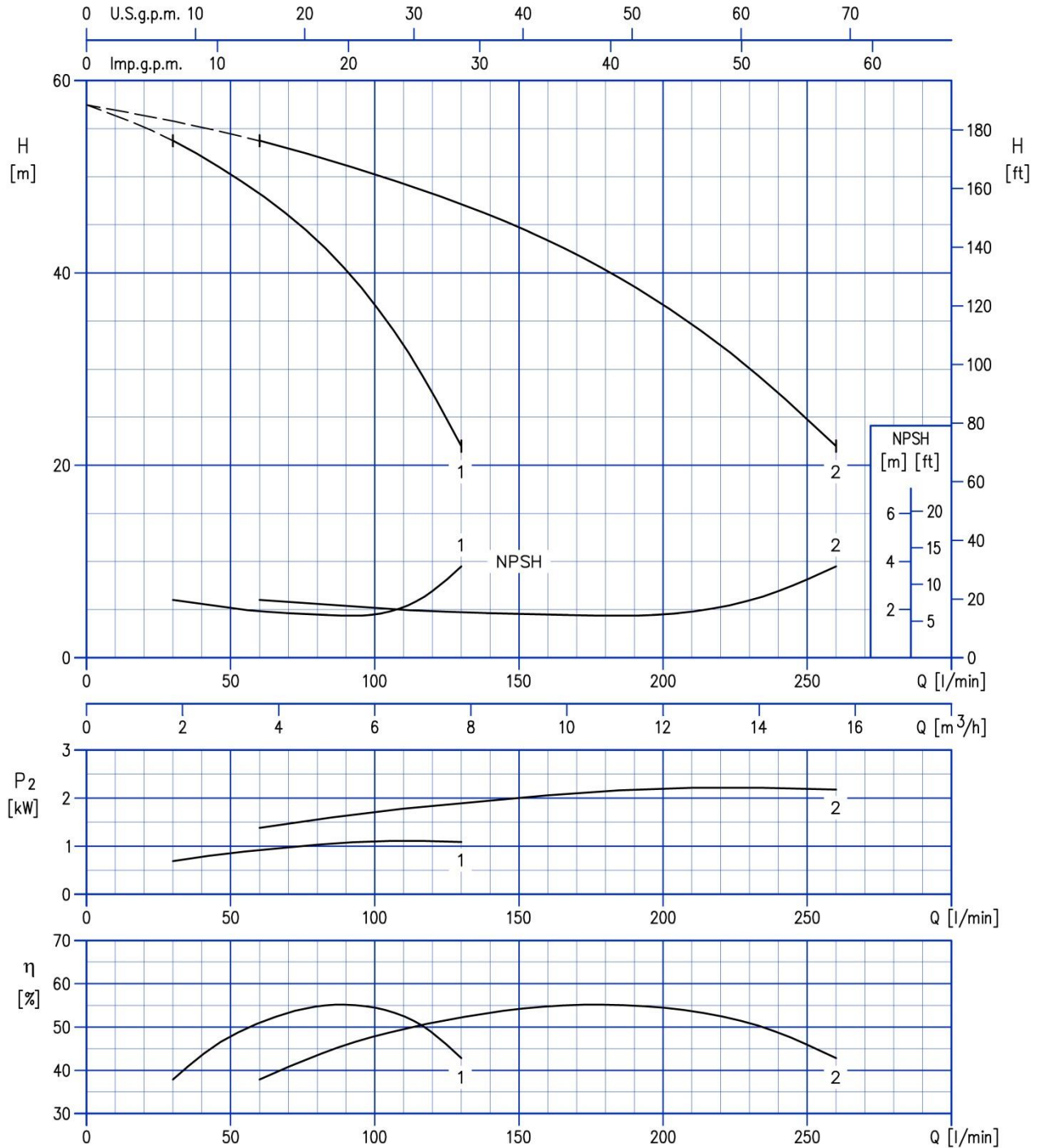

Test standard: ISO 9906: 2012 - Grade 3B

2GP(.) MATRIX 5-6T/1.3

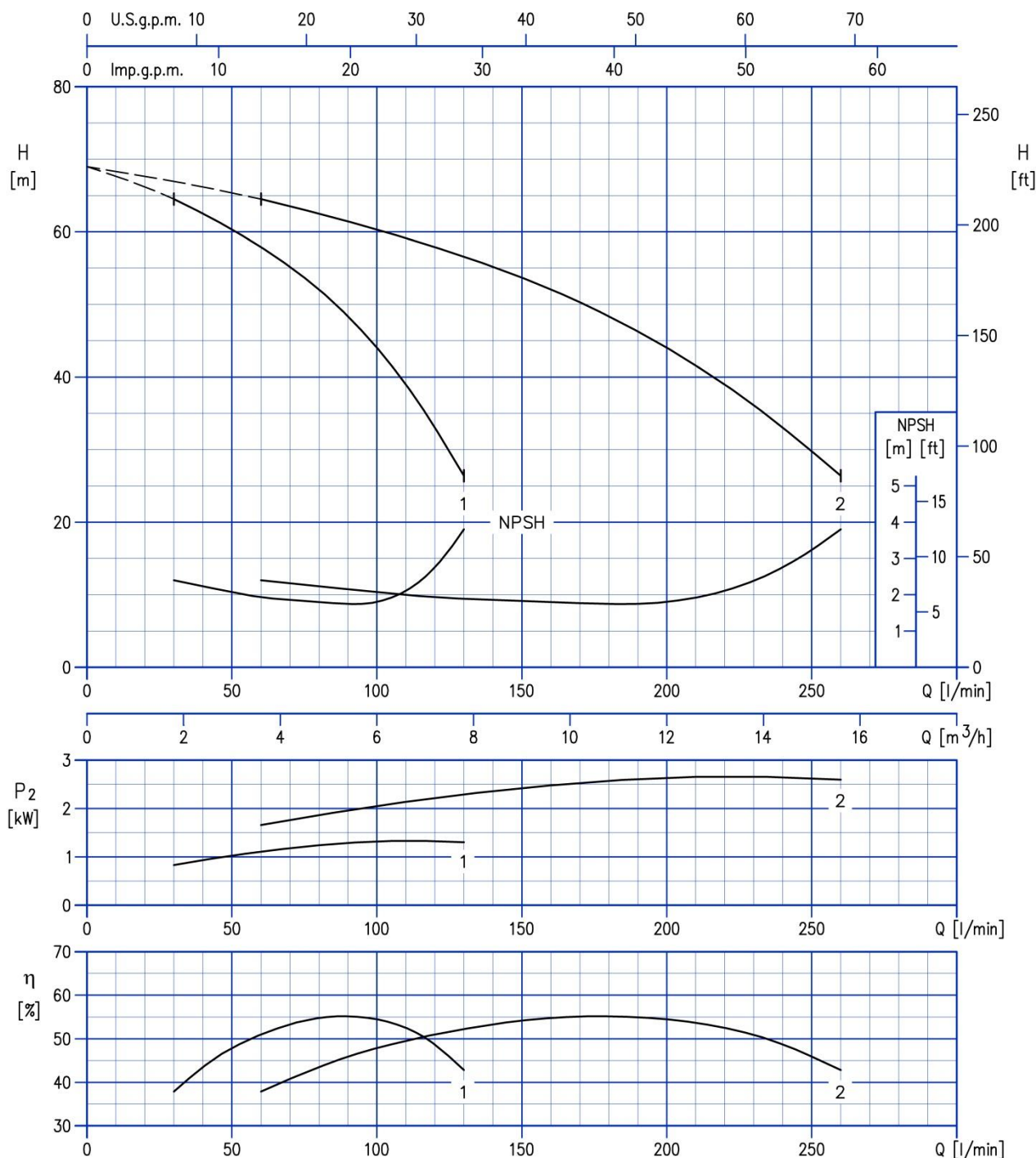

Test standard: ISO 9906: 2012 - Grade 3B

2GP(.) MATRIX 5-7T/1.5

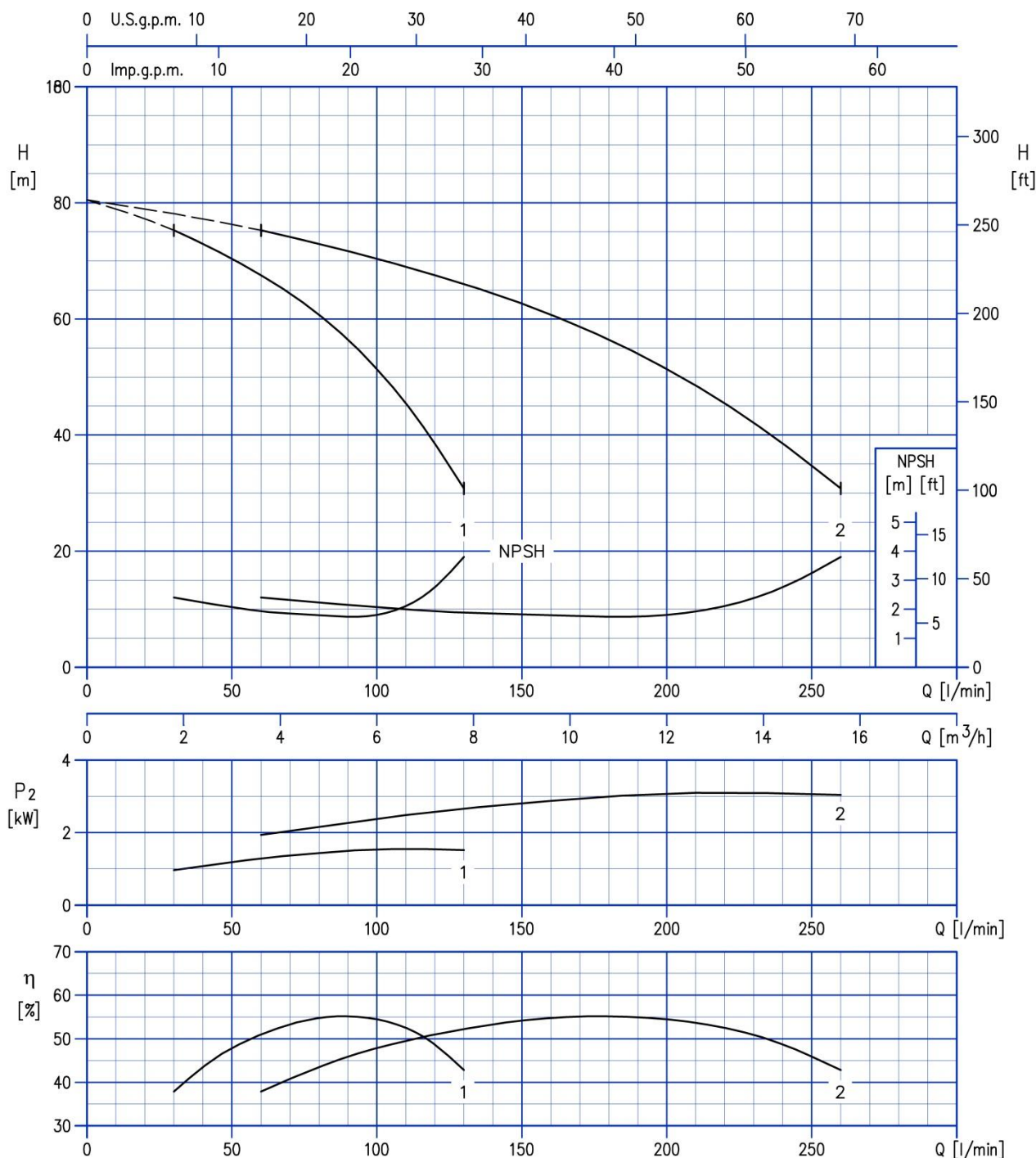

Test standard: ISO 9906: 2012 - Grade 3B

2GP(.) MATRIX 5-8T/2.2

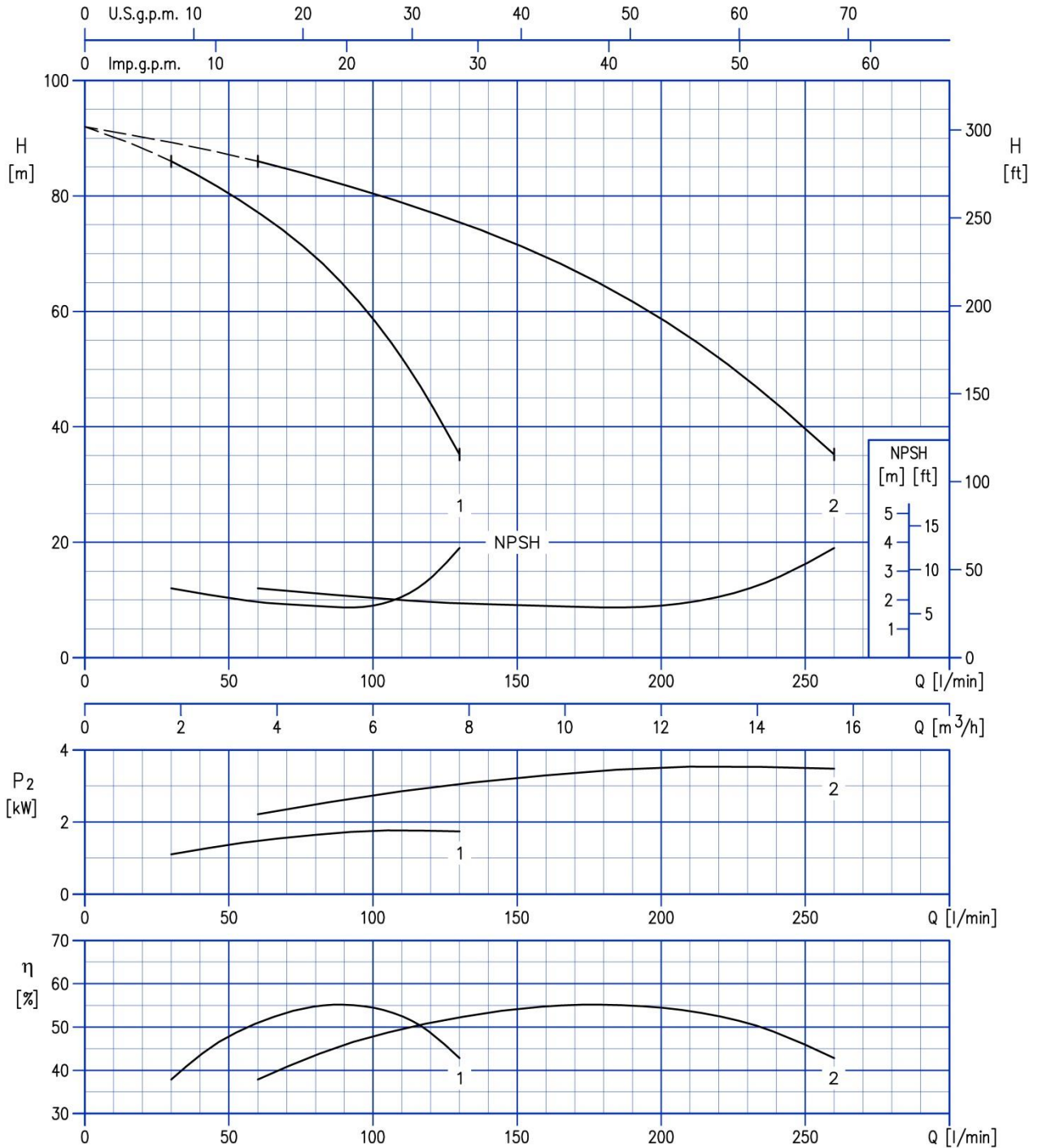

Test standard: ISO 9906: 2012 - Grade 3B

2GP(.) MATRIX 5-9T/2.2

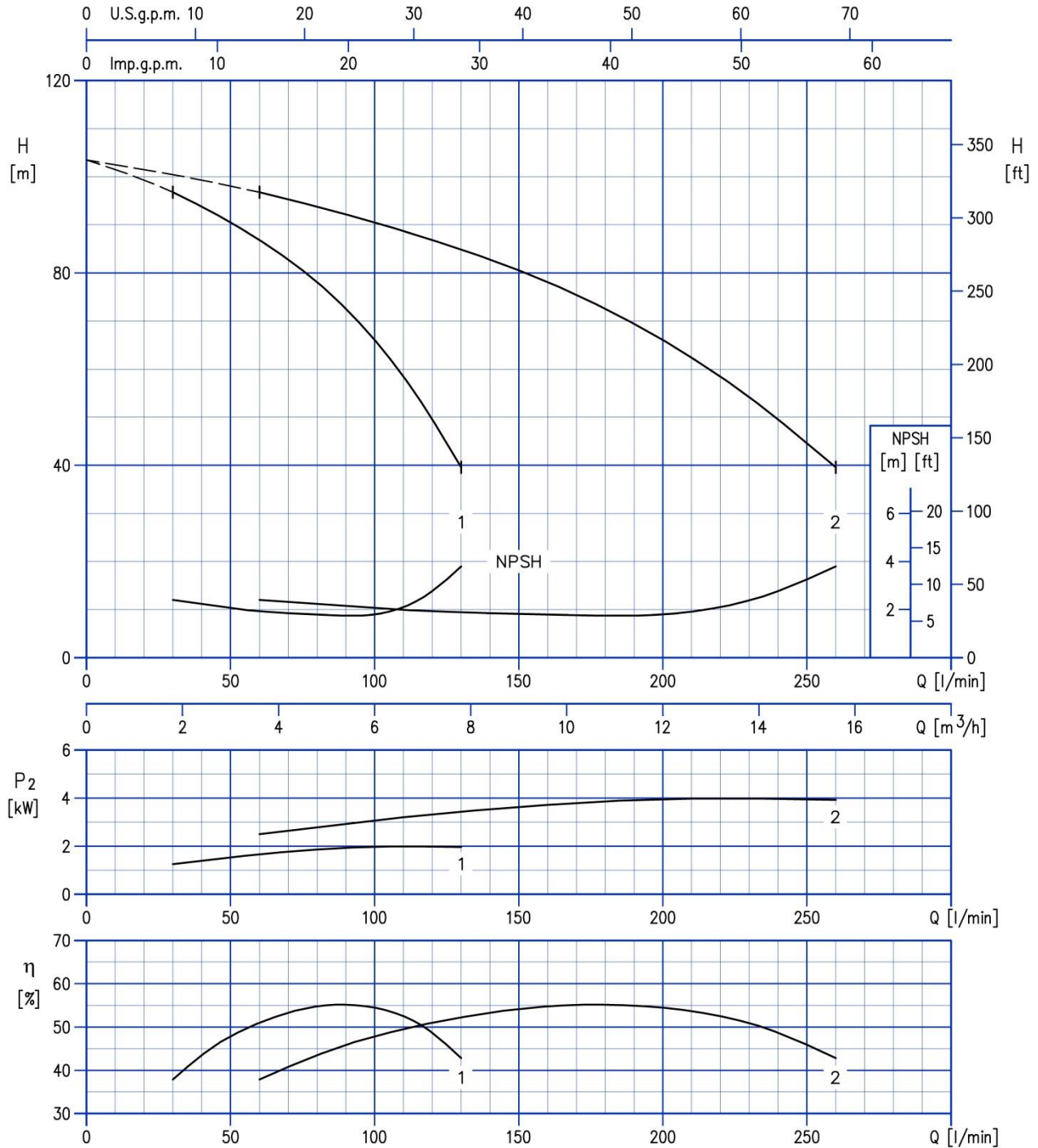

Test standard: ISO 9906: 2012 - Grade 3B

2GP(.) MATRIX 10-3T/1.3

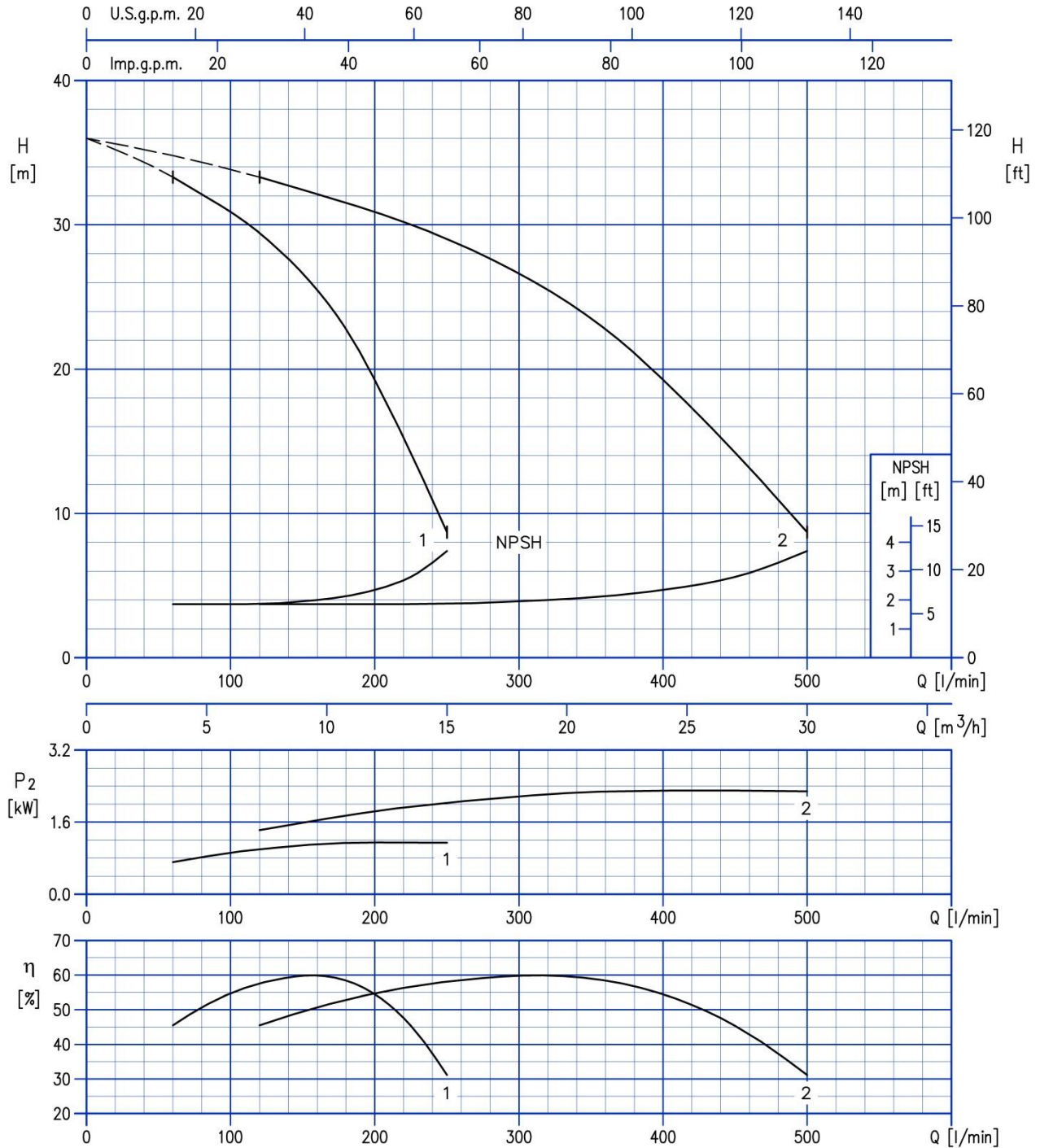

Test standard: ISO 9906: 2012 - Grade 3B

2GP(.) MATRIX 10-4T/1.5

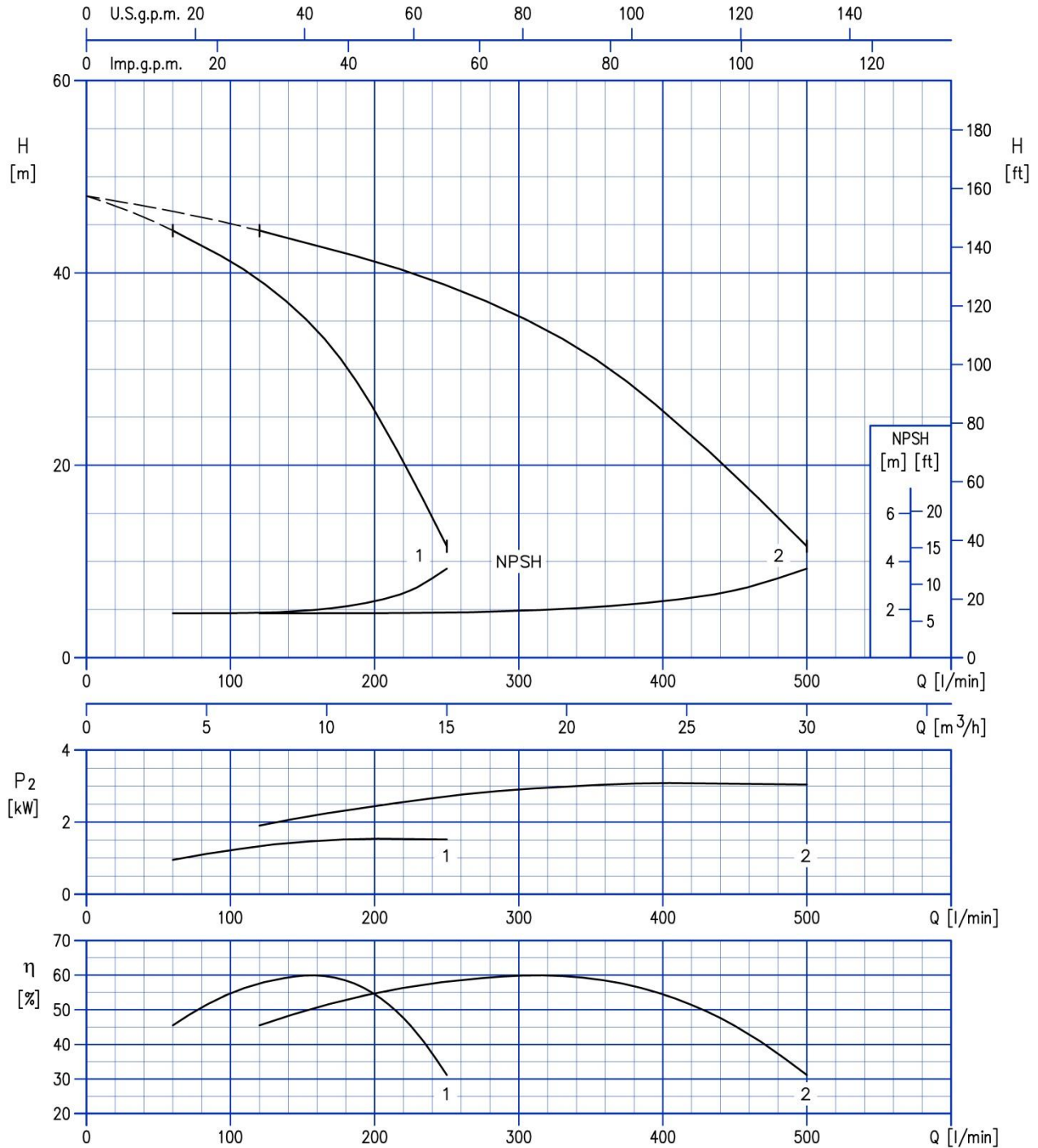

Test standard: ISO 9906: 2012 - Grade 3B

2GP(.) MATRIX 10-5T/2.2

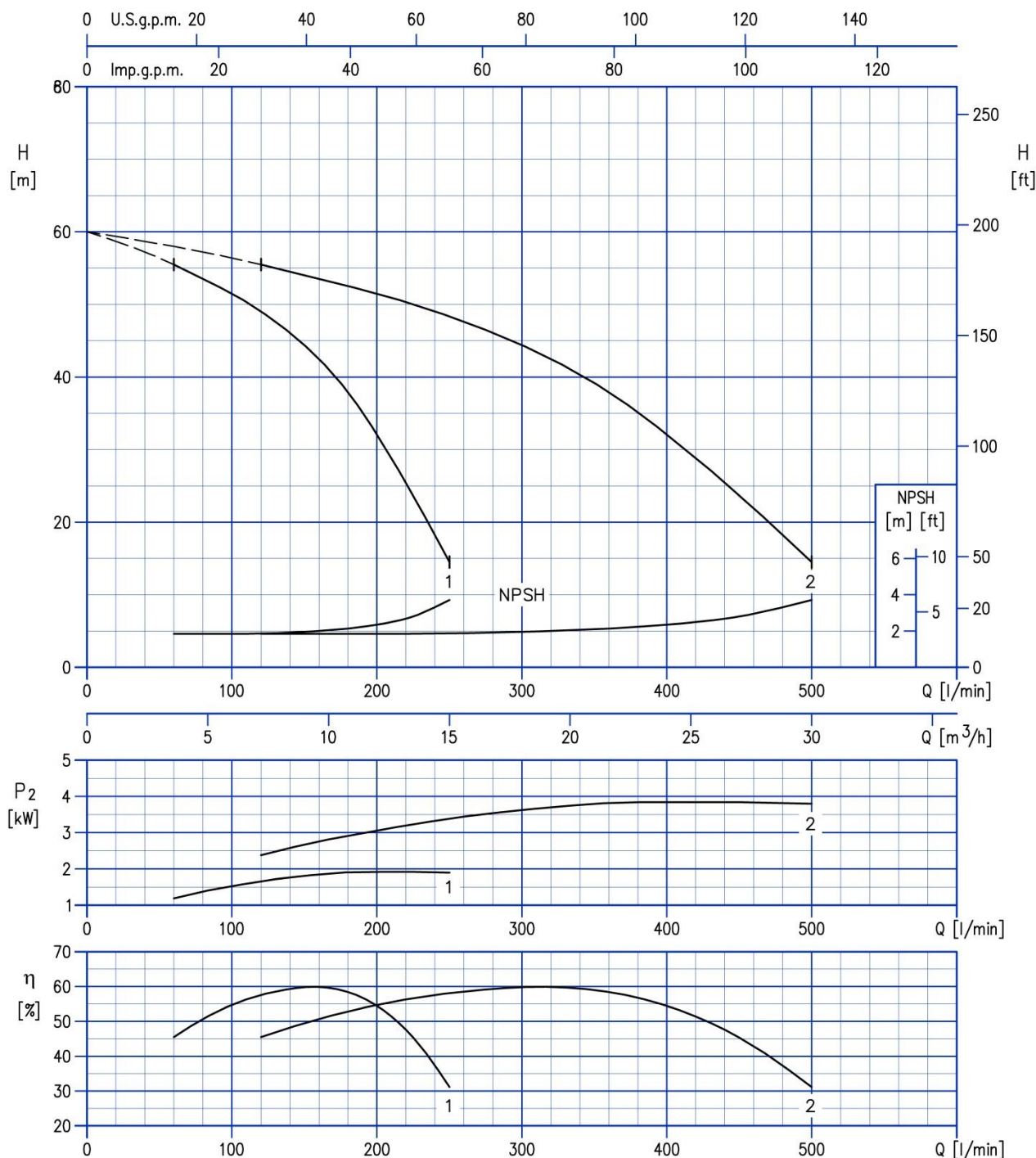

Test standard: ISO 9906: 2012 - Grade 3B

2GP(.) MATRIX 10-6T/2.2

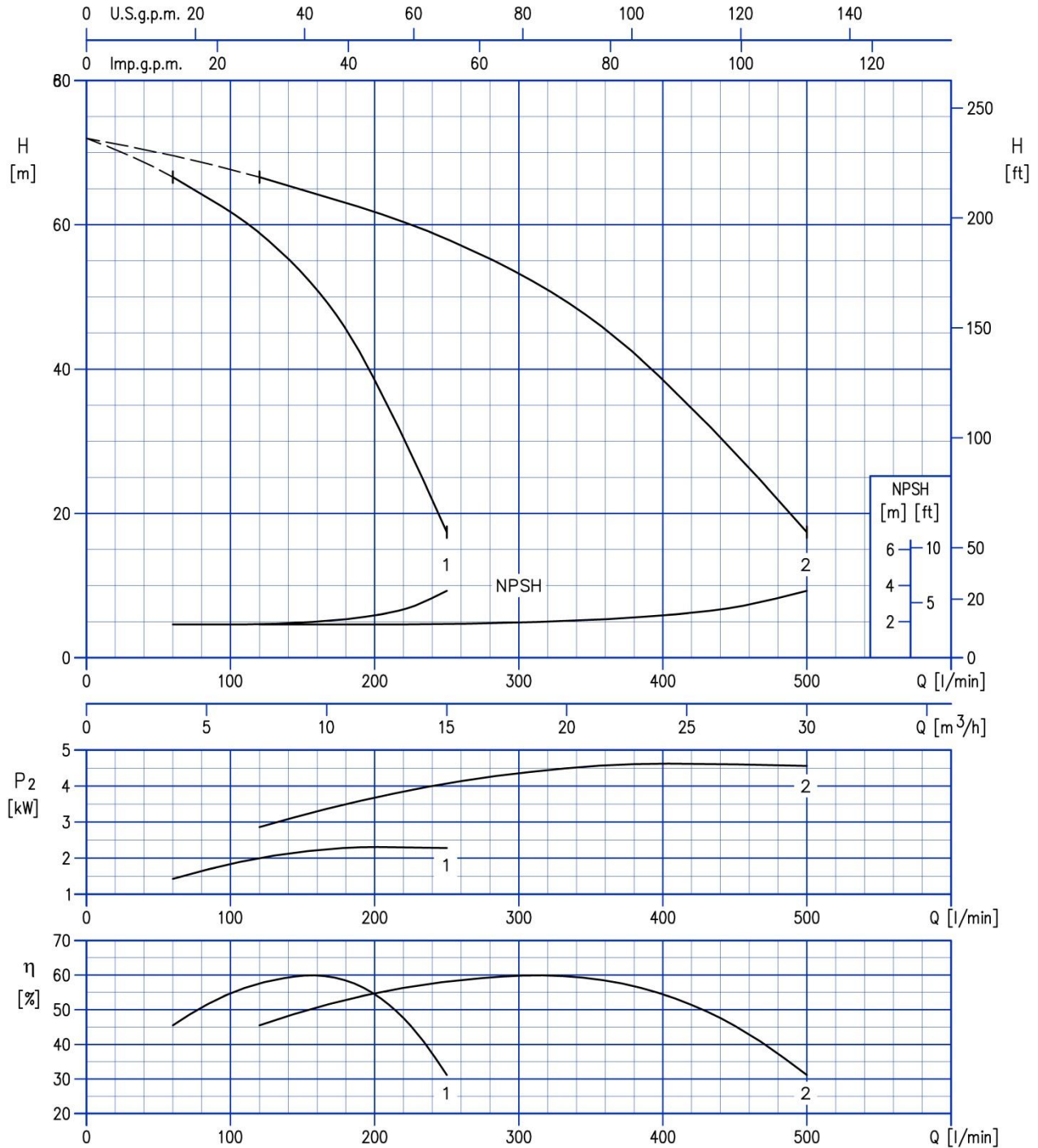

Test standard: ISO 9906: 2012 - Grade 3B

2GP(.) MATRIX 18-3T/2.2

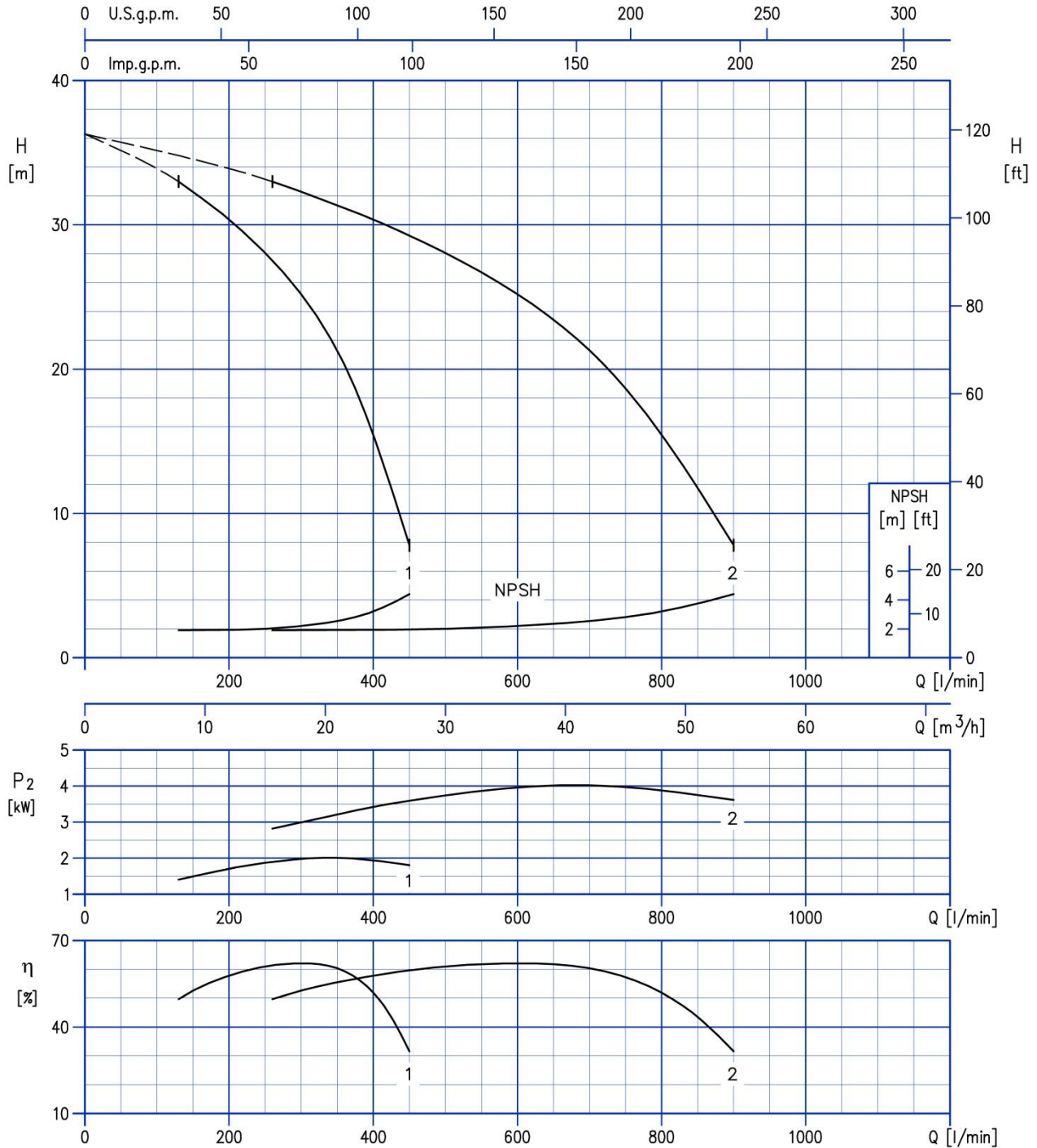

Test standard: ISO 9906: 2012 - Grade 3B

420

2GP(.) MATRIX 18-4T/3

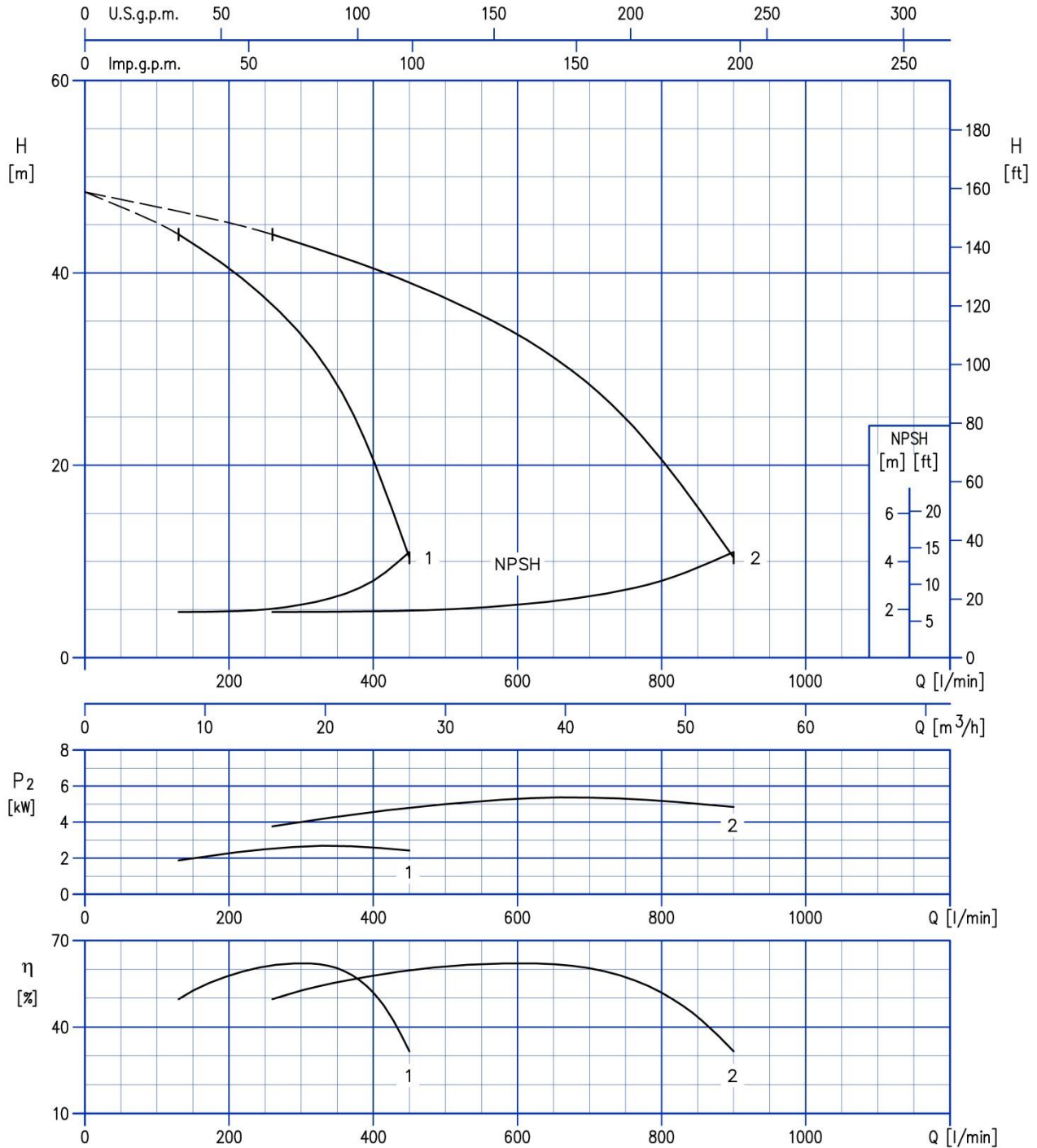

Test standard: ISO 9906: 2012 - Grade 3B

421

2GP(.) MATRIX 18-5T/4

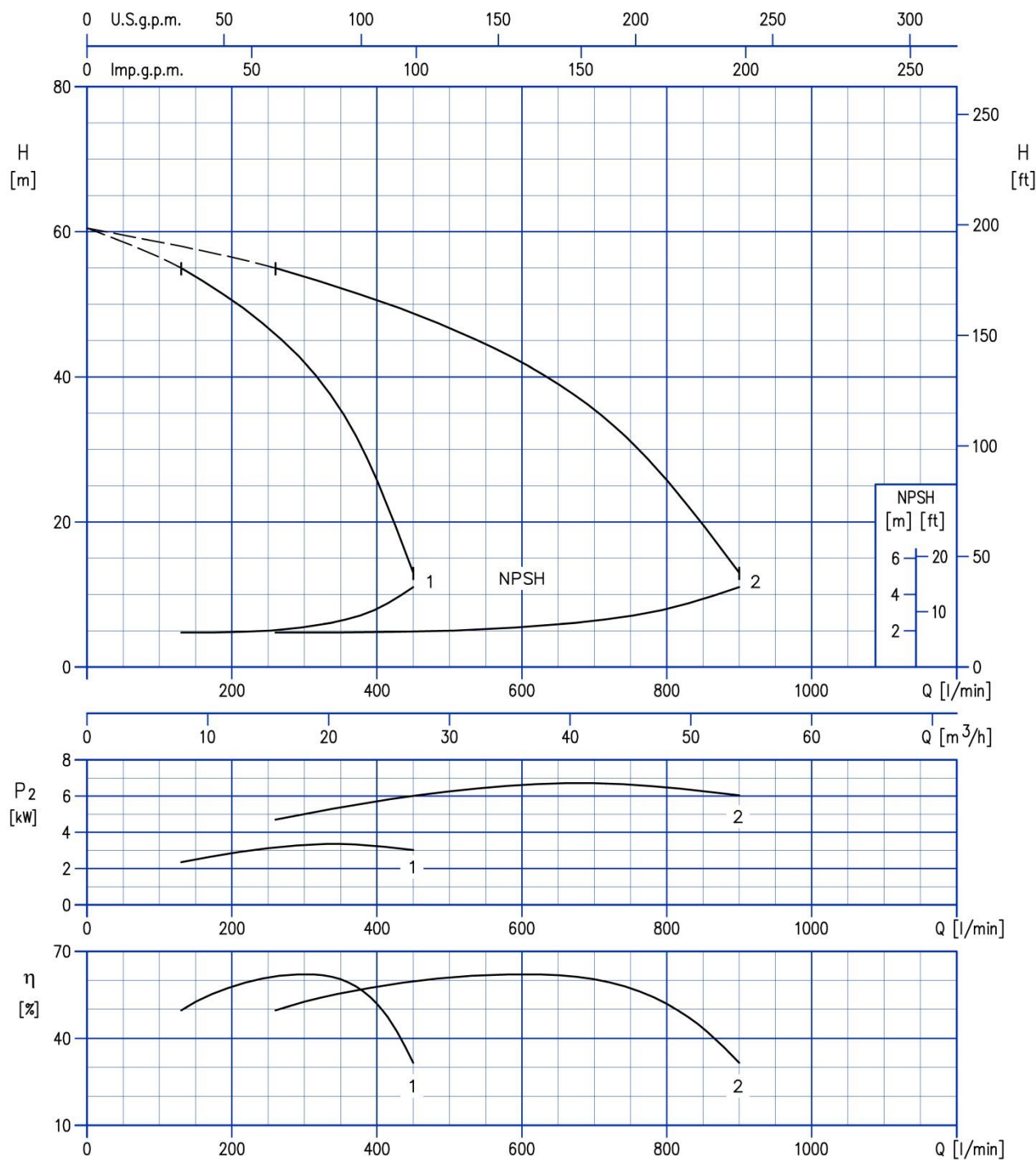

Test standard: ISO 9906: 2012 - Grade 3B

2GP(.) MATRIX 18-6T/4

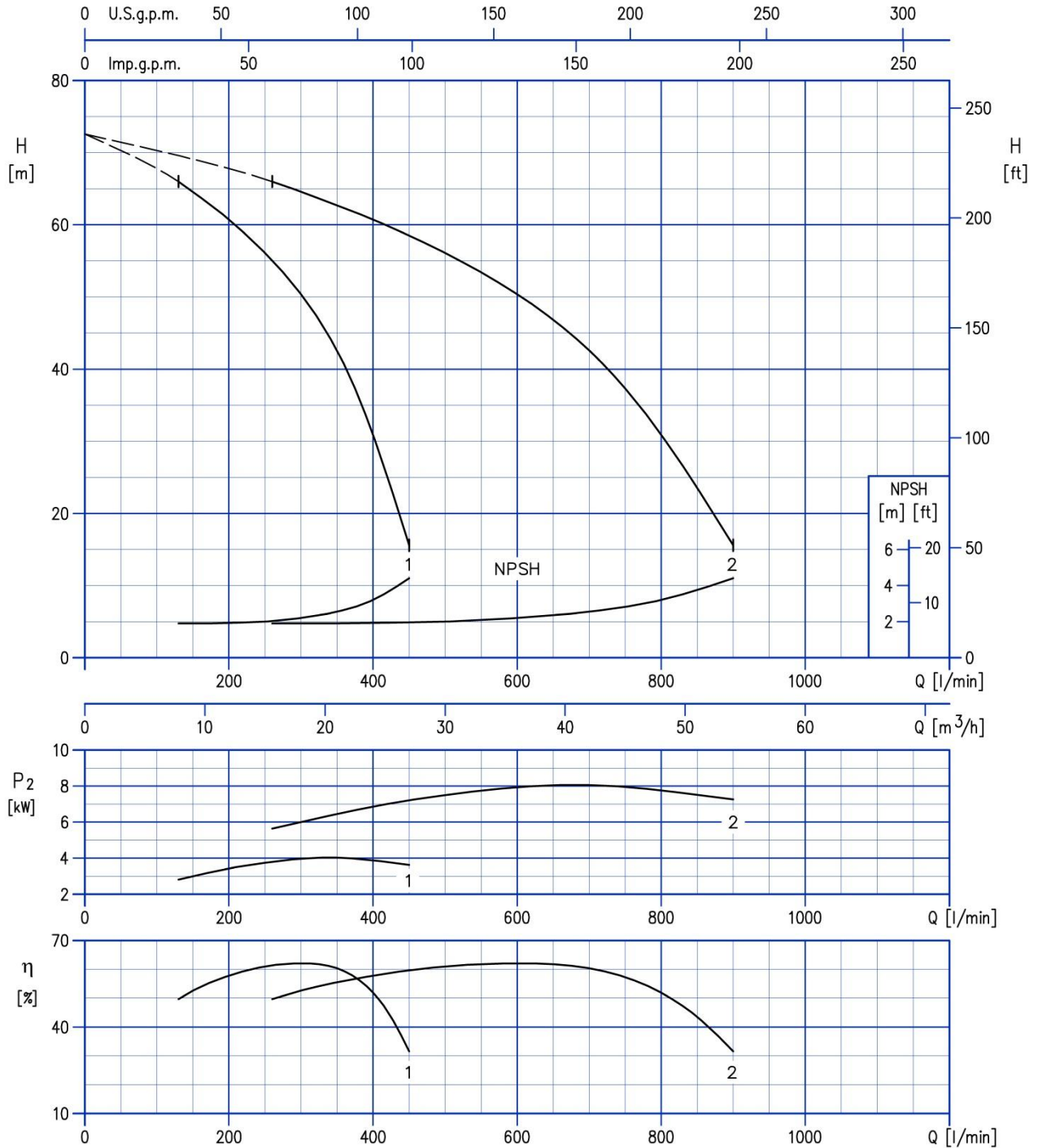

Test standard: ISO 9906: 2012 - Grade 3B

2GP CONSTRUCTION EXTERNAL VIEW 2GP MATRIX

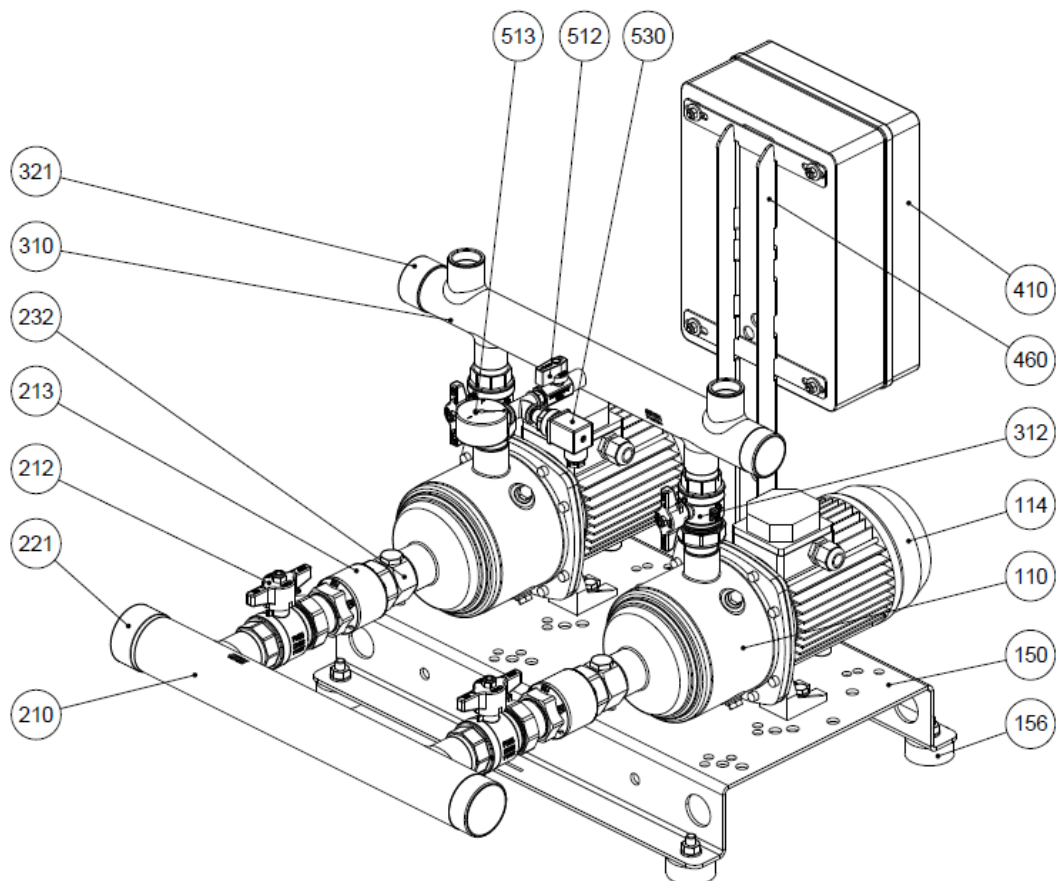

N°	PART NAME	MATERIAL	Quantity
110	Principal pump	-	2
114	Electric motor	-	2
150	Basement	Galvanized steel	1
156	Basement foot	SBR	4
210	Suction manifold	AISI 304	1
212	Union ball valve	Brass / P.T.F.E.	2
213	Check valve	Brass / NBR	2
221	Threaded female cap	AISI 304	1
232	Nipple for air feeders	Yellow brass	2
310	Discharge manifold	AISI 304	1
312	Union ball valve	Brass / P.T.F.E.	2
321	Threaded female cap	AISI 304	1
410	Control panel	-	1
460	Control panel frame	Galvanized steel	1
512	Ball valve	Brass / P.T.F.E.	1
513	Pressure gauge	Copper alloy / plastic	1
530	Pressure transmitter	-	1

601

EXTERNAL VIEW 2GPE MATRIX E-SPD+

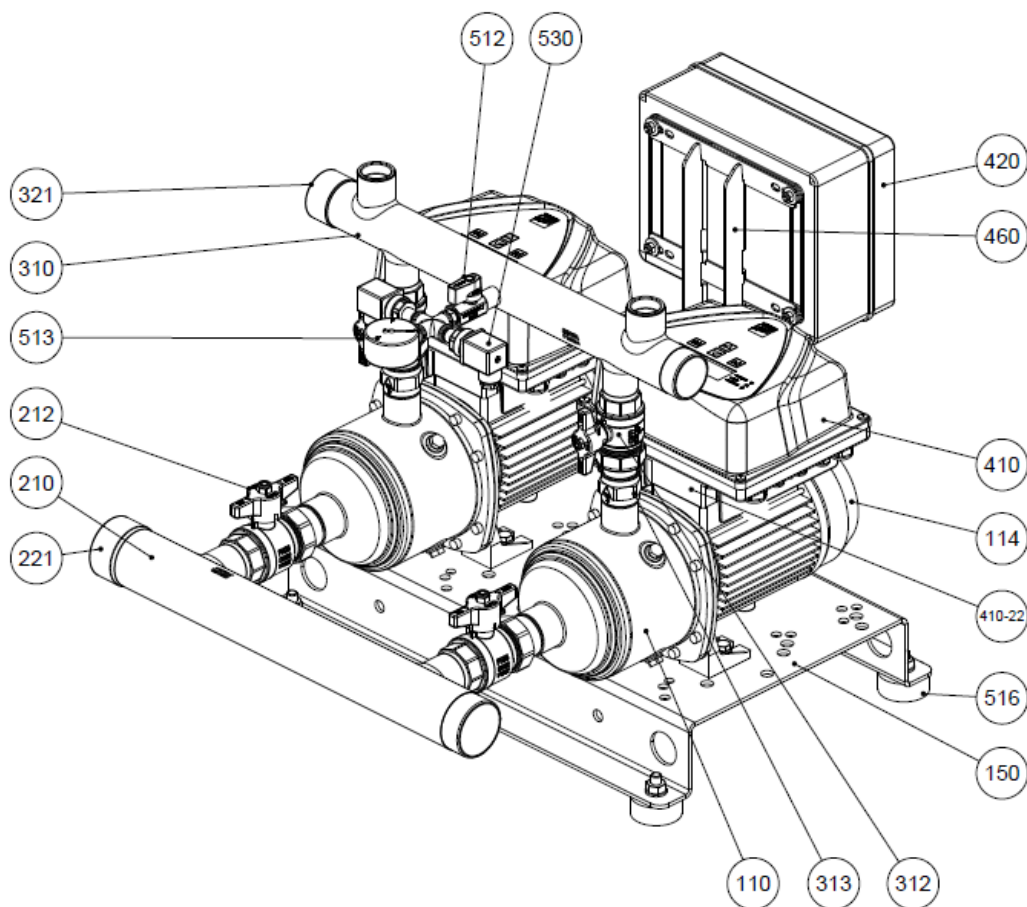

N°	PART NAME	MATERIAL	Quantity
110	Principal pump	-	2
114	Electric motor	-	2
150	Baseplate	Galvanized steel	1
156	Baseplate foot	SBR	4
210	Suction manifold	AISI 304	1
212	Union ball valve	Brass / P.T.F.E.	2
221	Threaded female cap	AISI 304	1
310	Discharge manifold	AISI 304	1
312	Union ball valve	Brass / P.T.F.E.	2
313	Check valve	Brass / NBR	2
321	Threaded female cap	AISI 304	1
410	E-SPD+	-	2
410-22	E-SPD+ adaptor	-	2
420	Protection panel	-	1
460	Protection panel frame	Galvanized steel	1
512	Ball valve	Brass / P.T.F.E.	1
513	Pressure gauge	Copper alloy / plastic	1
530	Pressure transmitter	-	2

OVERALL DIMENSIONS 2GP BOOSTER SET

2GP MATRIX

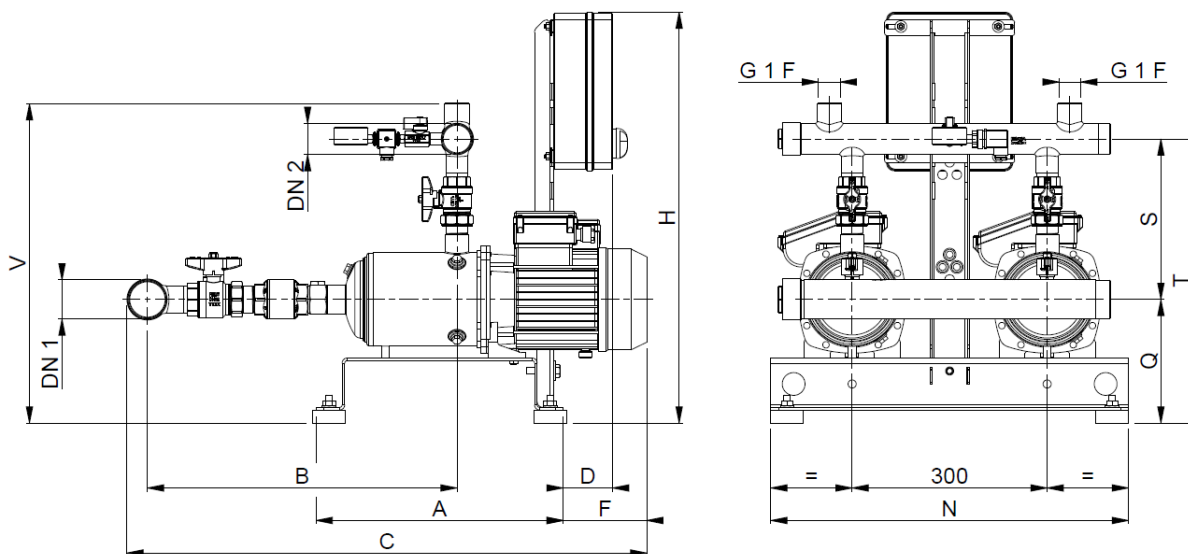

Booster Type	Dimensions [mm]																Weight [kg]				
	DN1	DN2	1~	3~	B	1~	3~	1~	3~	1~	3~	1~	3~	1~	3~	Q	S	T	V	1~	3~
2GP MATRIX 3-4T/0.65(M)	G1 1/2	G1 1/2	380	380	375	655	670	95	95	75	105	630	635	550	550	190	245	435	490	52	53
2GP MATRIX 3-5T/0.75(M)	G1 1/2	G1 1/2	380	380	400	680	690	95	95	75	105	630	635	550	550	190	245	435	490	55	57
2GP MATRIX 3-6T/0.9(M)	G1 1/2	G1 1/2	380	380	420	705	715	95	105	75	105	630	635	550	550	190	245	435	490	58	60
2GP MATRIX 3-7T/1.3(M)	G1 1/2	G1 1/2	380	540	445	765	895	130	5	75	105	630	635	550	570	190	245	435	490	63	74
2GP MATRIX 3-8T/1.3(M)	G1 1/2	G1 1/2	380	540	470	785	920	130	5	75	105	630	635	550	570	190	245	435	490	63	76
2GP MATRIX 3-9T/1.5(M)	G1 1/2	G1 1/2	380	540	495	810	940	130	5	75	105	630	635	550	570	190	245	435	490	67	80
2GP MATRIX 5-4T/0.9(M)	G2	G1 1/2	380	380	405	755	785	10	25	75	105	630	635	550	550	190	245	435	490	57	59
2GP MATRIX 5-5T/1.3(M)	G2	G1 1/2	380	380	430	780	810	45	75	75	105	630	635	550	550	190	245	435	490	64	74
2GP MATRIX 5-6T/1.3(M)	G2	G1 1/2	380	380	455	805	835	45	75	75	105	630	635	550	550	190	245	435	490	63	74
2GP MATRIX 5-7T/1.5(M)	G2	G1 1/2	380	540	480	800	930	130	5	75	105	630	640	550	570	190	245	435	490	69	79
2GP MATRIX 5-8T/2.2(M)	G2	G1 1/2	540	540	505	955	955	25	5	105	105	640	640	570	570	190	245	435	490	82	79
2GP MATRIX 5-9T/2.2(M)	G2	G1 1/2	540	540	525	980	980	25	5	105	105	640	640	570	570	190	245	435	490	84	80
2GP MATRIX 10-3T/1.3(M)	G2 1/2	G2 1/2	380	380	440	775	800	130	155	75	105	630	635	550	550	190	270	460	530	66	74
2GP MATRIX 10-4T/1.5(M)	G2 1/2	G2 1/2	380	540	470	805	935	130	5	75	105	630	635	550	570	190	270	460	530	68	81
2GP MATRIX 10-5T/2.2(M)	G2 1/2	G2 1/2	540	540	485	965	965	25	5	105	105	640	640	570	570	190	270	460	530	86	83
2GP MATRIX 10-6T/2.2(M)	G2 1/2	G2 1/2	540	540	515	995	995	25	5	105	105	640	640	570	570	190	270	460	530	87	83
2GP MATRIX 18-3T/2.2(M)	G3	G3	540	540	540	1015	1015	25	-	105	105	640	640	570	570	190	305	495	565	94	91
2GP MATRIX 18-4T/3	G3	G3	-	540	575	-	1055	-	60	-	105	-	640	-	570	190	305	495	565	-	102
2GP MATRIX 18-5T/4	G3	G3	-	540	615	-	1090	-	75	-	105	-	640	-	570	200	305	505	575	-	121
2GP MATRIX 18-6T/4	G3	G3	-	540	650	-	1130	-	75	-	105	-	640	-	570	200	305	505	575	-	123

Approximate dimensions ± 20 mm.
The dimensions may change without notice.

603

2GPE MATRIX 3-5-10 E-SPD+

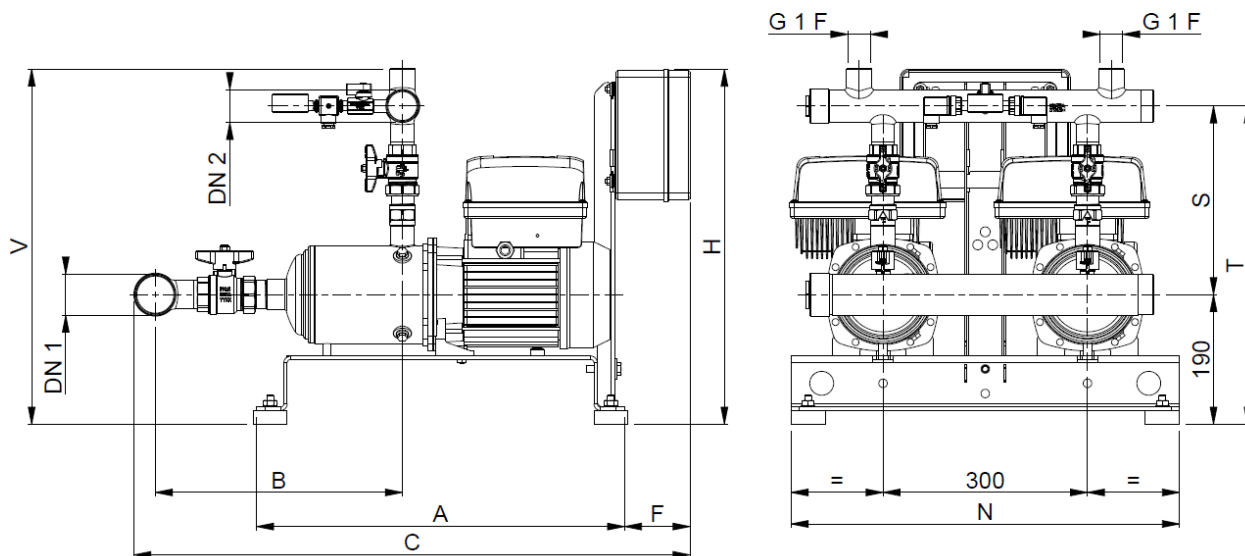

Booster Type	Dimensions [mm]												Weight [kg]			
	DN1	DN2	A	B	ESPM	ESPT	C	ESPM	ESPT	F	ESPM	ESPT		H	N	S
2GPE MATRIX 3-3T/0.65 ESPM	G1 1/2	G1 1/2	380	255	665	-	80	-	340	-	550	275	465	520	49	
2GPE MATRIX 3-4T/0.65 ESPT (ESPM)	G1 1/2	G1 1/2	380	275	690	705	80	95	340	520	550	275	465	520	50	
2GPE MATRIX 3-5T/0.75 ESPT (ESPM)	G1 1/2	G1 1/2	380	300	715	730	80	95	340	520	550	275	465	520	50	
2GPE MATRIX 3-6T/0.9 ESPT (ESPM)	G1 1/2	G1 1/2	380	320	735	755	80	95	340	520	550	275	465	520	52	
2GPE MATRIX 3-7T/1.3 ESPT (ESPM)	G1 1/2	G1 1/2	540	345	775	790	80	95	520	520	570	275	465	520	67	
2GPE MATRIX 3-8T/1.3 ESPT	G1 1/2	G1 1/2	540	370	-	815	-	95	-	520	570	275	465	520	69	
2GPE MATRIX 3-9T/1.5 ESPT	G1 1/2	G1 1/2	540	395	-	840	-	95	-	520	570	275	465	520	73	
2GPE MATRIX 5-3T/0.65 ESPM	G2	G1 1/2	380	265	685	-	80	-	520	-	550	275	465	520	46	
2GPE MATRIX 5-4T/0.9 ESPT (ESPM)	G2	G1 1/2	380	290	710	725	80	95	520	520	550	275	465	520	51	
2GPE MATRIX 5-5T/1.3 ESPT (ESPM)	G2	G1 1/2	540	315	750	770	80	95	520	520	570	275	465	520	66	
2GPE MATRIX 5-6T/1.3 ESPT (ESPM)	G2	G1 1/2	540	340	775	790	80	95	520	520	570	275	465	520	67	
2GPE MATRIX 5-7T/1.5 ESPT	G2	G1 1/2	540	365	-	815	-	95	-	520	570	275	465	520	72	
2GPE MATRIX 5-8T/2.2 ESPT	G2	G1 1/2	540	385	-	840	-	95	-	520	570	275	465	520	72	
2GPE MATRIX 5-9T/2.2 ESPT	G2	G1 1/2	540	410	-	865	-	95	-	520	570	275	465	520	72	
2GPE MATRIX 10-4T/1.5 ESPT	G2 1/2	G2 1/2	540	345	-	810	-	95	-	520	570	310	500	570	74	
2GPE MATRIX 10-5T/2.2 ESPT	G2 1/2	G2 1/2	540	375	-	840	-	95	-	520	570	310	500	570	75	
2GPE MATRIX 10-6T/2.2 ESPT	G2 1/2	G2 1/2	540	405	-	870	-	95	-	520	570	310	500	570	76	

Approximate dimensions ± 20mm.
The dimensions may change without notice.

PACKING

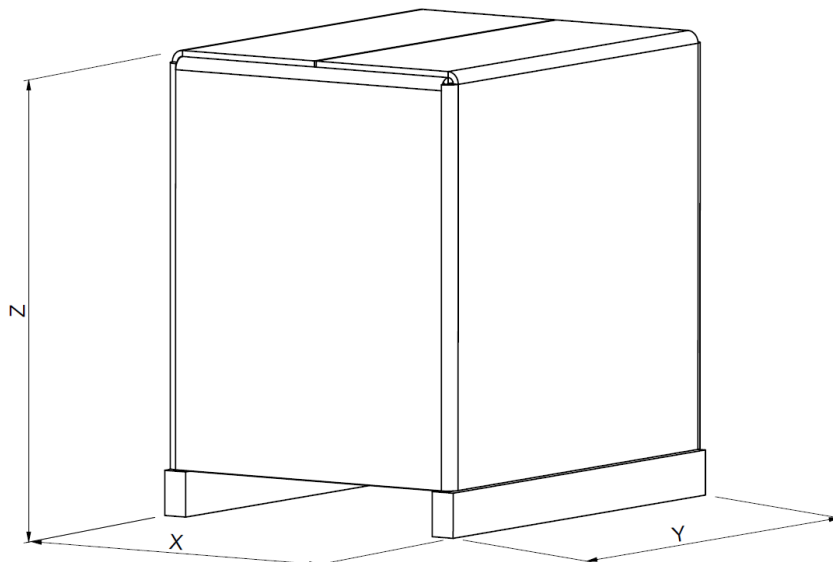

2GP MATRIX SINGLE PHASE

	Booster type	Overall dimensions packing			Booster+packing Weight [kg]
		X	Y	Z	
2GP SINGLE PHASE	2GP MATRIX 3-4T/0.65M	690	890	930	78
	2GP MATRIX 3-5T/0.75M				82
	2GP MATRIX 3-6T/0.9M				85
	2GP MATRIX 3-7T/1.3M				93
	2GP MATRIX 3-8T/1.3M				95
	2GP MATRIX 3-9T/1.5M				99
	2GP MATRIX 5-4T/0.9M				84
	2GP MATRIX 5-5T/1.3M				93
	2GP MATRIX 5-6T/1.3M				93
	2GP MATRIX 5-7T/1.5M	98			
	2GP MATRIX 5-8T/2.2M	1230	830	1365	107
	2GP MATRIX 5-9T/2.2M				109
	2GP MATRIX 10-3T/1.3M				690
	2GP MATRIX 10-4T/1.5M	100			
	2GP MATRIX 10-5T/2.2M	111			
	2GP MATRIX 10-6T/2.2M	112			
2GP MATRIX 18-3T/2.2M	1230	830	1365	119	

The dimensions may change without notice.

2GP MATRIX THREE PHASE

	Booster type	Overall dimensions packing			Booster+packing Weight [kg]
		X	Y	Z	
2GP THREE PHASE	2GP MATRIX 3-4T/0.65				78
	2GP MATRIX 3-5T/0.75	690	890	930	82
	2GP MATRIX 3-6T/0.9				85
	2GP MATRIX 3-7T/1.3				93
	2GP MATRIX 3-8T/1.3	1230	830	1365	95
	2GP MATRIX 3-9T/1.5				99
	2GP MATRIX 5-4T/0.9	690	890	930	84
	2GP MATRIX 5-5T/1.3				93
	2GP MATRIX 5-6T/1.3				93
	2GP MATRIX 5-7T/1.5	1230	830	1365	98
	2GP MATRIX 5-8T/2.2				107
	2GP MATRIX 5-9T/2.2				109
	2GP MATRIX 10-3T/1.3	690	890	930	93
	2GP MATRIX 10-4T/1.5				100
	2GP MATRIX 10-5T/2.2				111
	2GP MATRIX 10-6T/2.2				112
	2GP MATRIX 18-3T/2.2	1230	830	1365	119
	2GP MATRIX 18-4T/3				127
2GP MATRIX 18-5T/4				146	
2GP MATRIX 18-6T/4				148	

The dimensions may change without notice.

2GPE MATRIX

	Booster type	Overall dimensions packing			Booster+packing Weight [kg]
		X	Y	Z	
2GPE E-SPD+	2GPE MATRIX 3-3T/0.65 ESPM				74
	2GPE MATRIX 3-4T/0.65 ESPT (ESPM)				74
	2GPE MATRIX 3-5T/0.75 ESPT(ESPM)	690	890	780	75
	2GPE MATRIX 3-6T/0.9 ESPT(ESPM)				77
	2GPE MATRIX 3-7T/1.3 ESPT(ESPM)				86
	2GPE MATRIX 3-8T/1.3 ESPT				88
	2GPE MATRIX 3-9T/1.5 ESPT	1230	830	1365	92
	2GPE MATRIX 5-3T/0.65 ESPM				71
	2GPE MATRIX 5-4T/0.9 ESPT(ESPM)				76
	2GPE MATRIX 5-5T/1.3 ESPT(ESPM)	690	890	780	85
	2GPE MATRIX 5-6T/1.3 ESPT(ESPM)				86
	2GPE MATRIX 5-7T/1.5 ESPT				91
	2GPE MATRIX 5-8T/2.2 ESPT	1230	830	1365	91
	2GPE MATRIX 5-9T/2.2 ESPT				91
	2GPE MATRIX 10-4T/1.5 ESPT	690	890	780	93
	2GPE MATRIX 10-5T/2.2 ESPT				94
	2GPE MATRIX 10-6T/2.2 ESPT	1230	830	1365	95

The dimensions may change without notice.

CONTROL PANEL FIXED SPEED

2EP-E SPECIFICATION

- **SERIES 2EP-E M UA (single-phase power output)**
- **SERIES 2EP-E T UA (three-phase power output)**

Electrical panel (protection and control) for two electropumps. Manual or automatic operation through pressure transmitter. The panel is configured to start the two pumps alternately in stand-by to pressure transmitter. The electrical panel protects the motors against overload and phase failure. Any protection devices that intervene are signalled on the panel itself and remotely through no voltage contacts. The protection device against overload and phase failure resets automatically three times, and manually after the fourth intervention.

TECHNICAL FEATURES

- P.MIN= Operation against dry running (tripped by a level float or minimum pressure switch) with automatic reset once water supply is restored, with warning lamp.
- TRP= control by pressure transmitter
- PR1= Pump n. 1 start/stop (not included in the pressure set)
- PR2= Pump n. 2 start/stop (not included in the pressure set)
- Automatic start sequence alternation
- Motor protection against overload with automatic reset for three times and manual reset the fourth time
- Motor line protection against short-circuits with fuses for motor startup
- Transformer and auxiliary circuit protection with fuses
- Remote signalling, through NC-NO no voltage contact, of the protection devices that intervene

Version		2EP-E M UA	2EP-E T UA
Power source	Frequency	50/60 Hz	
	Phase	Single-phase	Three-phase
	Voltage	230 V ± 10%	400 V ± 10%
	Power	0.55 ÷ 2.2 kW	1.1 ÷ 7.5 kW
Others	Protection degree	IP 56	
	Ambient Temperature	-10°C + 50°C up to 7.5 kW	
	Pressurisation units	2 pumps	
	Relative humidity	50% a 40°C MAX (90% a 20°C)	
	Max altitude	1000 m (a.s.l.)	
Directives	2014/35/EU (LVD), 2014/30/EU (EMC), 2011/65/EU (RoHS II)		

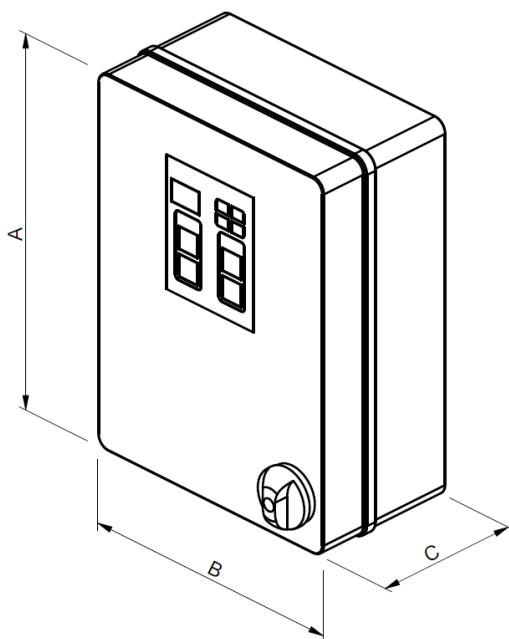

2EP-E M UA MODELS TABLE

Model	Single pump Power [kW]	I Calibration [A]	Motor fuse	Dimensions AxBxC [mm]	Weight [kg]
2EP-E 0,55 M	0,55	2x4,5	6A aM (10x38)	240 x 190 x 90	1,5
2EP-E 1,1 M	1,1	2x9	10A aM (10x38)	240 x 190 x 90	1,5
2EP-E 1,5 M	1,5	2x12	12A aM (10x38)	240 x 190 x 90	1,5
2EP-E 2,2 M	2,2	2x15	20A aM (10x38)	300 x 220 x 120	2,2

The dimensions may change without notice.

2EP-E T UA MODELS TABLE

Model	Single pump Power [kW]	I Calibration [A]	Motor fuse	Dimensions AxBxC [mm]	Weight [kg]
2EP-E 1,1 T	1,1	2x3.5	4A am (10x38)	300 x 220 x 120	3,5
2EP-E 2,2 T	2,2	2x5	8A am (10x38)	300 x 220 x 120	3,5
2EP-E 4 T	4	2x9	12A am (10x38)	300 x 220 x 120	3,5

The dimensions may change without notice.

CONTROL PANEL VARIABLE SPEED E-SPD+ SPECIFICATION

On board electronic device for controlling electropumps, employing inverter technology. Starts and stops the pump and modulates the speed of the motor in relation to the water demand on the system, to maintain the operating pressure setting. Provides excellent comfort for the end user, significant energy savings and increased service life, the typical advantages of inverter controlled autoclave systems. E-SPD is an inverter that could be installed on the terminal box. It can be adapted on horizontal and vertical pumps. E-SPD can protect the system against overpressure, overcurrent, voltage fluctuation, dry run and water leak. The connection for this mode is made by communication line ON/OFF.

E-SPD+				
Power	Version	MT	TT	
	Power Voltage	Single-phase 230 V	Three-phase 400 V	
	Output Voltage (pump)	Three-phase 230 V	Three-phase 400 V	
	Output frequency	50 ÷ 60Hz		
	Maximum pump power	2.2 kW	4 kW	
	Max I in	20 A	12 A	
	Max I out	11 A	11 A	
Others	Pressure setpoint	0.5 ÷ 40 bar		
	Protection degree	IP 55		
	Ambient Temperature	-10 ÷ +40°C		
	Pressurisation units	2-3 pumps		
	Weight	2,7 Kg		
	Protection	Dry-running		
		Over/under voltage		
		Short-circuit		
Overload				
Overtemperature				
Pressure sensor fault				
Directives	2014/35/EU (LVD), 2014/30/EU (EMC), 2011/65/EU (RoHS II)			

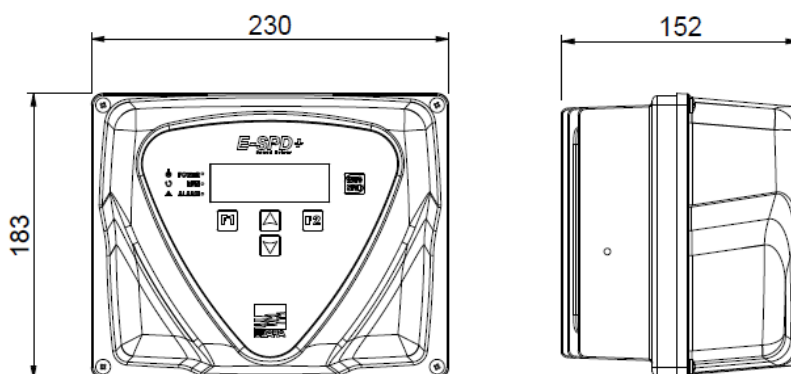

The dimensions may change without notice.

SP (EFC and MFC) SPECIFICATION

The control panels SP EFC/MFC series inverters modulate the operation of electropumps in response to control by the pressure transmitter (transducer measuring flow or other external signal 4-20 mA), regulating the speed of the electropumps to keep system demand constant. If the electronic controller or pressure transmitter fails, a system of pressure switches controls the pumps directly (if present).

VERSION

- “EFC”: Control panel for two or more electric pumps, with a single inverter with pump exchange
- “MFC”: Control panel for two or more electric pumps, with an inverter for each individual electropump

EFC / MFC		
Power	Power Voltage	Three-phase 400 V
	N° phases	Three phase without the use of neutral
	Frequence	50/60Hz
	Pump power	From 1.5kW up to 30kW
	Protection degree	IP55 up to 2.2kW IP44 3kW and above
	Ambient Temperature	-10°C + 40°C
	Pressurisation units	2 or 3 pumps
Directives	2014/35/EU (LVD), 2014/30/EU (EMC), 2011/65/EU (RoHS)	

Single inverter with exchange pump (SP EFC)

Panel type	Pump motor power (Three-phase)	Starting (Emergency / fixed speed pumps)	Option
2/3 pumps	1.5÷7.5 kW	Direct	Inverter pump Exchange
	11÷30kW	Star-Delta	

Multi-inverter: one inverter for each pump (SP MFC)

Panel type	Pump motor power (Three-phase)	Starting (Emergency / fixed speed pumps)
2/3 pumps	1.5 - 7,5 kW	Inverter ramp
	11 - 30 KW	Inverter ramp

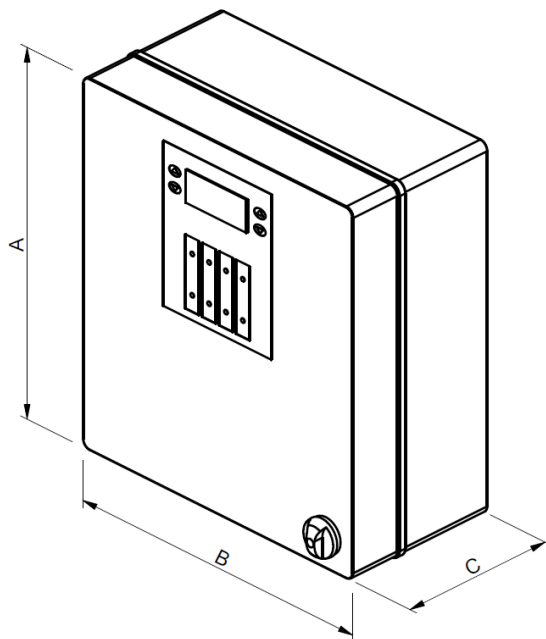

2SP EFC MODELS TABLE

Model	Motor power [kW]	Current [A]	Dimensions A-B-C [mm]	Weight [Kg]
2SP EFC 1,5T-2	2x1.5	2x3,7	450x400x200	25
2SP EFC 2,2T-2	2x2.2	2x5,3	450x400x200	25
2SP EFC 3T-2	2x3	2x7,2	450x400x250	25
2SP EFC 4T-2	2x4	2x9	450x400x250	25

The dimensions may change without notice

3SP EFC MODELS TABLE

Model	Motor power [kW]	Current [A]	Dimensions A-B-C [mm]	Weight [Kg]
3SP EFC 1,5T-2	3x1.5	3x3,7	450x400x200	30
3SP EFC 2,2T-2	3x2.2	3x5,3	450x400x200	30
3SP EFC 3T-2	3x3	3x7,2	450x400x250	30
3SP EFC 4T-2	3x4	3x9	450x400x250	30

The dimensions may change without notice

2SP MFC MODELS TABLE

Model	Motor power [kW]	Current [A]	Dimensions A-B-C [mm]	Weight [Kg]
2SP EFC 1,5T-2	2x1.5	2x3.7	500x400x200	28
2SP EFC 2,2T-2	2x2.2	2x5.3	500x400x200	28
2SP EFC 3T-2	2x3	2x7.2	600x400x250	28
2SP EFC 4T-2	2x4	2x9	600x400x250	28

The dimensions may change without notice

3SP MFC MODELS TABLE

Model	Motor power [kW]	Current [A]	Dimensions A-B-C [mm]	Weight [Kg]
3SP MFC 1,5T-2	3x1.5	3x3.7	800x600x250	33
3SP MFC 2,2T-2	3x2.2	3x5.3	800x600x250	33
3SP MFC 3T-2	3x3	3x7.2	800x600x250	33
3SP MFC 4T-2	3x4	3x9	800x600x250	33

The dimensions may change without notice

PROTECTION PANEL SPECIFICATION

Connection box for inverter :

- Connects the inverters with the power supply point.
- Equipped with circuit breakers on individual lines

Power source	Frequency	50/60 Hz	
	Phase	Single-phase	Three-phase
	Voltage	230 V ± 10%	400 V ± 10%
	Power	0.37 ÷ 3 kW	0.37 ÷ 15 kW
Others	Protection degree	IP 55	
	Ambient Temperature	-5°C + 40°C	
	Pressurisation units	2 pumps	
	Relative humidity	50% a 40°C MAX (90% a 20°C)	
	Max altitude	1000 m (a.s.l.)	
Directives	2014/35/EU (LVD), 2014/30/EU (EMC), 2011/65/EU (RoHS II)		

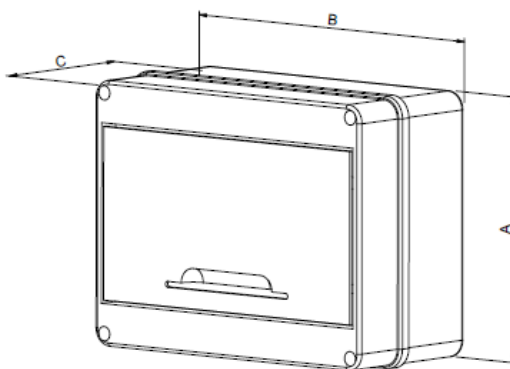

Model	N° Pumps	Power [kW]	Dimensions A-B-C [mm]	Max Current [A]
PROT.IP65 2P. 3M 20A NJ	2	2x3	160x200x90	2x20
PROT.IP65 2P. 4T 16A J		2x4	200x250x110	2x16
PROT.IP65 3P. 3M 20A NJ	3	3x3	160x200x90	3x20
PROT.IP65 3P. 4T 16A J		3x4	250x250x140	3x16

The dimensions may change without notice



EBARA Pumps Europe S.p.A.

Via Torri di Confine 2/1 int. C
36053 Gambellara (Vicenza),
Italia Tel.: +39 0444 706811
Fax: +39 0444 405811
ebarapumps.epe@ebaracom
www.ebaraeurope.com

EBARA Corporation

11-1, Haneda Asahi-cho, Ota-ku,
Tokyo 144-8510
Japan
Tel. +81 3 6275 7598
Fax +81 3 5736 3193
www.ebara.com

