

Looking ahead,
going beyond expectations
Ahead > Beyond

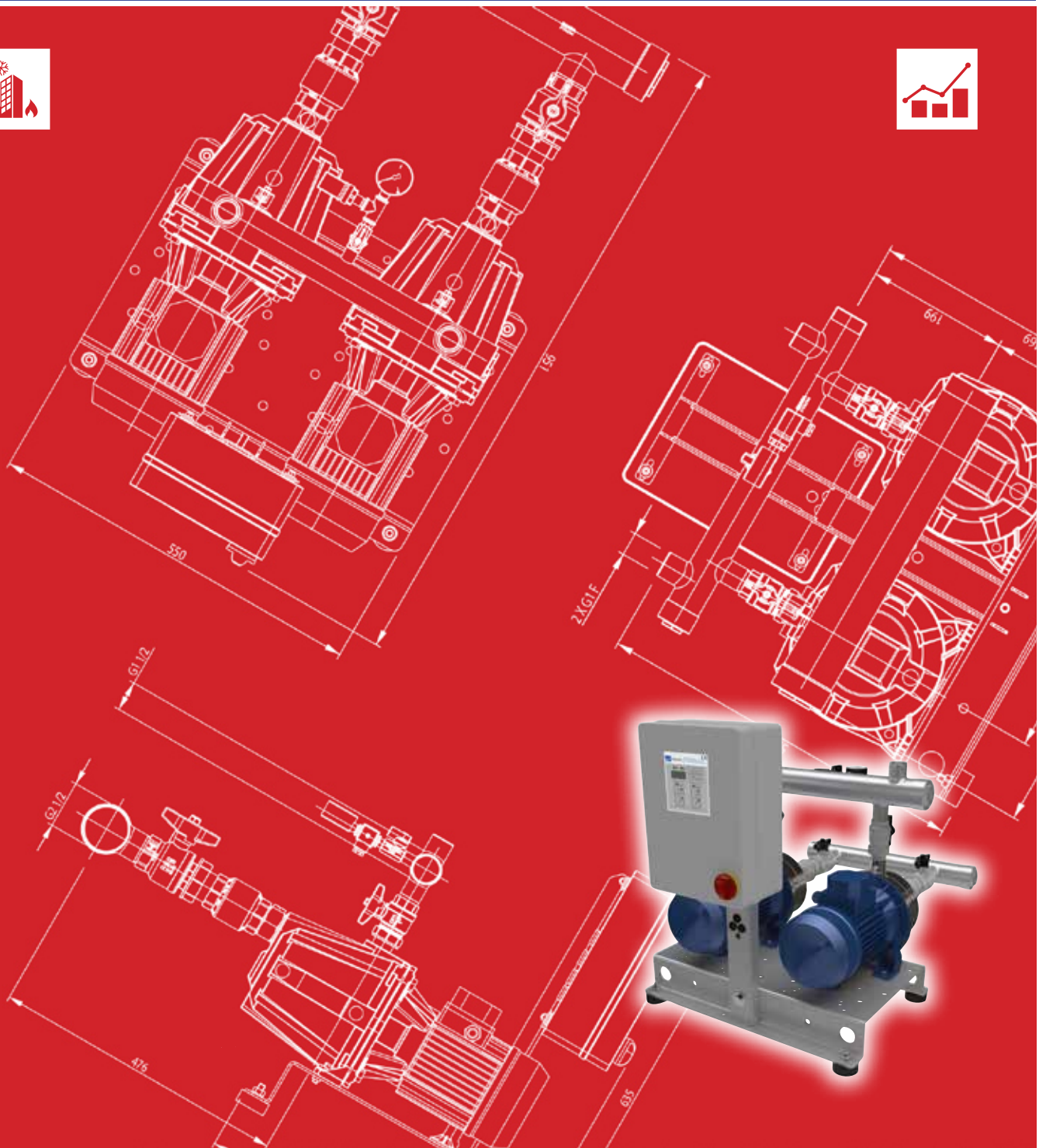

GP 2CDX

Data Book 50Hz



INDEX

	Page
INDEX	2
DEFINITION AND USE OF PRESSURISATION UNITS	101
TYPICAL APPLICATIONS	101
OPERATING CONDITIONS	101
TESTS AND TRIALS	101
MECHANICAL AND HYDRAULIC TESTS	101
ELECTRICAL TESTS	102
PRINCIPLE OF OPERATION OF GP PRESSURISATION UNITS	102
Principle of Operation of GPE Pressurisation UNITS with E-SPD+	102
Principle of Operation of GPE Pressurisation UNITS with an EFC control panel	102
Principle of Operation of GPE Pressurisation UNITS with an MFC control panel	103
Fig. 1 - TWO PUMP UNIT WITH CONSTANT PRESSURE REGULATION	104
GP PRESSURISATION UNIT WATER CIRCUIT DIAGRAM	104
GPE PRESSURISATION UNIT WATER CIRCUIT DIAGRAM	105
TYPE KEY	106
NAME PLATE	106
PRODUCT SPECIFICATIONS	201
HYDRAULIC COMPONENTS AND CONTROL	201
ELECTRIC PANEL	202
TECHNICAL PUMP DATA	202
TECHNICAL MOTOR DATA	203
PERFORMANCE RANGE	401
RESEAU BOOSTER SET 2GP(.) 2CDX	401
CURVE SPECIFICATION 2GP(.)	402
SELECTION CHART 2GP(.) 2CDX	403
PERFORMANCE CURVE 2GP(.)	404
2GP(.) 2CDX 70/10	404
2GP(.) 2CDX 70/12	405
2GP(.) 2CDX 70/15	406
2GP(.) 2CDX 70/20	407
2GP(.) 2CDX 120/15	408
2GP(.) 2CDX 120/20	409
2GP(.) 2CDX 120/30	410
2GP(.) 2CDX 120/40	411
2GP(.) 2CDX 200/30	412
2GP(.) 2CDX 200/40	413

2GP(.) 2CDX 200/50	414
2GP CONSTRUCTION	601
EXTERNAL VIEW 2GP 2CDX	601
OVERALL DIMENSIONS 2GP BOOSTER SET	602
2GP 2CDX	602
PACKING	603
CONTROL PANEL FIXED SPEED	801
2EP-E SPECIFICATION	801
CONTROL PANEL VARIABLE SPEED	803
E-SPD+ SPECIFICATION	803
SP (EFC and MFC) SPECIFICATION	804
PROTECTION PANEL SPECIFICATION	806

DEFINITION AND USE OF PRESSURISATION UNITS

In situations in which a municipal water mains is lacking or insufficient for the proper operation of the services, one must install a pressurization unit to provide acceptable pressure and flow rates to even in the most unfavourable services. Pressurisation units are used wherever there is a need to increase the pressure, or to pressurise a water circuit. **EBARA GP pressurisation units** are automatic systems with 2 or more pumps operating in parallel, designed to provide a simple and reliable solution to the most common requirements for maintenance of water supply pressure for apartment buildings, hotels, centres, offices and schools as well as providing auxiliary service in industrial and agricultural applications. They stand out for their robust construction, compact size, excellent efficiency and silent operation. GP units are equipped for connection to membrane and air cushion autoclaves. They are controlled by pressure transmitter for EP-E and by pressure switches for EP. GPE units (with INVERTER) are controlled by pressure transmitter.

TYPICAL APPLICATIONS

INDUSTRY	BUILDING SERVICE	WATER SUPPLY
		

OPERATING CONDITIONS

EBARA GP-GPE pressurisation units can be used, in their standard versions, for civil, industrial and agricultural applications, as follows:

- building service
- water lifting and handling
- A/C
- heating
- irrigation
- washing systems

The conveyed fluid must be: clean, potable, ground or mixed water, free of solid or fibrous suspensions and aggressive chemical substances.

The units must be installed under cover, protected from the weather and freezing.

- Conveyed water temperature (depending on pumps).
- Ambient operating temperature 0 - 40°C, no higher than 1000 m above sea level.
- Max relative humidity 50% at +40°C.

NB: The system available NPSH must be greater than the NPSH demanded from the pump. For applications with different technical specifications, uses and climatic conditions (type of vector fluid, marine and aggressive industrial conditions), please contact our sales network.

TESTS AND TRIALS

Before shipping, all EBARA pressurisation units are subject to hydraulic, mechanical and electrical testing.

MECHANICAL AND HYDRAULIC TESTS

- Pressure switch calibration (only if present)
- Pump direction of rotation
- Mechanical testing of moving parts and running noise (on each pump)
- Tightness test with delivery port closed and nameplate rating tests
- MANUAL trials (using button on control panel) for each pump
- AUTOMATIC trials (using switch on control panel) for unit

ELECTRICAL TESTS

- Earthing system continuity
- Applied voltage (dielectric rigidity)
- Insulation resistance

PRINCIPLE OF OPERATION OF GP PRESSURISATION UNITS

When water is demanded, it is first drawn from the autoclave tank (if present). This demand for water, with the pumps stopped, lowers the pressure until the first pressure switch (for EP version) or the pressure transmitter (for EP-E version) starts the first electropump. If the output flow is greater than the delivery capacity of a single pump, the pressure continues falling until the second pressure switch (for EP version) or the pressure transmitter (for EP-E version), thus starting the second pump. This happens for all pumps in the unit. When the water demand stops or reduces, the system pressure rises, the pressure switches (for EP version) or the pressure transmitter (for EP-E version) shutting off the pumps one by one. This is done in inverse order to that in which the motors were started up, the number of hourly starts per pump is reduced and they are all used to the same extent.

NB: By connecting a float switch or minimum pressure switch to the control panel (both for demand from the first accumulation tank and from the water circuit itself) one can prevent the most frequent cause of pump failure: dry running

Principle of Operation of GPE Pressurisation UNITS with E-SPD+

GPE units with E-SPD+ are designed to operate with each pumps controlled by an INVERTER installed on board its motor. The system is controlled by an MASTER INVERTER in relation to the reference signal supply by a pressure transmitters (4 - 20 mA passive). As the system pressure varies, the MASTER pump varies its rotary speed to restore it to the setpoint. If the water demand exceeds the capacity of the pump, the second variable speed pump cuts in and, pump goes into regulation mode to maintain the pressure setpoint; this happens for all the pumps in the unit. If the water demand drops off, the pressure tends to increase and the latest pump gradually reduces its speed to restore the correct operating pressure. This results in the regulation of the speed of the other pumps, until they gradually turn off. Once the system pressure has been restored and the water demand is 0, the MASTER pump switches off automatically.

Principle of Operation of GPE Pressurisation UNITS with an EFC control panel

EFC multiple pump control units power pump n. 1 with the INVERTER to modulate system performance in relation to the reference signal while the other pumps are run at maximum nominal speed (around 2900 rpm) and started and stopped in relation to demand.

These means there are two distinct primary electrical circuits:

- n. 1 - INVERTER startup/control of a single pump,
- n. 2 - contactor startup (direct or star/delta) of the other pumps.

The system is controlled by an electronic controller in relation to the reference signal supply by a pressure transmitter, flow meter or other unified control signal (4 - 20 mA passive).

If the electronic controller or pressure transmitter fails, a system of pressure switches controls the pumps directly (if present).

- In case of water distribution at constant pressure (Fig.1), the electronic controller is connected to the pressure transmitter on the units' delivery manifold, which outputs a signal proportional to the circuit pressure. When the pressure drops due to water demand, the pressure transmitter signal also drops and the controller starts and controls the speed of the first pump with the INVERTER to restore the reference/ operating pressure. If the pump's flow rate is lower than demand, the circuit pressure will continue to drop and the system responds by increasing the pump's speed. Once pump n. 1 reaches its maximum speed and demand is still in excess of its delivery, the controller will start pump n. 2 at maximum speed. The speed of pump n. 1 is immediately modulated so as to establish the operating pressure. If the pressure drops even further and pump n. 1 is once again running at maximum speed, the controller starts up pump n. 3, and so on for all pumps in the unit. If the

water demand drops off, the pressure tends to increase and the controller reduces the speed of pump n. 1 to restore the correct operating pressure. At this point, the controller will stop one of the pumps running at maximum speed, while the speed of pump n. 1 is modulated to maintain the reference pressure. As the pressure continues to increase due to reduced demand, once the minimum speed of pump n. 1 is reached once more the controller will stop pump n. 3 and then pump n. 2. Once the demand for water has completely ceased, the controller reduces the speed of pump n. 1 to its minimum and after a set delay (around 1 minute) stops this pump too. The next time the system is started up, the INVERTER controlled pump will no longer be pump n. 1, but n. 2. The INVERTER controlled pump thus rotates through all pumps in sequence.

Principle of Operation of GPE Pressurisation UNITS with an MFC control panel

MFC multiple pump control panels power each pump with an INVERTER to modulate system performance in relation to the reference signal. MFC controllers differ from EFC controller from the point of view of their construction, since instead of having a single INVERTER to control all the pumps, each pump has its own INVERTER. The two types of control panel differ in construction, but they have the same type of operation by the controller, which responds to the reference signal output by a pressure transmitter or other unified control (4 - 20 mA passive). If the electronic controller or pressure transmitter fails, a system of pressure switches controls the INVERTERS directly.

- In case of water distribution at constant starting pressure (Fig.1), the electronic controller is connected to the pressure transmitter on the units' delivery manifold, which outputs a signal proportional to the circuit pressure. When the pressure drops due to water demand, the pressure transmitter signal also drops and the controller starts and controls the speed of the first pump with the INVERTER to restore the reference/ operating pressure. If the pump's flow rate is lower than demand, the circuit pressure will continue to drop and the system responds by increasing the pump's speed. Once pump n. 1 reaches its maximum speed and demand is still in excess of its delivery, the controller will start pump n. 2, also at variable synchronous speed. The controller will modulate the speed of the two pumps to restore the operating pressure; the modulating frequency is the same for both pumps. If the pressure drops even further and pumps n. 1 and 2 are once again running at maximum speed, the controller starts up pump n. 3, and then pump n. 4, if present. When the water demand is reduced the pressure will end to increase, as does the pressure transmitter output value. The controller thus reduces the speed of pumps n. 1, 2, 3 and 4 (they are all controlled at the same speed) to restore the reference/ operating pressure. If the pumps' flow rate is greater than demand, the circuit pressure will continue to increase and the system responds by decreasing the speed of the pumps until it reaches the minimum speed setting. At this point, the controller will stop pump n. 4, while the speed of pumps n. 1, 2 and 3 is modulated to maintain the reference pressure. As the pressure continues to increase due to reduced demand, once the minimum speed setting is reached again, the controller will stop pump n. 3 and modulate the speed of pumps n. 1 and 2. This continues in sequence as the demand continues to fall, until the unit is completely stopped.

Fig. 1 - TWO PUMP UNIT WITH CONSTANT PRESSURE REGULATION

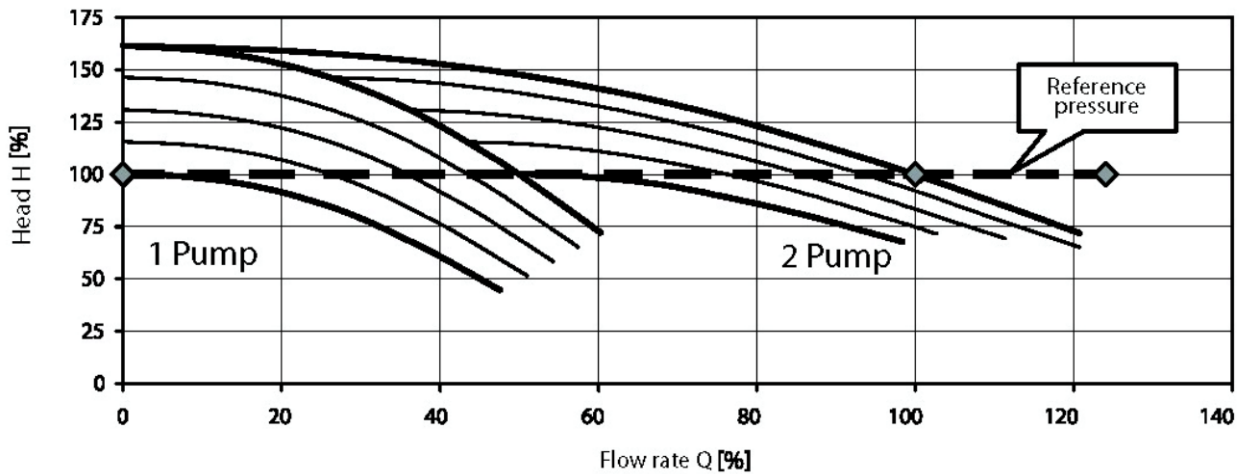

GP PRESSURISATION UNIT WATER CIRCUIT DIAGRAM

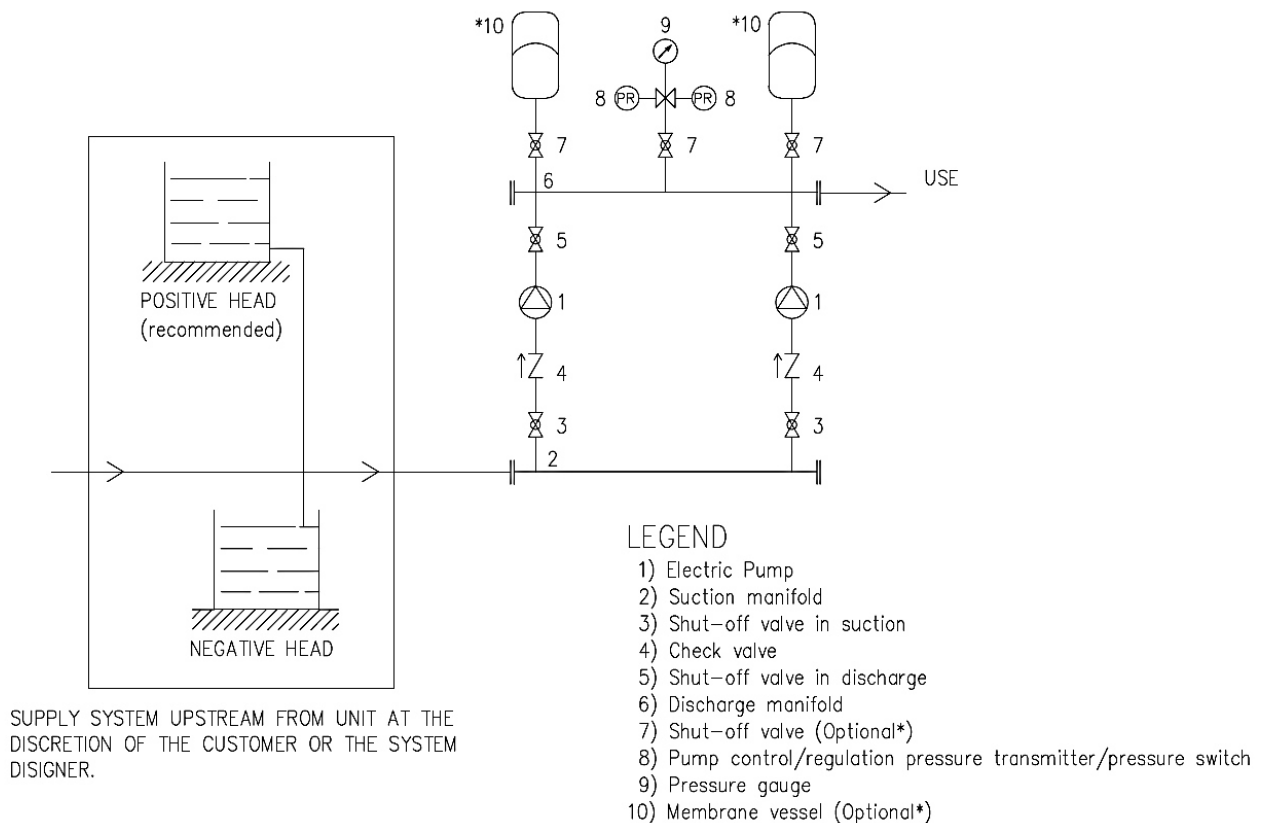

GPE PRESSURISATION UNIT WATER CIRCUIT DIAGRAM

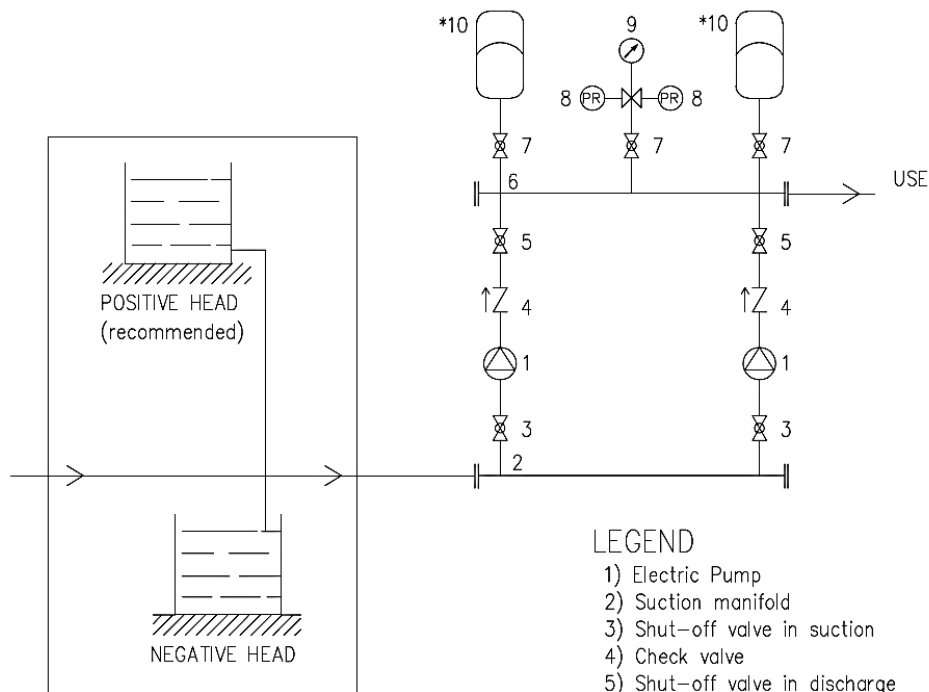

SUPPLY SYSTEM UPSTREAM FROM UNIT AT THE DISCRETION OF THE CUSTOMER OR THE SYSTEM DESIGNER.

LEGEND

- 1) Electric Pump
- 2) Suction manifold
- 3) Shut-off valve in suction
- 4) Check valve
- 5) Shut-off valve in discharge
- 6) Discharge manifold
- 7) Shut-off valve (Optional*)
- 8) Pump control/regulation pressure transmitter/pressure switch
- 9) Pressure gauge
- 10) Membrane vessel (Optional*)

TYPE KEY 2GP(.) 2CDX

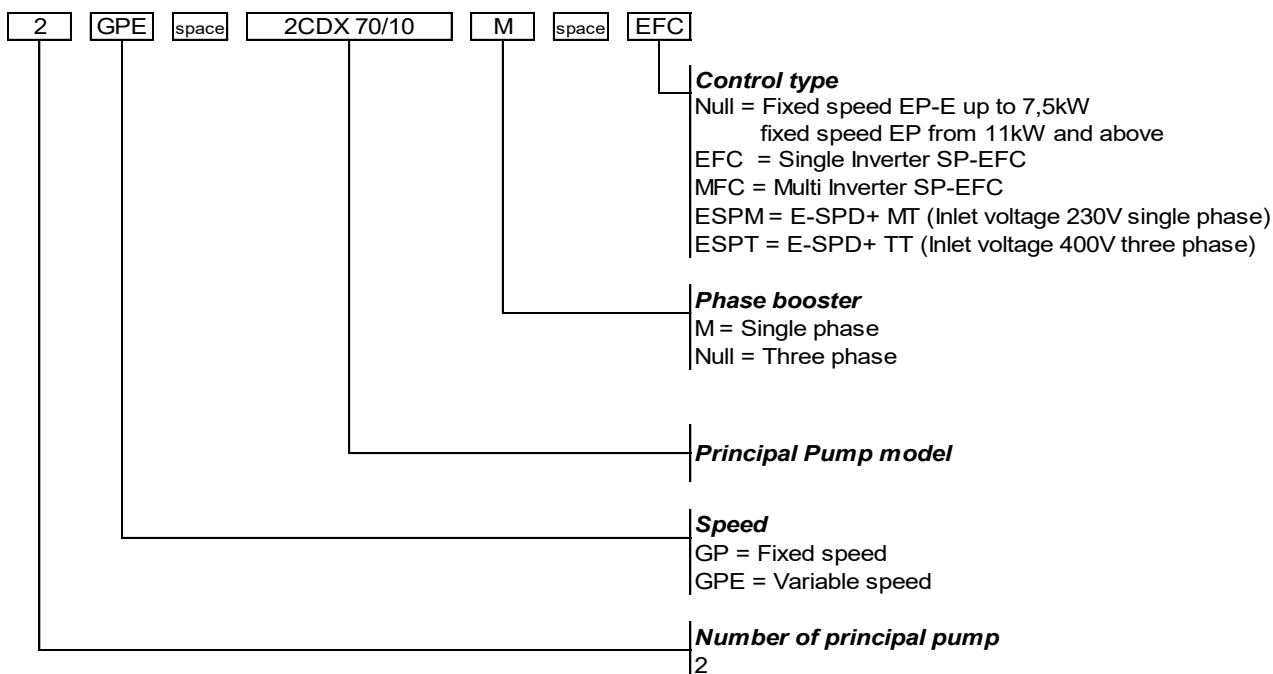

NAME PLATE



EBARA

EBARA Pumps Europe S.p.A.
 Via Campo Sportivo, 30
 38023 Cles (TN), ITALY
 Phone +39 0444 706811
 V.A.T.: 01234660221



EAC CE
 MADE IN ITALY



GRUPPO DI PRESSURIZZAZIONE IDRICA

TYPE	①
P/N	②
S/N	③

- 1) "TYPE" booster model
- 2) "P/N" booster item number
- 3) "S/N" booster serial number

PRODUCT SPECIFICATIONS HYDRAULIC COMPONENTS AND CONTROL

BOOSTER SET						
2CDX						
Operating range	Version		70	120	200	
	Nominal flow rate (m3/h)	Single pump		4.8	9.0	12.6
		2GP		9.6	18.0	25.2
	Maximum working pressure		8 bar			
	Liquid temperature range		0÷+60°C [1]			
	Ambient operating temperature (no higher than 1000 m above sea level)		0÷40°C			
Hydraulic components	Frame		Omega sheet Galvanized steel			
	Manifold suction / discharge		Threaded manifold AISI 304			
	Closing manifold		Threaded female cap AISI 304			
	Check valve		Threaded check valve Brass / NBR			
	Ball valve		Threaded ball valve Brass / PTFE			
	Socket for air feeders		Threaded socket Brass			
Control	Pressure gauge		M3A-ABS 50/FR plastic-copper alloy			
	Pressure transmitter		EN 10088-1.4301 (AISI 304) / 1.4404 (AISI 316L)			

[1] For optional version ask the temperature range to the sales department

ELECTRIC PANEL

BOOSTER SET					
2CDX					
Operating range	Version		70	120	200
	Nominal flow rate (m3/h)	Single pump	4.8	9.0	12.6
		2GP	9.6	18.0	25.2
Control panel	Principal Electric panel		EP-E fixed speed		

TECHNICAL PUMP DATA

PUMP					
2CDX					
Operating range	Version		70	120	200
	Maximum working pressure		0.8 Mpa (8 bar)		
	Liquid temperature range		-5°C to +60°C -5°C to +110°C (H-HS-HW-HSW)		
Liquid handled	Liquid type		Clean water		
Key components material	Casing		EN 1.4301 (AISI 304) (AISI 316) only for "L" version		
	Impeller				
	Casing cover				
	Shaft seal		Ceramic/Carbon/NBR		
	Shaft		AISI 304/AISI 316 (wet extension)		
	Bracket		Aluminium (up to 1.5 kW included) Cast iron (2.2 kW and above)		
	Diffuser		AISI 304/AISI 316		
Pipe connection	Suction	G 1" ¼		G 1" ½	
		UNI ISO 228-1			
	Discharge	G 1" UNI ISO 228-1			

TECHNICAL MOTOR DATA

MOTOR				
2CDX				
Power source	Frequency	50 Hz		
	Phase	Single-phase	Three-phase	
	Rotation speed	2800 min-1		
	Power rating	0.75 ÷ 1.5 kW	0.75 ÷ 3.7 kW	
		1 ÷ 2 HP	1 ÷ 5 HP	
Voltage	230 ± 10% V	230/400 ± 10%		
Type	Type	Electric - TEFC		
	Efficiency level	-	IE3 from 0.75 kW up to 3.7 kW	
	N° of poles	2		
	Protection degree	IP 55		
	Insulation class	F		
Others	Capacitor	Built in	-	
	Overload protection	Built in	Provided by the user	
	Casing Material	Aluminium		
	Motor support	Aluminium		

PERFORMANCE RANGE RESEAU BOOSTER SET 2GP(.) 2CDX

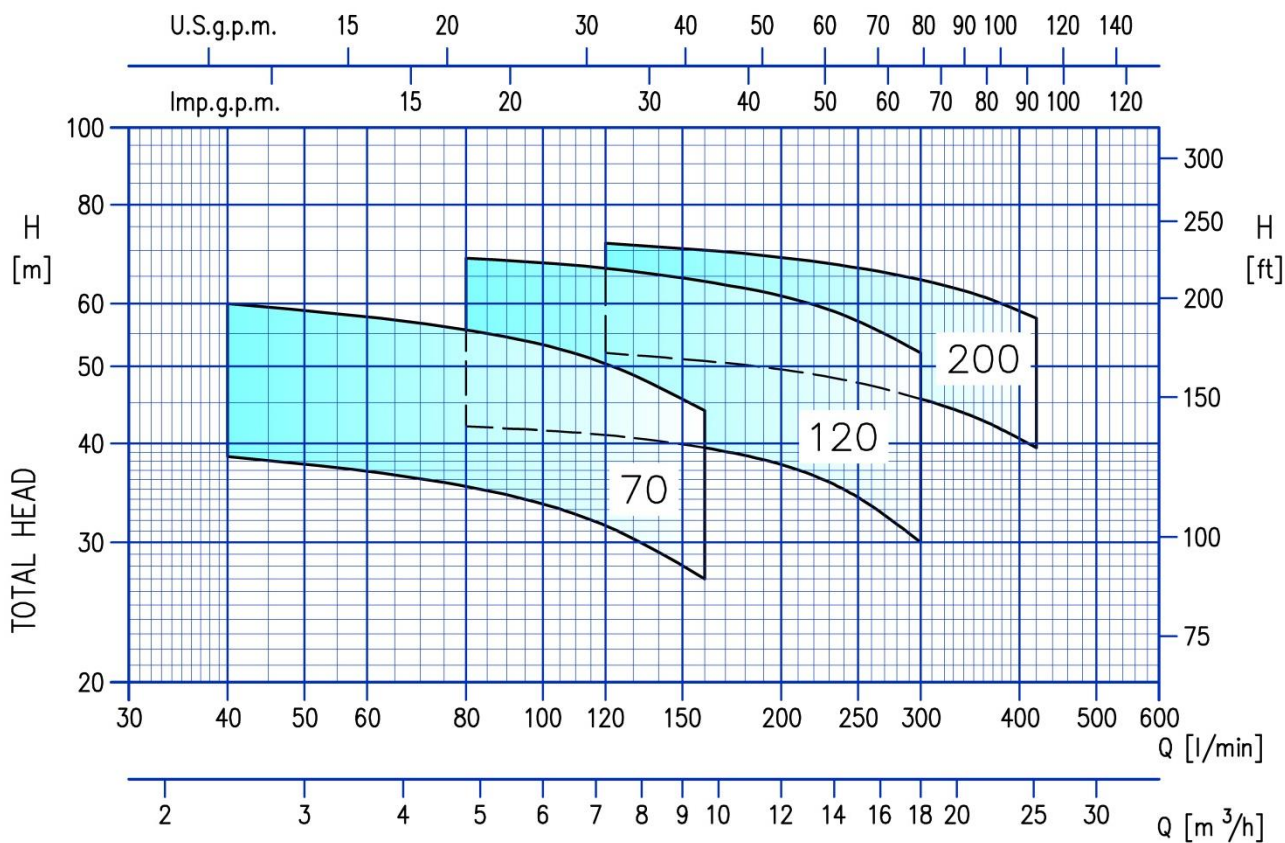

CURVE SPECIFICATION 2GP(.)

The specifications below qualify the curves shown on the following pages.

Tolerances according to ISO 9906:2012 – Grade 3B.

The curves refer to effective speed of asynchronous motors at 50 Hz 2 poles

Measurements were carried out with clean water at 20°C of temperature and with a kinematic viscosity of $\nu = 1 \text{ mm}^2/\text{s}$ (1 cSt).

The NPSH curve is an average curve obtained in the same conditions of performance curves.

During the pump selection, consider to get a safety margin of at least 0.5 m.

The continuous curves indicate the recommended working range. The dotted curve is only a guide.

In order to avoid the risk of over-heating, the pumps should not be used at a flow rate below 10% of best efficiency point. The performance curves refer to 2-pumps booster sets.

Symbols explanation:

- Q = volume flow rate
- H = total head
- P2 = pump power input (shaft power)
- η = pump efficiency
- NPSH = net positive suction head required by the pump
- 1 = one pump on work performance curve
- 2 = two pumps on work performance curve

Pressure drops of the booster's fittings are not considered

SELECTION CHART 2GP(.) 2CDX

Model	Motor		Maximum working pressure (MPa)	Q=Capacity								
	kW	HP		l/min	40	80	120	180	240	300	360	420
				m ³ /h	2.4	4.8	7.2	9.6	14.4	18.0	21.6	25.2
H=Total manometric head in meters												
2GP(.) 2CDX 70/10	0.75+0.75	1+1	0.6	41.0	38.5	35.3	31.5	27.0	-	-	-	-
2GP(.) 2CDX 70/12	0.9+0.9	1.2+1.2		48.0	44.5	40.3	35.5	30.0	-	-	-	-
2GP(.) 2CDX 70/15	1.1+1.1	1.5+1.5		56.0	52.5	48.0	42.8	36.5	-	-	-	-
2GP(.) 2CDX 70/20	1.5+1.5	2+2		64.0	60.0	55.6	50.4	44.0	-	-	-	-
2GP(.) 2CDX 120/15	1.1+1.1	1.5+1.5	0.8	46.0	-	42.0	41.0	39.5	35.0	30.0	-	-
2GP(.) 2CDX 120/20	1.5+1.5	2+2		55.0	-	51.5	49.5	47.4	41.8	36.5	-	-
2GP(.) 2CDX 120/30	2.2+2.2	3+3		63.0	-	59.0	57.0	54.6	49.2	44.0	-	-
2GP(.) 2CDX 120/40	3+3	4+4		71.5	-	68.5	66.5	64.0	58.0	52.0	-	-
2GP(.) 2CDX 200/30	2.2+2.2	3+3		55.0	-	-	52.0	50.8	48.1	45.5	42.7	39.5
2GP(.) 2CDX 200/40	3+3	4+4		66.0	-	-	62.5	61.1	58.0	55.2	52.3	49.0
2GP(.) 2CDX 200/50	3.7+3.7	5+5		75.0	-	-	71.5	70.1	67.0	64.3	61.2	57.5

PERFORMANCE CURVE 2GP(.) 2GP(.) 2CDX 70/10

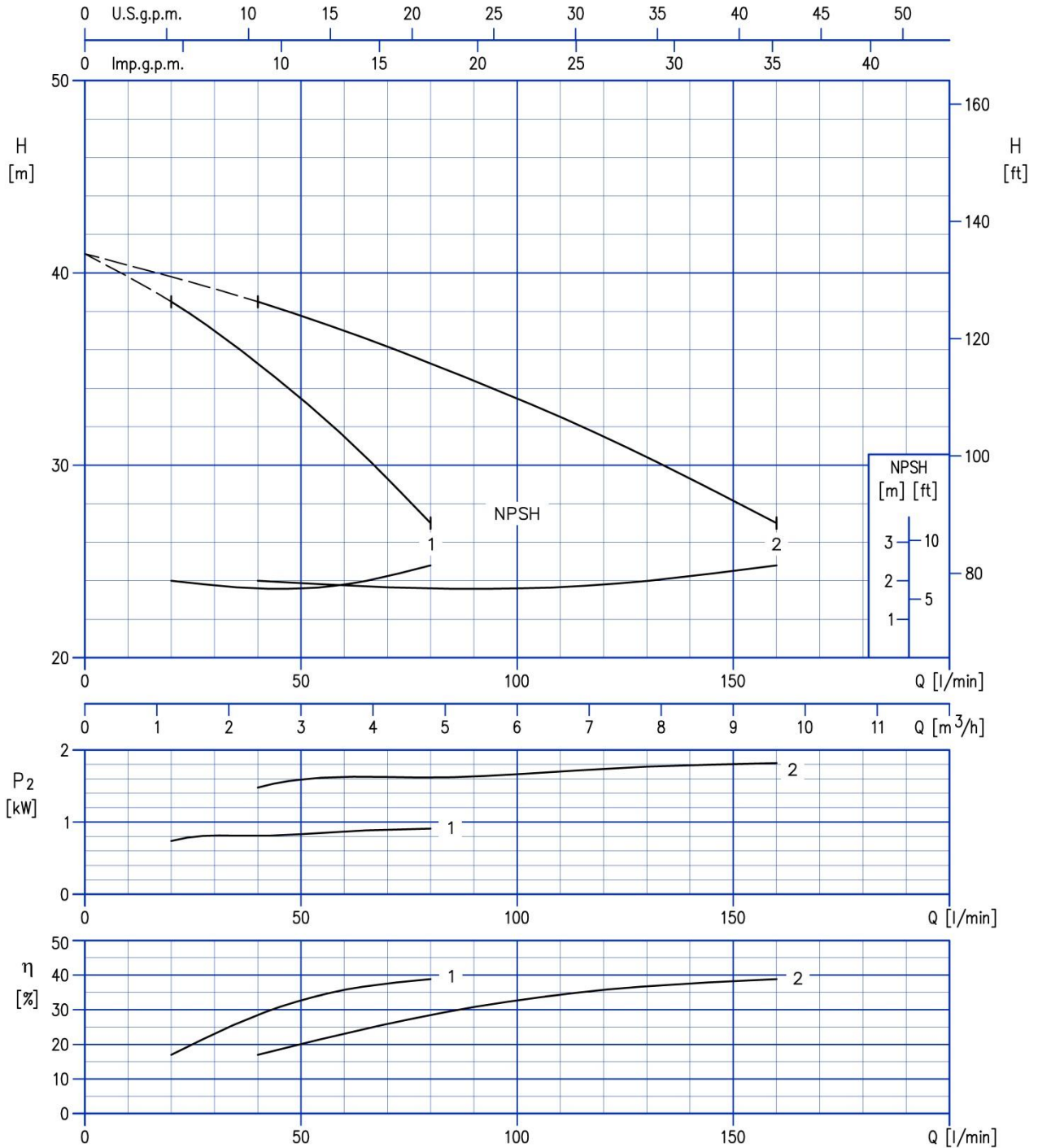

Test standard: ISO 9906: 2012 - Grade 3B

2GP(.) 2CDX 70/12

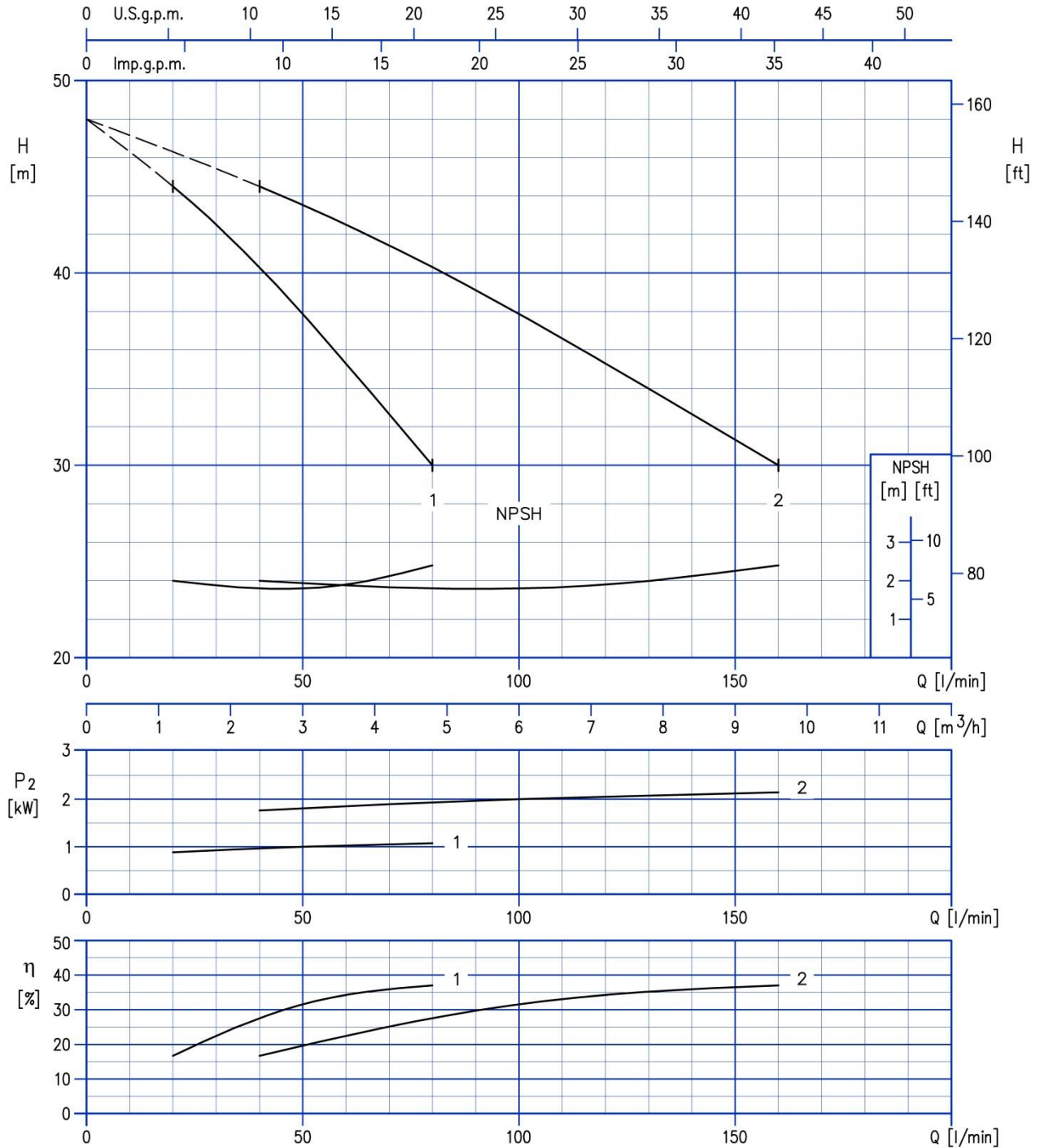

Test standard: ISO 9906: 2012 - Grade 3B

2GP(.) 2CDX 70/15

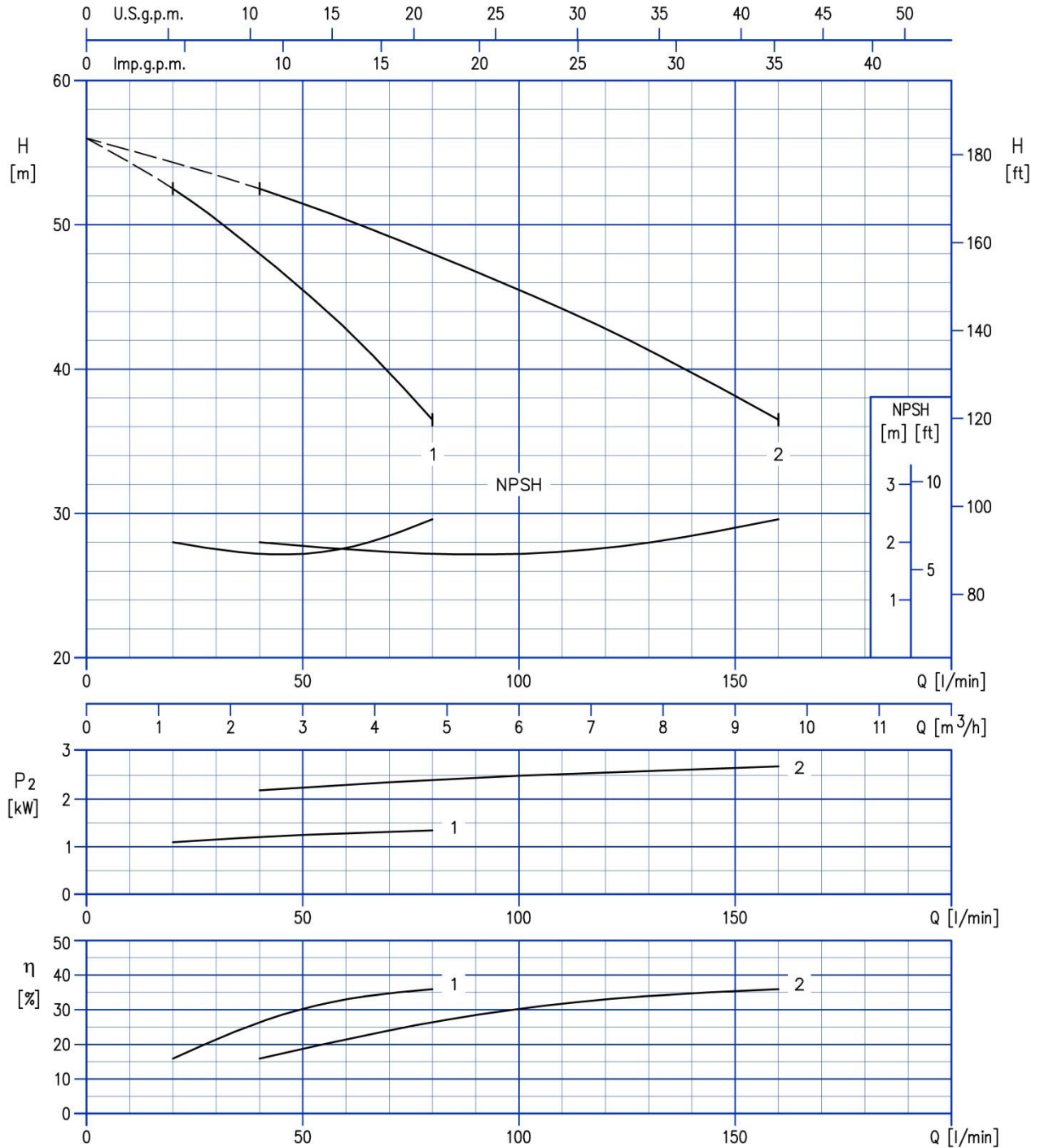

Test standard: ISO 9906: 2012 - Grade 3B

2GP(.) 2CDX 70/20

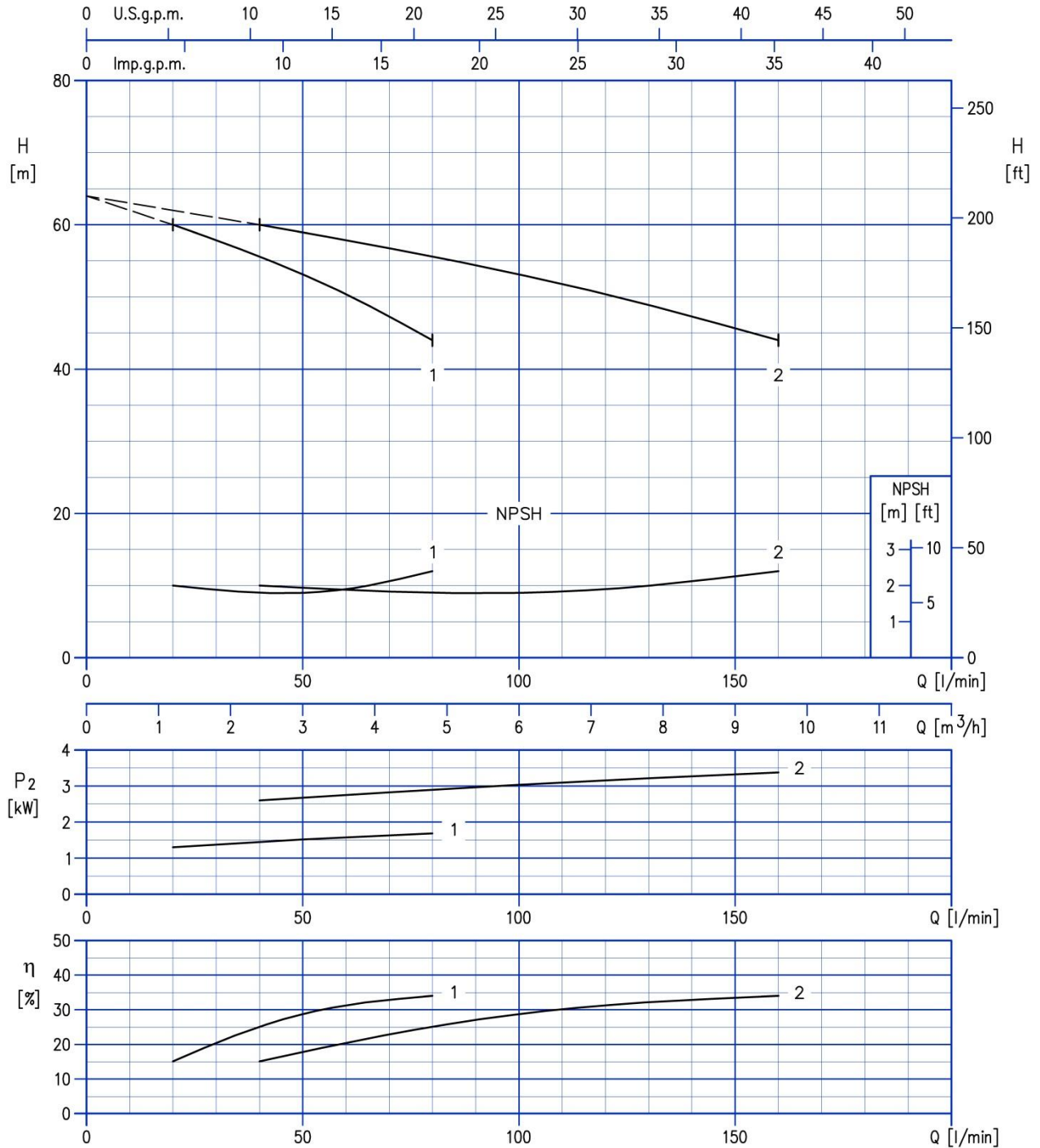

Test standard: ISO 9906: 2012 - Grade 3B

2GP(.) 2CDX 120/15

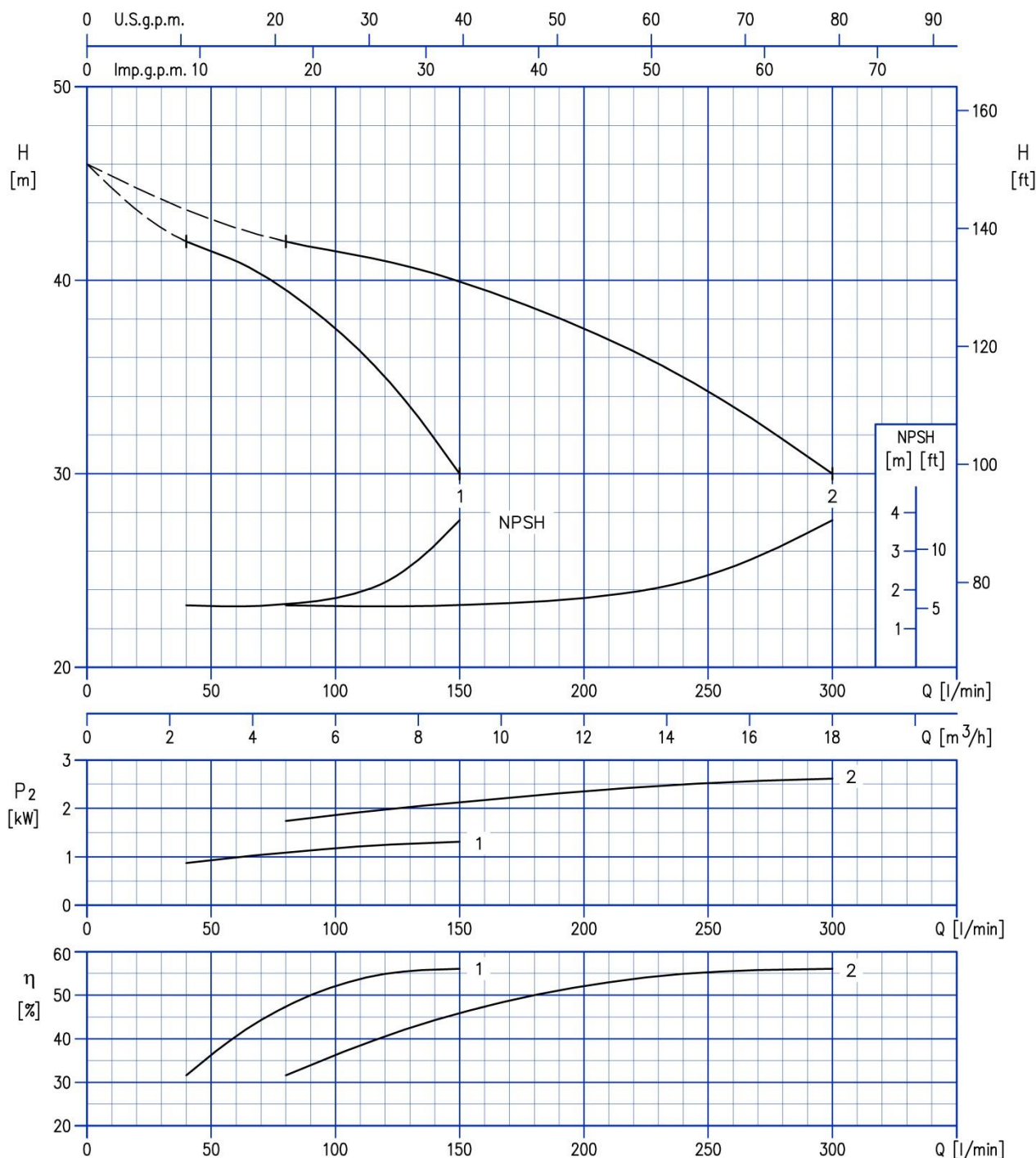

Test standard: ISO 9906: 2012 - Grade 3B

2GP(.) 2CDX 120/20

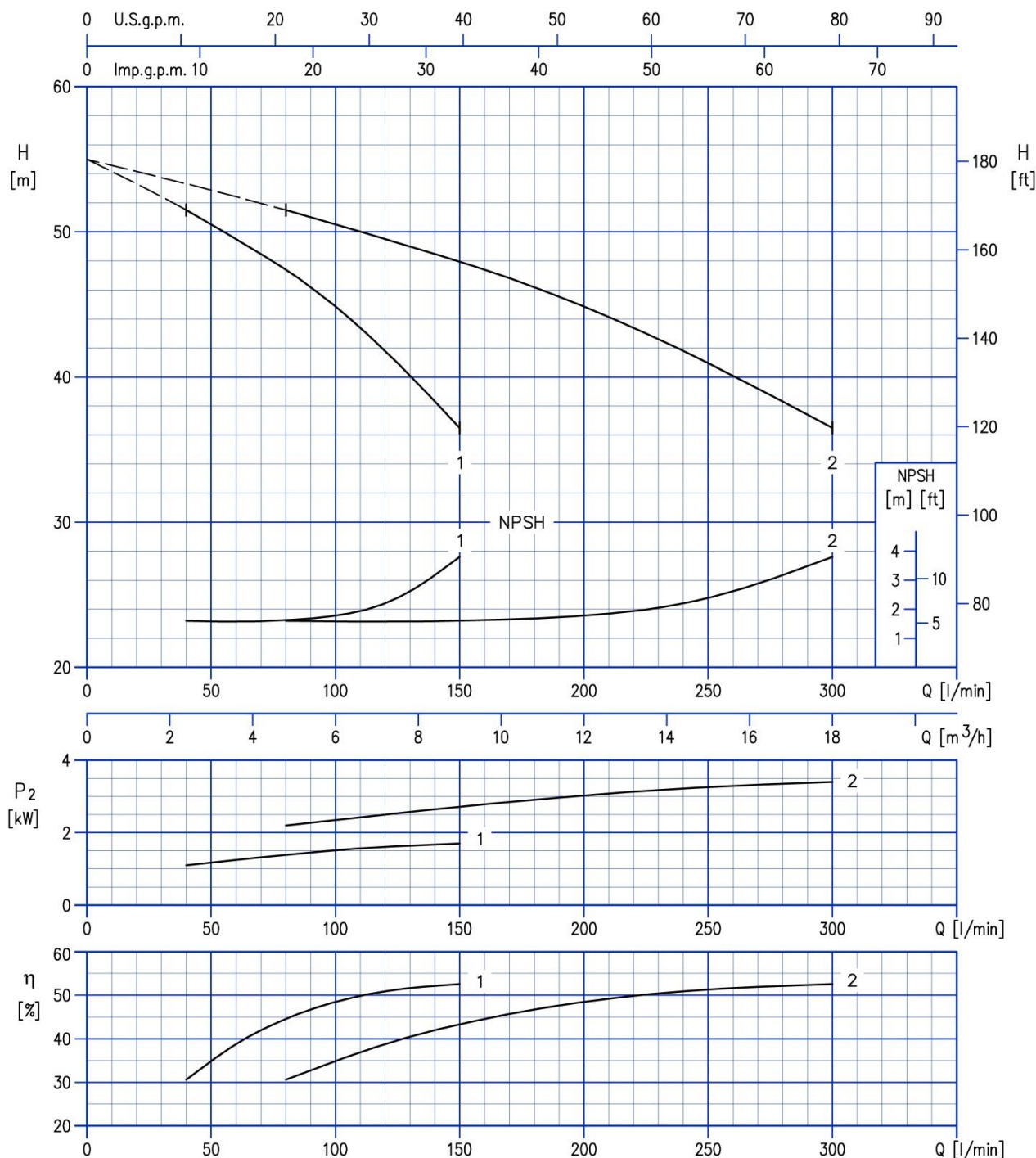

Test standard: ISO 9906: 2012 - Grade 3B

2GP(.) 2CDX 120/30

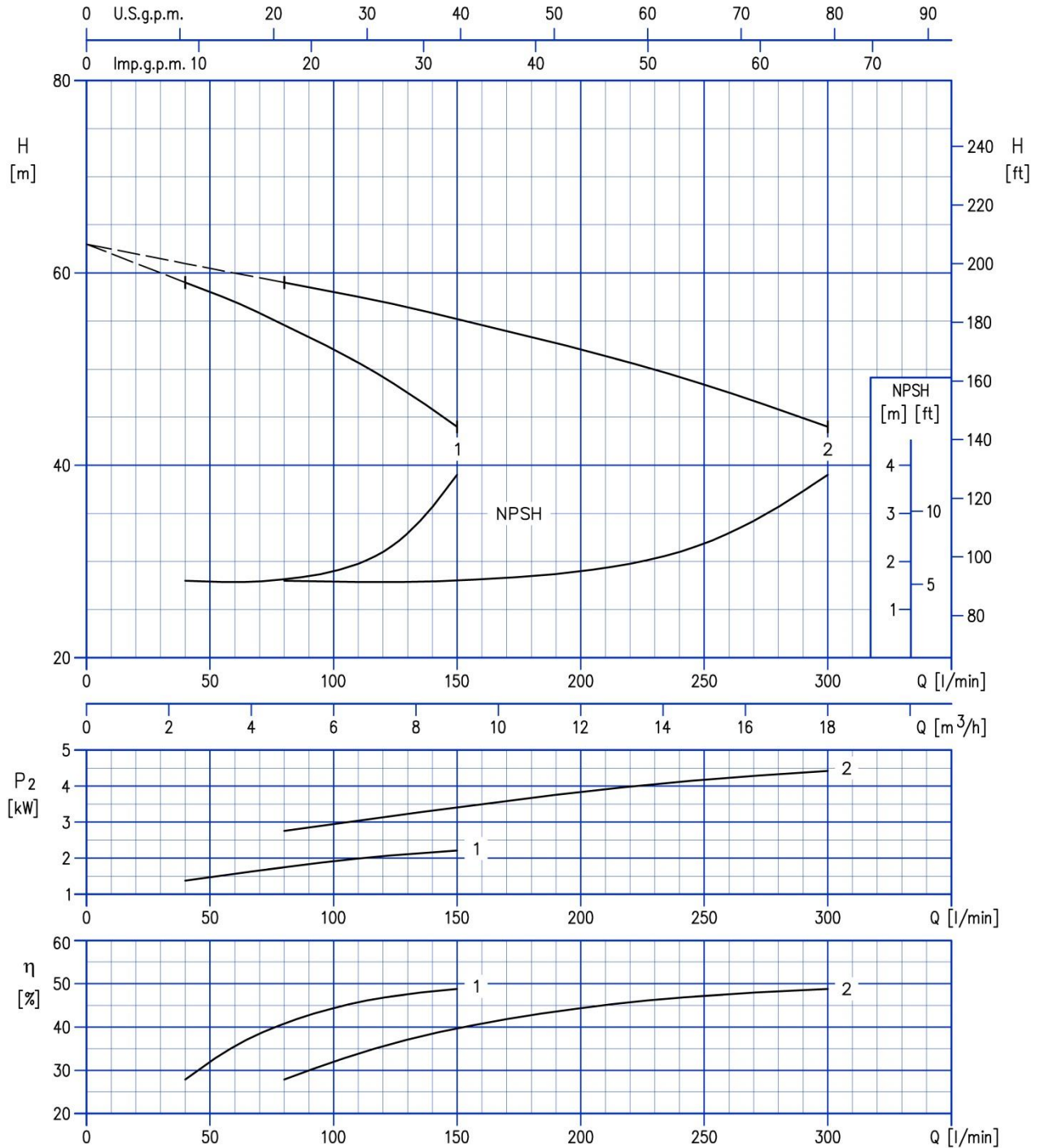

Test standard: ISO 9906: 2012 - Grade 3B

410

2GP(.) 2CDX 120/40

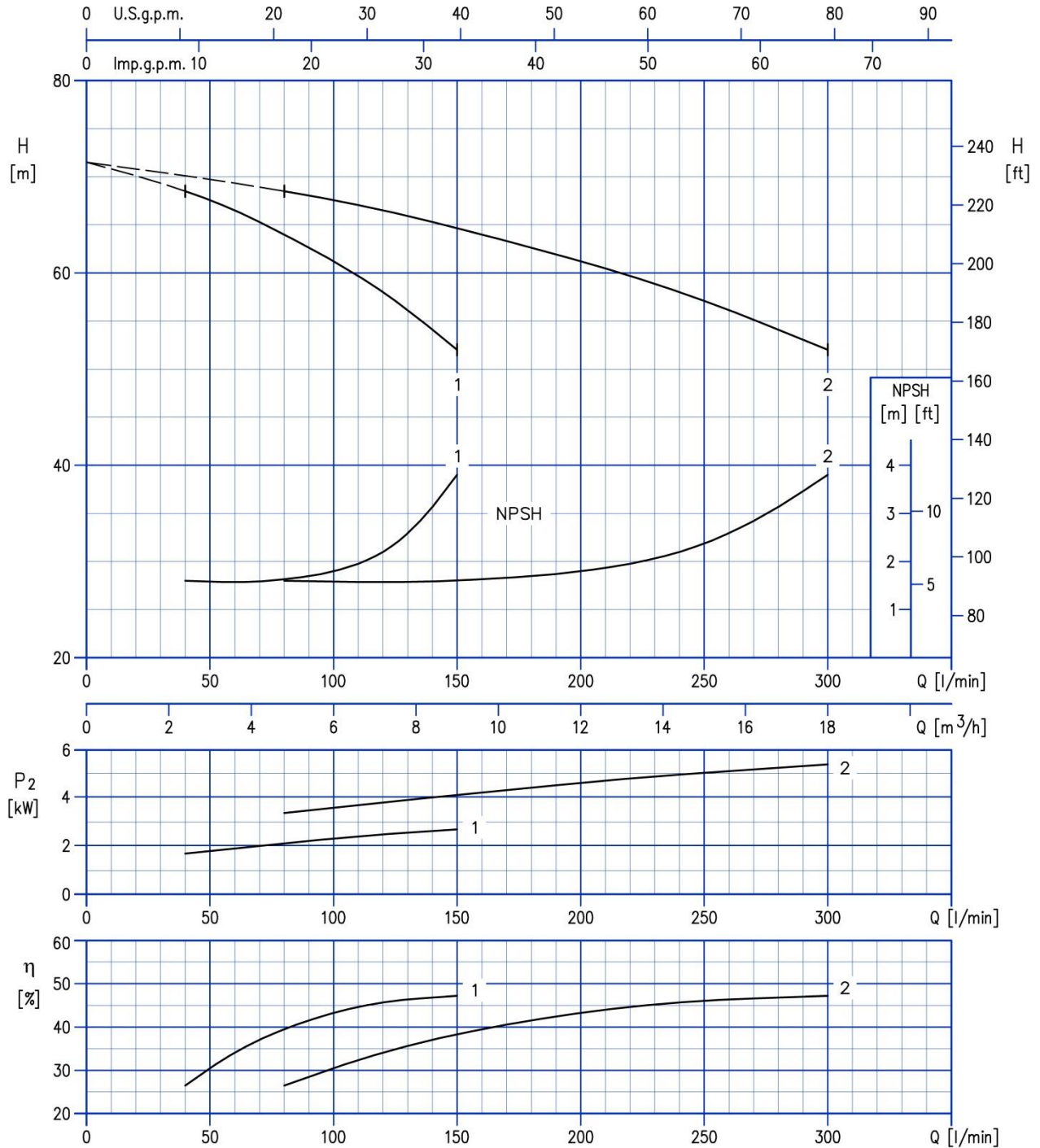

Test standard: ISO 9906: 2012 - Grade 3B

2GP(.) 2CDX 200/30

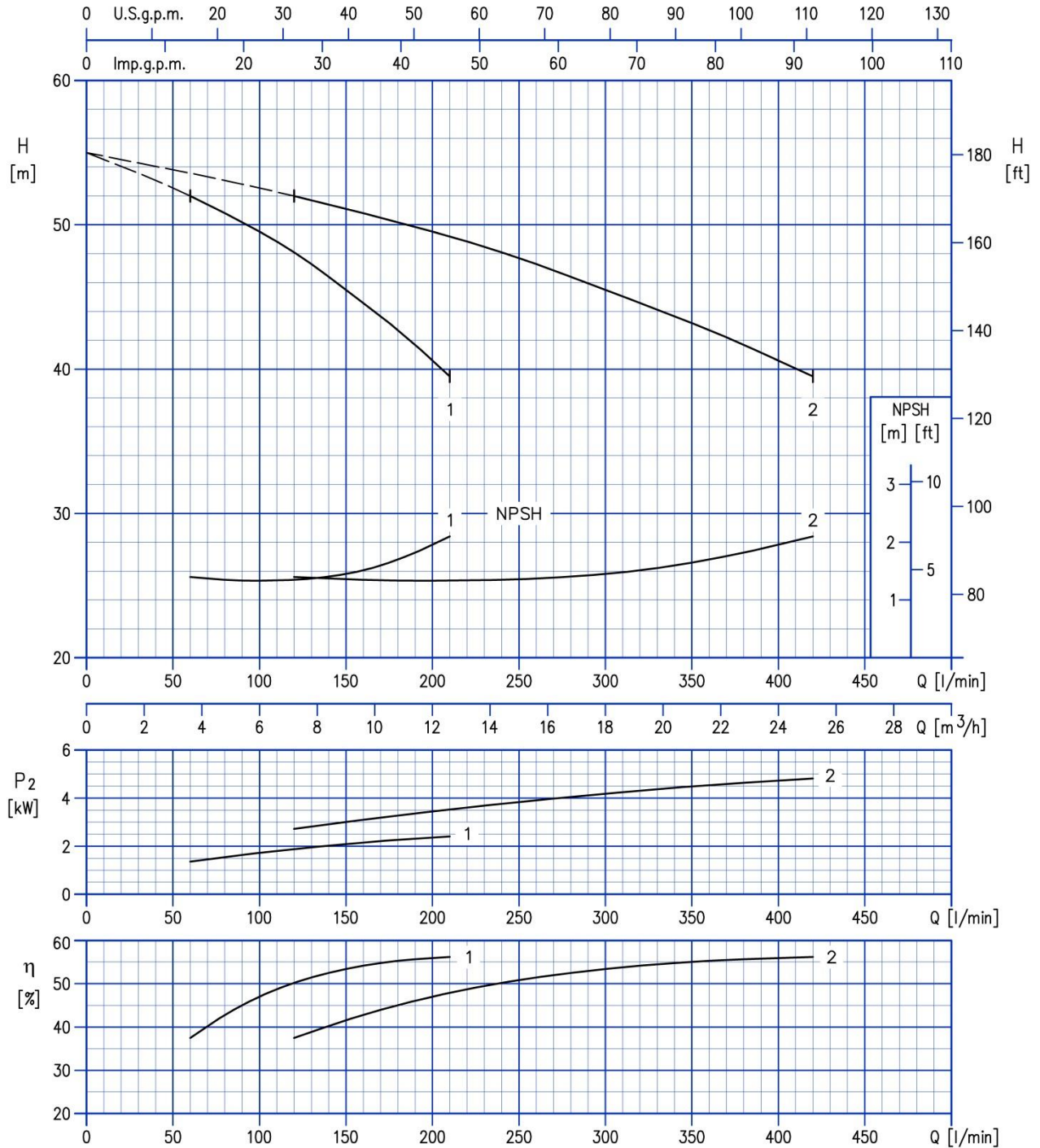

Test standard: ISO 9906: 2012 - Grade 3B

2GP(.) 2CDX 200/40

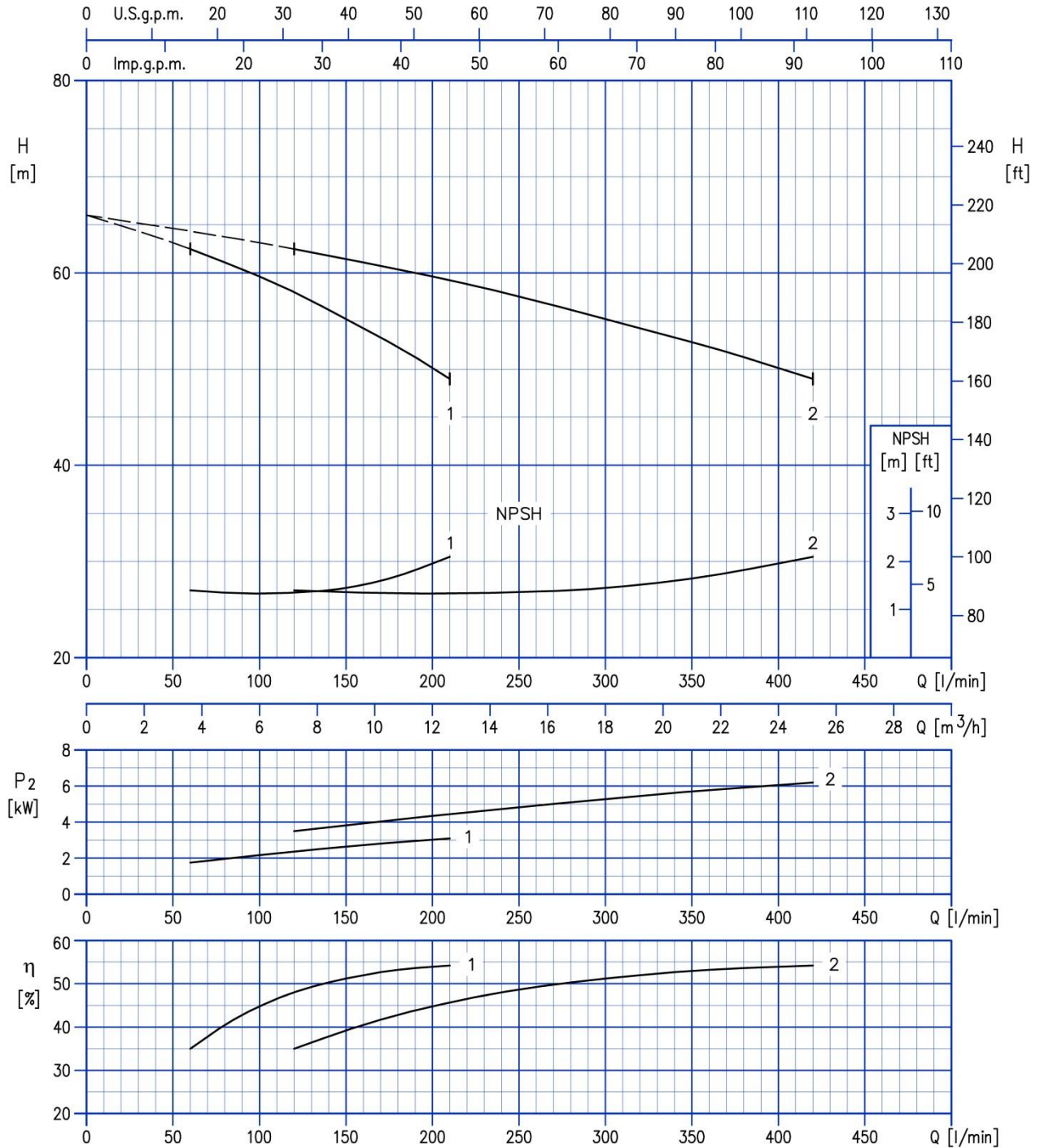

Test standard: ISO 9906: 2012 - Grade 3B

2GP(.) 2CDX 200/50

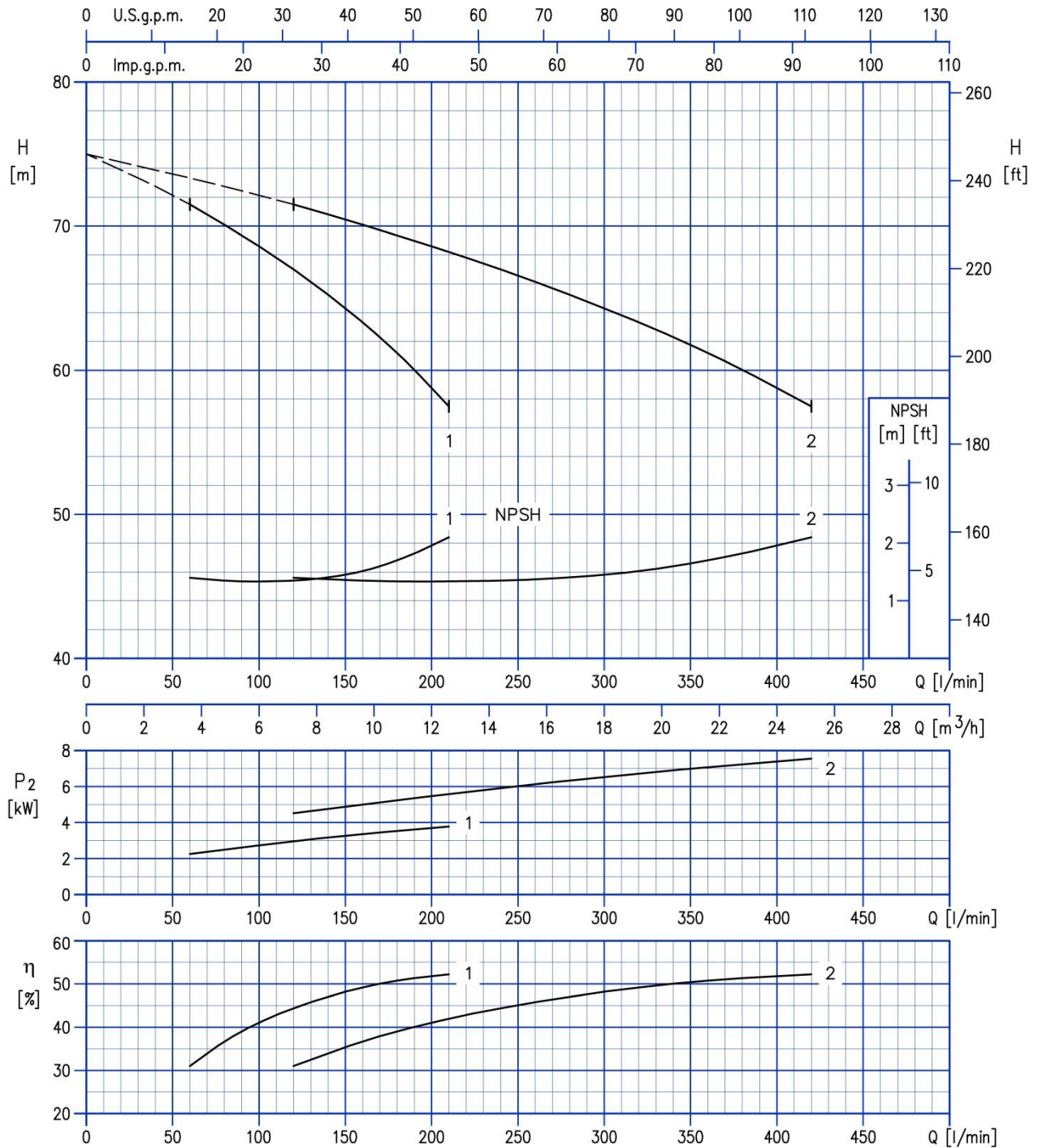

Test standard: ISO 9906: 2012 - Grade 3B

2GP CONSTRUCTION EXTERNAL VIEW 2GP 2CDX

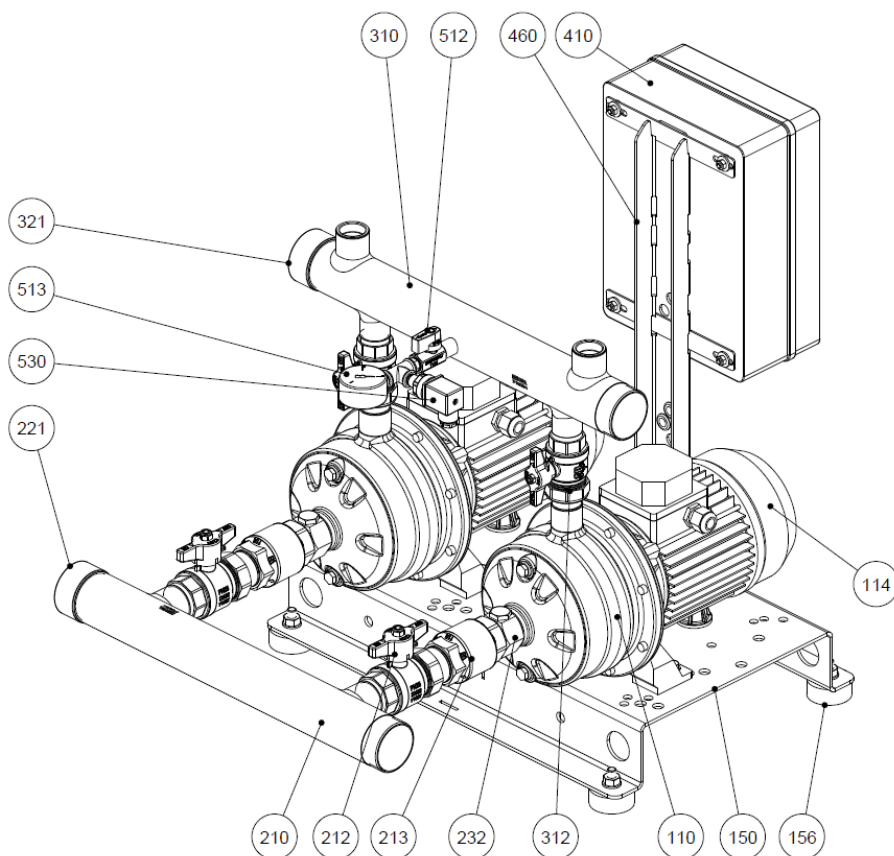

N°	PART NAME	MATERIAL	Quantity
110	Principal pump	-	2
114	Electric motor	-	2
150	Baseplate	Galvanized steel	1
156	Baseplate foot	SBR	4
210	Suction manifold	AISI 304	1
212	Union ball valve	Brass / P.T.F.E.	2
213	Check valve	Brass / NBR	2
221	Threaded female cap	AISI 304	1
232	Nipple for air feeders	Yellow brass	2
310	Discharge manifold	AISI 304	1
312	Union ball valve	Brass / P.T.F.E.	2
321	Threaded female cap	AISI 304	1
410	Control panel	-	1
460	Control panel frame	Galvanized steel	1
512	Ball valve	Brass / P.T.F.E.	1
513	Pressure gauge	Copper alloy / plastic	1
530	Pressure transmitter	-	1

OVERALL DIMENSIONS 2GP BOOSTER SET 2GP 2CDX

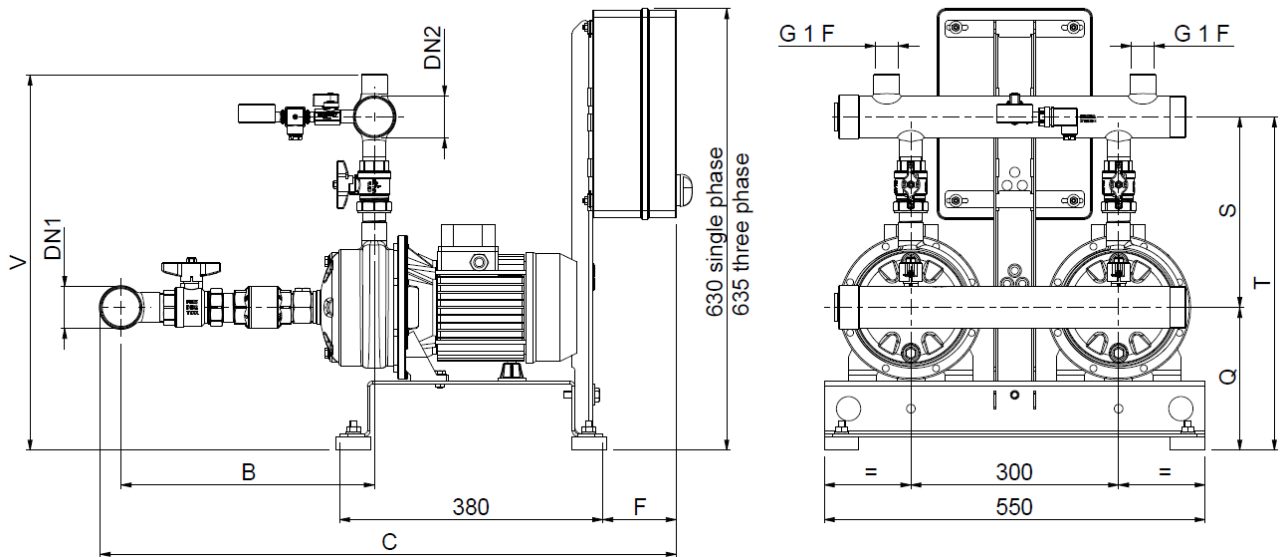

Booster Type	Dimensions [mm]										Weight [kg]		
	DN1	DN2	B	1~ C	3~ C	1~ F	3~ F	Q	S	T	V	1~	3~
2GP 2CDX 70/10(M)	G 2	G 1 1/2	365	785	815	75	105	205	270	475	530	58	59
2GP 2CDX 70/12(M)	G 2	G 1 1/2	365	785	815	75	105	205	270	475	530	59	62
2GP 2CDX 70/15(M)	G 2	G 1 1/2	365	800	830	75	105	220	280	500	550	67	68
2GP 2CDX 70/20(M)	G 2	G 1 1/2	365	800	830	75	105	220	280	500	550	69	74
2GP 2CDX 120/15(M)	G 2	G 2	365	800	830	75	105	205	275	480	540	65	66
2GP 2CDX 120/20(M)	G 2	G 2	365	800	830	75	105	205	275	480	560	67	71
2GP 2CDX 120/30	G 2	G 2	365	-	845	-	105	220	285	505	560	-	87
2GP 2CDX 120/40	G 2	G 2	365	-	845	-	105	220	285	505	540	-	90
2GP 2CDX 200/30	G 2 1/2	G 2	405	-	895	-	105	205	275	480	560	-	90
2GP 2CDX 200/40	G 2 1/2	G 2	405	-	895	-	105	220	285	505	560	-	92
2GP 2CDX 200/50	G 2 1/2	G 2	405	-	895	-	105	220	285	505	560	-	108

Approximate dimensions ± 20mm.
The dimensions may change without notice.

PACKING

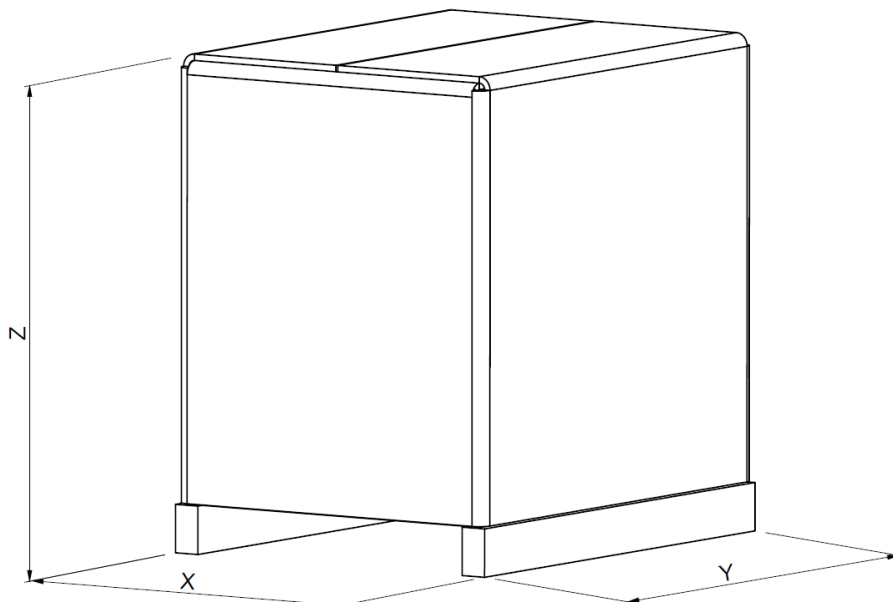

	Booster type	Overall dimensions packing			Booster+packing Weight [kg]
		X	Y	Z	
2GP	2GP 2CDX 70/10(M)	690	890	930	84
	2GP 2CDX 70/12(M)				87
	2GP 2CDX 70/15(M)				93
	2GP 2CDX 70/20(M)				99
	2GP 2CDX 120/15(M)				91
	2GP 2CDX 120/20(M)				96
	2GP 2CDX 120/30				112
	2GP 2CDX 120/40				115
	2GP 2CDX 200/30	1230	830	1365	115
	2GP 2CDX 200/40				117
	2GP 2CDX 200/50				133

The dimensions may change without notice.

CONTROL PANEL FIXED SPEED

2EP-E SPECIFICATION

- **SERIES 2EP-E M UA (single-phase power output)**
- **SERIES 2EP-E T UA (three-phase power output)**

Electrical panel (protection and control) for two electropumps. Manual or automatic operation through pressure transmitter or/and pressure switches. The panel is configured to start the two pumps alternately in stand-by to pressure transmitter or/and pressure switch. The electrical panel protects the motors against overload and phase failure. Any protection devices that intervene are signalled on the panel itself and remotely through no voltage contacts. The protection device against overload and phase failure resets automatically three times, and manually after the fourth intervention.

TECHNICAL FEATURES

- P.MIN= Operation against dry running (tripped by a level float or minimum pressure switch) with automatic reset once water supply is restored, with warning lamp.
- TRP= control by pressure transmitter
- PR1= Pump n. 1 start/stop (not included in the pressure set)
- PR2= Pump n. 2 start/stop (not included in the pressure set)
- Automatic start sequence alternation
- Motor protection against overload with automatic reset for three times and manual reset the fourth time
- Motor line protection against short-circuits with fuses for motor startup
- Transformer and auxiliary circuit protection with fuses
- Remote signalling, through NC-NO no voltage contact, of the protection devices that intervene

Version		2EP-E M UA	2EP-E T UA
Power source	Frequency	50/60 Hz	
	Phase	Single-phase	Three-phase
	Voltage	230 V ± 10%	400 V ± 10%
	Power	0.55 ÷ 2.2 kW	1.1 ÷ 7.5 kW
Others	Protection degree	IP 56	
	Ambient Temperature	-10°C + 50°C up to 7.5 kW	
	Pressurisation units	2 pumps	
	Relative humidity	50% a 40°C MAX (90% a 20°C)	
	Max altitude	1000 m (a.s.l.)	
Directives	2014/35/EU (LVD), 2014/30/EU (EMC), 2011/65/EU (RoHS II)		

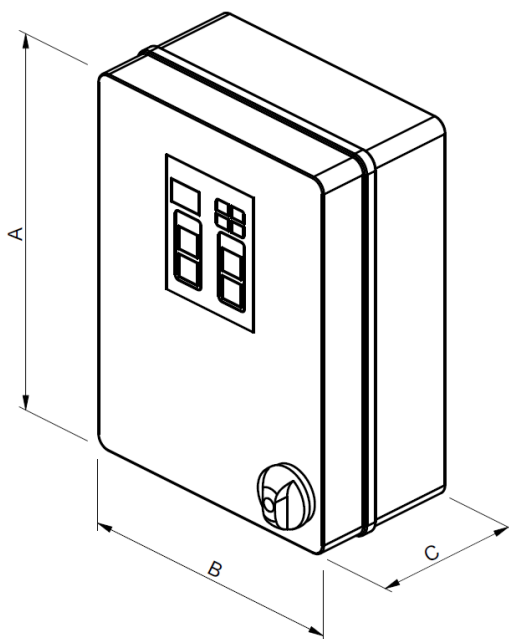

2EP-E M UA MODELS TABLE

Model	Single pump Power [kW]	I Calibration [A]	Motor fuse	Dimensions AxBxC [mm]	Weight [kg]
2EP-E 0,55 M	0,55	2x4,5	6A aM (10x38)	240 x 190 x 90	1,5
2EP-E 1,1 M	1,1	2x9	10A aM (10x38)	240 x 190 x 90	1,5
2EP-E 1,5 M	1,5	2x12	12A aM (10x38)	240 x 190 x 90	1,5

The dimensions may change without notice.

2EP-E T UA MODELS TABLE

Model	Single pump Power [kW]	I Calibration [A]	Motor fuse	Dimensions AxBxC [mm]	Weight [kg]
2EP-E 1,1 T	1,1	2x3.5	4A am (10x38)	300 x 220 x 120	3,5
2EP-E 2,2 T	2,2	2x5	8A am (10x38)	300 x 220 x 120	3,5
2EP-E 4 T	4	2x9	12A am (10x38)	300 x 220 x 120	3,5

The dimensions may change without notice.

CONTROL PANEL VARIABLE SPEED E-SPD+ SPECIFICATION

On board electronic device for controlling electropumps, employing inverter technology. Starts and stops the pump and modulates the speed of the motor in relation to the water demand on the system, to maintain the operating pressure setting. Provides excellent comfort for the end user, significant energy savings and increased service life, the typical advantages of inverter controlled autoclave systems. E-SPD+ is an inverter that could be installed on the terminal box. It can be adapted on horizontal and vertical pumps. E-SPD+ can protect the system against overpressure, overcurrent, voltage fluctuation, dry run and water leak. The connection for this mode is made by communication line ON/OFF.

E-SPD+				
Power	Version	MT	TT	
	Power Voltage	Single-phase 230 V	Three-phase 400 V	
	Output Voltage (pump)	Three-phase 230 V	Three-phase 400 V	
	Output frequency	50 ÷ 60Hz		
	Maximum pump power	2.2 kW	4 kW	
	Max I in	20 A	12 A	
	Max I out	11 A	11 A	
Others	Pressure setpoint	0.5 ÷ 40 bar		
	Protection degree	IP 55		
	Ambient Temperature	-10 ÷ 40°C		
	Pressurisation units	2-3 pumps		
	Weight	2,7 Kg		
	Protection	Dry-running		
		Over/under voltage		
		Short-circuit		
Overload				
Overtemperature				
Pressure sensor fault				
Directives	2014/35/EU (LVD), 2014/30/EU (EMC), 2011/65/EU (RoHS II)			

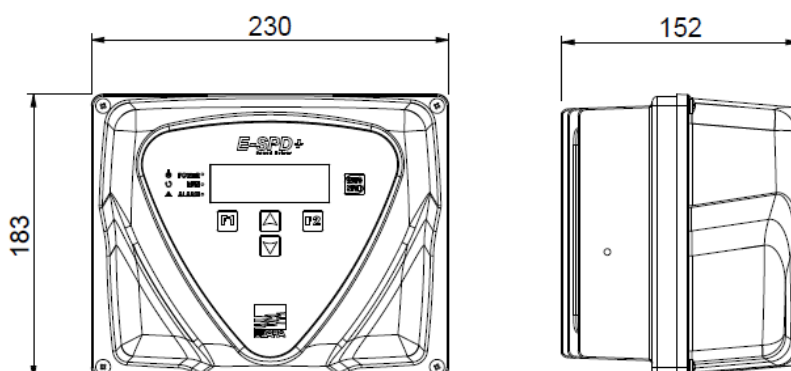

The dimensions may change without notice.

SP (EFC and MFC) SPECIFICATION

The control panels SP EFC/MFC series inverters modulate the operation of electropumps in response to control by the pressure transmitter (transducer measuring flow or other external signal 4-20 mA), regulating the speed of the electropumps to keep system demand constant. If the electronic controller or pressure transmitter fails, a system of pressure switches controls the pumps directly (if present).

VERSION

- “EFC”: Control panel for two or more electric pumps, with a single inverter with pump exchange
- “MFC”: Control panel for two or more electric pumps, with an inverter for each individual electropump

EFC / MFC		
Power	Power Voltage	Three-phase 400 V
	N° phases	Three phase without the use of neutral
	Frequence	50/60Hz
	Pump power	From 1.5kW up to 30kW
	Protection degree	IP55 up to 2.2kW IP44 3kW and above
	Ambient Temperature	-10°C + 40°C
	Pressurisation units	2 or 3 pumps
Directives	2014/35/EU (LVD), 2014/30/EU (EMC), 2011/65/EU (RoHS)	

Single inverter with exchange pump (SP EFC)

Panel type	Pump motor power (Three-phase)	Starting (Emergency / fixed speed pumps)	Option
2/3 pumps	1.5÷7.5 kW	Direct	Inverter pump Exchange
	11÷30kW	Star-Delta	

Multi-inverter: one inverter for each pump (SP MFC)

Panel type	Pump motor power (Three-phase)	Starting (Emergency / fixed speed pumps)
2/3 pumps	1.5 - 7,5 kW	Inverter ramp
	11 - 30 KW	Inverter ramp

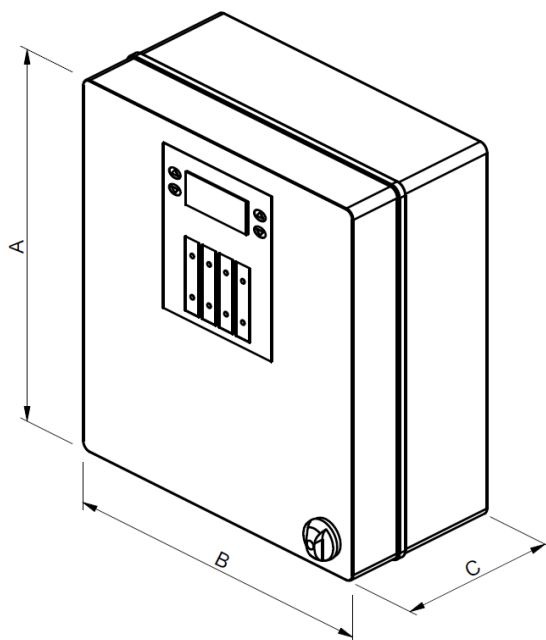

2SP EFC MODELS TABLE

Model	Motor power [kW]	Current [A]	Dimensions A-B-C [mm]	Weight [Kg]
2SP EFC 1,5T-2	2x1.5	2x3,7	450x400x200	25
2SP EFC 2,2T-2	2x2.2	2x5,3	450x400x200	25
2SP EFC 3T-2	2x3	2x7,2	450x400x250	25
2SP EFC 4T-2	2x4	2x9	450x400x250	25

The dimensions may change without notice.

2SP MFC MODELS TABLE

Model	Motor power [kW]	Current [A]	Dimensions A-B-C [mm]	Weight [Kg]
2SP EFC 1,5T-2	2x1.5	2x3.7	500x400x200	28
2SP EFC 2,2T-2	2x2.2	2x5.3	500x400x200	28
2SP EFC 3T-2	2x3	2x7.2	600x400x250	28
2SP EFC 4T-2	2x4	2x9	600x400x250	28

The dimensions may change without notice.

PROTECTION PANEL SPECIFICATION

Connection box for inverter :

- Connects the inverters with the power supply point.
- Equipped with circuit breakers on individual lines

Power source	Frequency	50/60 Hz	
	Phase	Single-phase	Three-phase
	Voltage	230 V ± 10%	400 V ± 10%
	Power	0.37 ÷ 3 kW	0.37 ÷ 15 kW
Others	Protection degree	IP 55	
	Ambient Temperature	-5°C + 40°C	
	Pressurisation units	2 pumps	
	Relative humidity	50% a 40°C MAX (90% a 20°C)	
	Max altitude	1000 m (a.s.l.)	
Directives	2014/35/EU (LVD), 2014/30/EU (EMC), 2011/65/EU (RoHS II)		

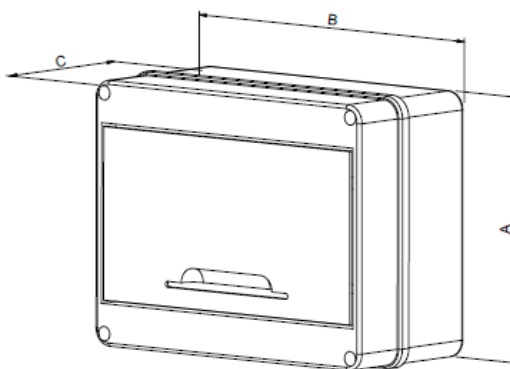

Model	N° Pumps	Power [kW]	Dimensions A-B-C [mm]	Max Current [A]
PROT.IP65 2P. 3M 20A NJ	2	2x3	160x200x90	2x20
PROT.IP65 2P. 4T 16A J		2x4	200x250x110	2x16

The dimensions may change without notice.



EBARA Pumps Europe S.p.A.

Via Torri di Confine 2/1 int. C
36053 Gambellara (Vicenza),
Italia Tel.: +39 0444 706811
Fax: +39 0444 405811
ebarapumps.epe@ebaracom
www.ebaraeurope.com

EBARA Corporation

11-1, Haneda Asahi-cho, Ota-ku,
Tokyo 144-8510
Japan
Tel. +81 3 6275 7598
Fax +81 3 5736 3193
www.ebara.com

