



Inverter controlled units with two vertical multistage pumps with stainless steel hydraulic parts.

PUMP FEATURES

FIELD OF USE

- Maximum working pressure: 10 bar
- Maximum temperature of the liquid: 90°C

MATERIALS

- Cast iron pump body
- External casing, impellers, intermediate stage, seal housing disc and shaft in AISI 304
- Mechanical seal in Carbon/Ceramic/NBR

TECHNICAL DATA

- T.E.F.C. 2 pole motor
- Class of insulation F
- IP55 Protection rating
- 230V $\pm 10\%$, 50Hz single phase voltage, 230/400V $\pm 10\%$, 50Hz three phase voltage
- Permanent capacitor inserted and thermo-amperometric protection with automatic reset incorporated for the single phase motor
- Circuit breaker protection under user's responsibility for the three phase version

TYPICAL APPLICATIONS

The base of the group is in galvanised steel as are the manifolds. The discharge manifold is set-up to gather any two vertical type membrane reservoirs. Two pressure switches, the electric control panel and a pressure gauge are mounted on it. On suction, each electric pump has an isolating valve and a non-return valve, with the possibility of connection to an air supply unit and has another isolating valve in discharge mode.

TECHNICAL FEATURES

The HERTZ TWIN control panel is an automatic control and protection system for two centrifugal pumps equipped with three phase induction motor. The control panel power supply can be three phase or single phase. The HERTZ TWIN control panels include a pump control software and allow regulation of motor speed via an electronic frequency changer (Inverter) that powers the pump motor. On varying the rotation speed, the pump performance varies in terms of flow rate and head, allowing optimal use in every condition and saving energy.

ADVANTAGES

- Energy saving because the controller modulates the pump according to the hydraulic energy request of the plant with respect to a direct connection in the network
- Improved and quicker regulation
- Hammering reduced thanks to gradual start-up and stop
- Improved comfort in the heating, air conditioning and pressure boosting systems
- Reduced peak current
- Exchange at every powered pump re-start
- Speed modulation on both pumps for excellent regulation

The typical applications of the GPE range pressure boosters with control panels are:

- Water provisioning for condominium, school, hotel hospital distribution networks etc.
- Water provisioning for industry in general
- Irrigation of gardens, parks and sports centres

2GPE HVM 3 range PERFORMANCE CURVES

(according to ISO 9906 Attachment A)

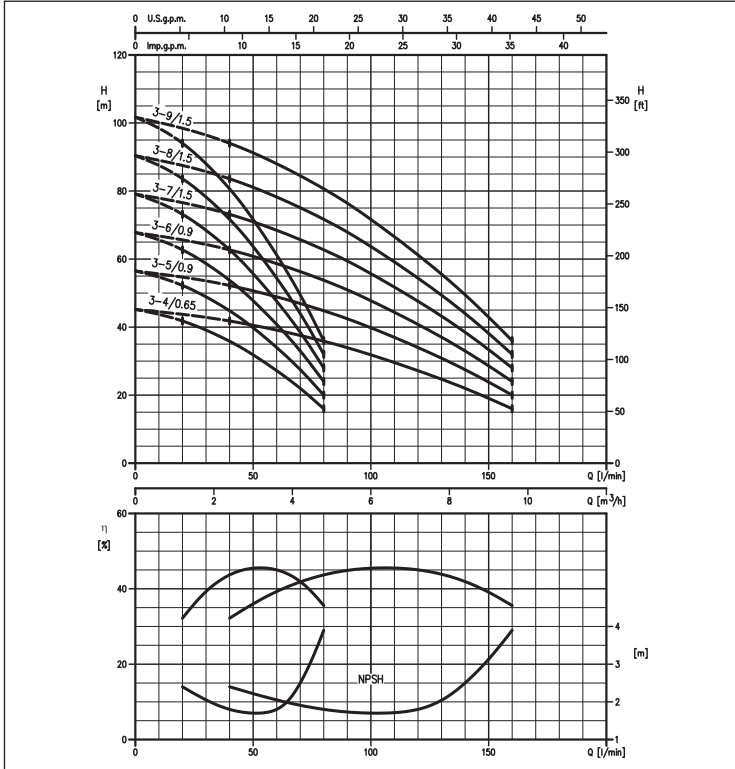

2GPE HVM 5 range PERFORMANCE CURVES

(according to ISO 9906 Attachment A)

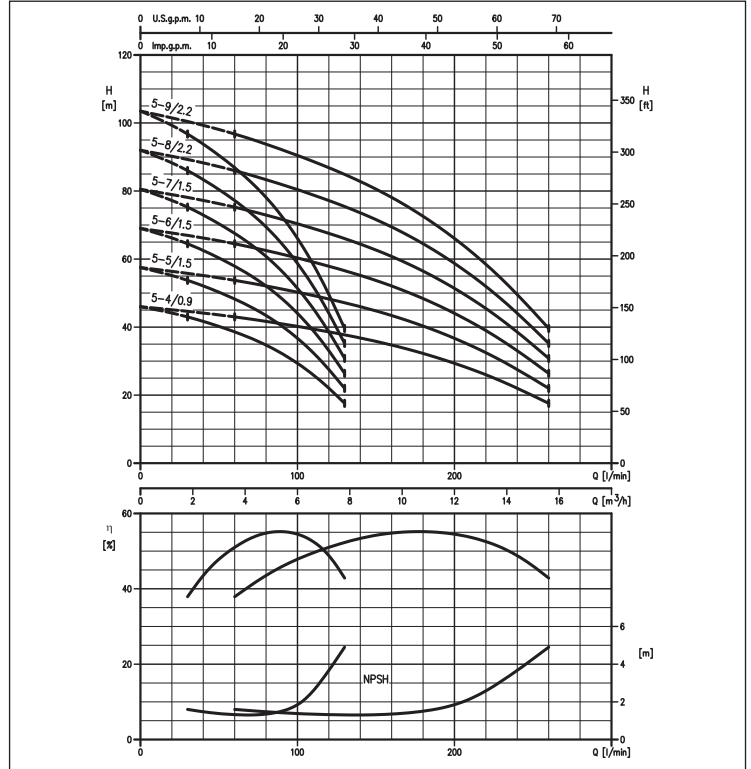

2GPE HVM A 10 range PERFORMANCE CURVES

(according to ISO 9906 Attachment A)

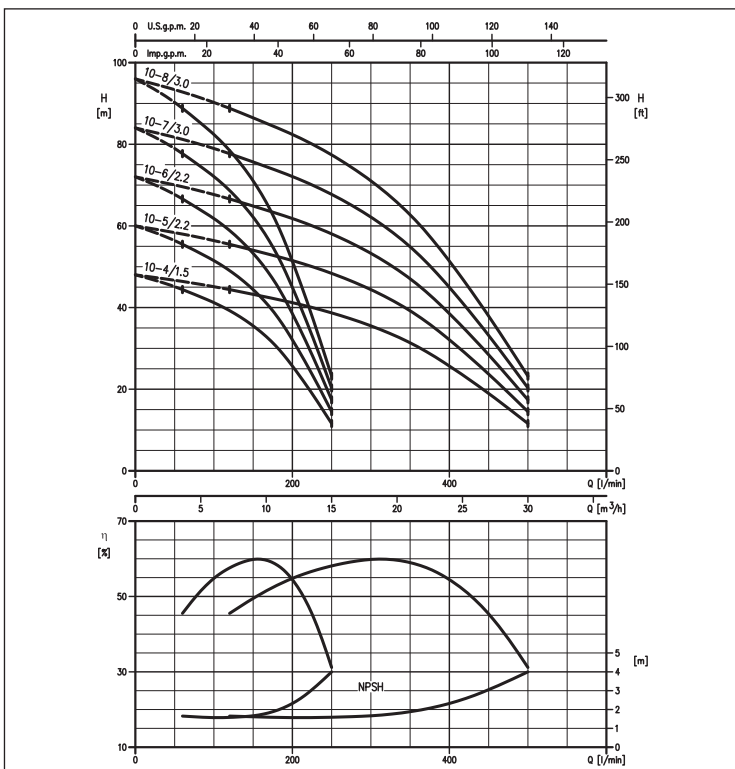

PERFORMANCE TABLE AND ELECTRIC DATA OF THE TWO PUMPS FUNCTIONING SIMULTANEOUSLY

Model	230V single phase	400V three-phase	[kW]	Max absorption [A]		Q=Flow rate									
				230V single phase	400V three-phase	l/min	40	60	90	120	160	200	260	320	400
						H=Head [m]									
						2,4	3,6	5,4	7,2	9,6	12	15,6	19,2	24	30
HVM 3-5N/0.9M	HVM 3-5N/0.9	0,9+0,9	11,4	5,2	52,5	49,0	42,5	34,0	20,0	-	-	-	-	-	-
HVM 3-6N/0.9M	HVM 3-6N/0.9	0,9+0,9	11,4	5,2	62,5	58,5	51,0	41,0	24,0	-	-	-	-	-	-
HVM 3-7N/1.5M	HVM 3-7N/1.5	1,5+1,5	17,4	6,8	73,0	68,5	59,5	47,5	28,0	-	-	-	-	-	-
HVM 3-8N/1.5M	HVM 3-8N/1.5	1,5+1,5	17,4	6,8	83,5	78,0	68,0	54,5	32,0	-	-	-	-	-	-
HVM 3-9N/1.5M	HVM 3-9N/1.5	1,5+1,5	17,4	6,8	94,0	88,0	76,5	61,0	36,0	-	-	-	-	-	-
HVM 5-6N/1.5M	HVM 5-6N/1.5	1,5+1,5	17,4	6,8	-	64,5	61,5	58,0	52,0	44,0	26,4	-	-	-	-
HVM 5-7N/1.5M	HVM 5-7N/1.5	1,5+1,5	17,4	6,8	-	75,5	71,5	67,5	61,0	51,5	30,8	-	-	-	-
HVM 5-8N/2.2M	HVM 5-8N/2.2	2,2+2,2	26	9,2	-	86,0	82,0	77,0	69,5	58,5	35,2	-	-	-	-
HVM 5-9N/2.2M	HVM 5-9N/2.2	2,2+2,2	26	9,2	-	97,0	92,0	87,0	78,0	66,0	39,6	-	-	-	-
HVM 10-4N/1.5M	HVM 10-4N/1.5	1,5+1,5	17,4	6,8	-	-	-	44,5	43,0	41,0	38,1	34,0	25,7	11,6	
HVM 10-5N/2.2M	HVM 10-5N/2.2	2,2+2,2	26	9,2	-	-	-	55,5	53,5	51,5	47,5	42,5	32,1	14,5	
HVM 10-6N/2.2M	HVM 10-6N/2.2	2,2+2,2	26	9,2	-	-	-	66,5	64,5	62,0	57,0	51,0	38,5	17,4	
-	HVM 10-7N/3	3+3	-	12,6	-	-	-	77,5	75,0	72,0	66,5	59,5	45,0	20,3	
-	HVM 10-8N/3	3+3	-	12,6	-	-	-	89,0	85,5	82,5	76,0	68,0	51,5	23,2	

DIMENSIONS

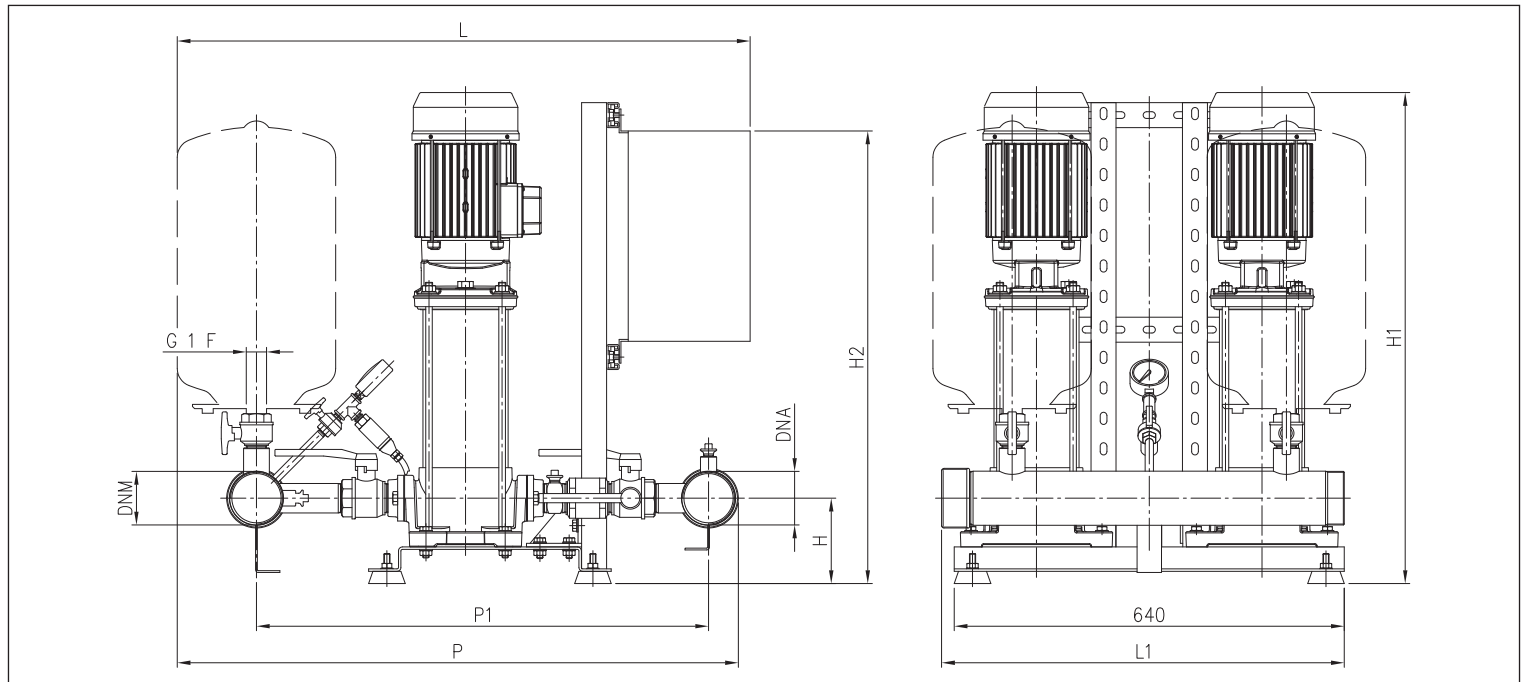

DIMENSIONS TABLE

Model	Dimensions [mm]										Weight [kg]		
	MT	L	TT	H	H1	MT	H2	TT	P	P1	L1	DNA-DNM	MT
2GPE HVM 3-5/0.9 TWIN	885	900	110	570	745	745	860	695	660	G2	102,0	104,0	
2GPE HVM 3-6/0.9 TWIN	885	900	110	595	745	745	860	695	660	G2	104,0	106,0	
2GPE HVM 3-7/1.5 TWIN	885	900	110	655	745	745	860	695	660	G2	110,0	112,0	
2GPE HVM 3-8/1.5 TWIN	885	900	110	680	745	745	860	695	660	G2	111,0	113,0	
2GPE HVM 3-9/1.5 TWIN	885	900	110	705	745	745	860	695	660	G2	113,0	115,0	
2GPE HVM 5-6/1.5 TWIN	855	870	110	635	745	745	800	635	660	G2	109,0	111,0	
2GPE HVM 5-7/1.5 TWIN	855	870	110	655	745	745	800	635	660	G2	111,0	113,0	
2GPE HVM 5-8/2.2 TWIN	-	870	110	695	745	745	800	635	660	G2	-	117,0	
2GPE HVM 5-9/2.2 TWIN	-	870	110	720	745	745	800	635	660	G2	-	117,0	
2GPE HVM 10-4/1.5 TWIN	-	910	140	640	745	745	920	740	670	G3	-	119,0	
2GPE HVM 10-5/2.2 TWIN	-	910	140	680	745	745	920	740	670	G3	-	124,0	
2GPE HVM 10-6/2.2 TWIN	-	910	140	710	745	745	920	740	670	G3	-	125,0	
2GPE HVM 10-7/3.0 TWIN	-	940	140	775	745	745	920	740	670	G3	-	133,0	
2GPE HVM 10-8/3.0 TWIN	-	940	140	805	745	745	920	740	670	G3	-	135,0	