



Inverter-controlled units with two horizontal multistage pumps with stainless steel hydraulic parts.

PUMP FEATURES

FIELD OF USE

- Maximum temperature of the liquid: 110°C
- Maximum working pressure: 10 bar
- Maximum chlorine content: 500 ppm

MATERIALS

- Pump body, impeller, intermediate body, and seal housing disc and shaft in AISI 304
- Mechanical sealing in Carbon/Ceramic/EPDM
- Support and motor casing in aluminium

TECHNICAL DATA

- Self-ventilated 2 pole asynchronous motor
- Class of insulation F
- IP55 Protection rating
- 230V $\pm 10\%$, 50Hz single phase voltage, 230/400V $\pm 10\%$, 50Hz three phase voltage
- Permanent capacitor inserted and thermo-amperometric protection with automatic reset incorporated for the single phase motor

TYPICAL APPLICATIONS

The base of the group is in galvanised steel as are the manifolds. The discharge manifold is set-up to gather any two vertical type membrane reservoirs; two pressure switches, the electric control panel and a pressure gauge are mounted on it. On inlet, each electric pump has an isolating valve and a non-return valve, with the possibility of connection to an air supply unit and has another isolating valve in discharge mode.

TECHNICAL FEATURES

The HERTZ TWIN control panel is an automatic control and protection system for two centrifugal pumps equipped with three phase induction motor. The control panel power supply can be three phase or single phase. The HERTZ TWIN control panels include a pump control software and allow regulation of motor speed via an electronic frequency changer (Inverter) that powers the pump motor. On varying the rotation speed, the pump performance varies in terms of flow rate and head, allowing optimal use in every condition and saving energy.

ADVANTAGES

- Energy saving because the controller modulates the pump according to the hydraulic energy request of the plant with respect to a direct connection in the network
- Improved and quicker regulation
- Hammering reduced thanks to gradual start-up and stop
- Improved comfort in the heating, air conditioning and pressure boosting systems
- Reduced peak current
- Exchange at every powered pump re-start
- Speed modulation on both pumps for excellent regulation

The typical applications of the GPE range pressure boosters with control panels are:

- Water provisioning for condominium, school, hotel hospital distribution networks etc.
- Water provisioning for industry in general
- Irrigation of gardens, parks and sports centres

2GPE MATRIX 3 range PERFORMANCE CURVES

(according to ISO 9906 Attachment A)

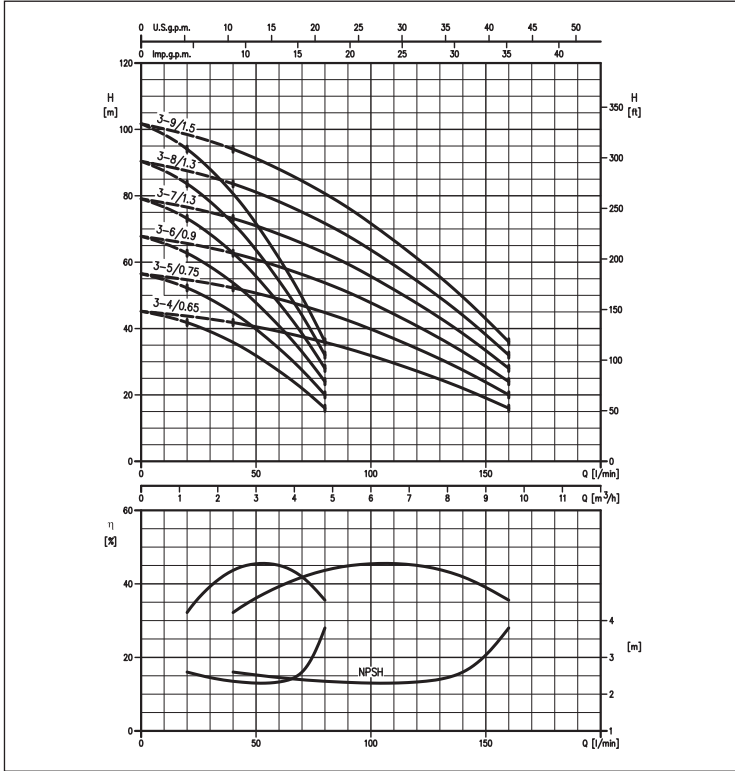

2GPE MATRIX 5 range PERFORMANCE CURVES

(according to ISO 9906 Attachment A)

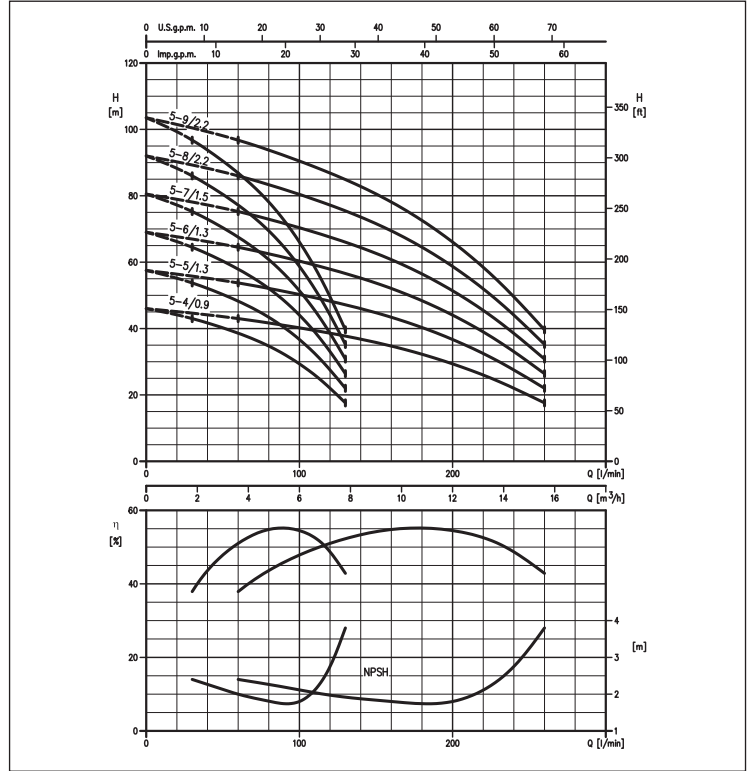

2GPE MATRIX 10 range PERFORMANCE CURVES

(according to ISO 9906 Attachment A)

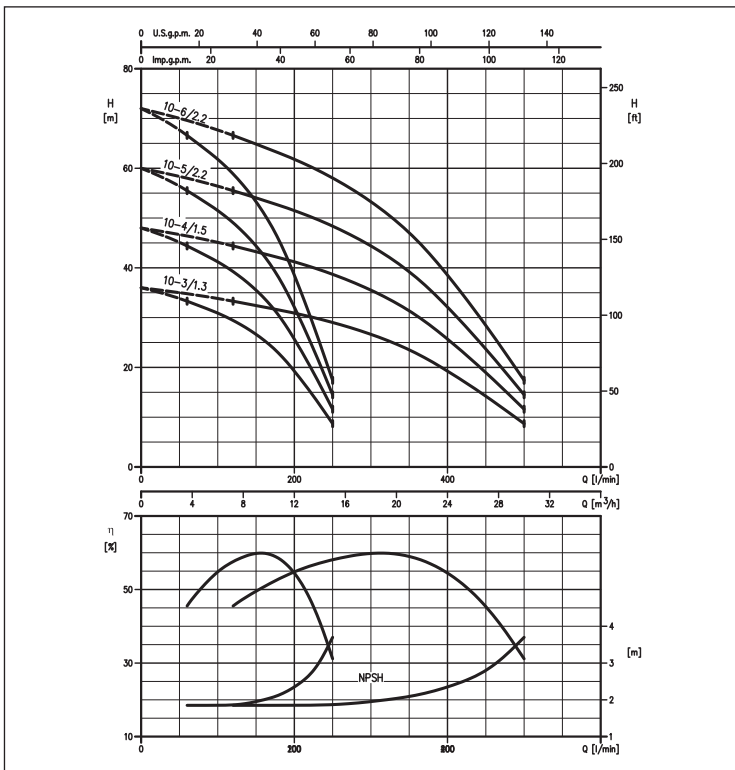

2GPE MATRIX 18 range PERFORMANCE CURVES

(according to ISO 9906 Attachment A)

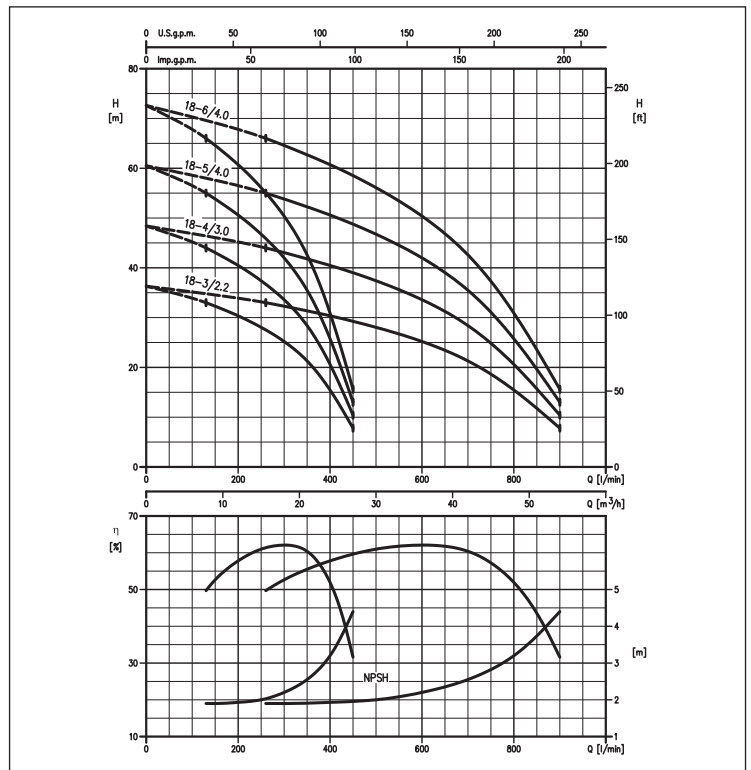

PERFORMANCE TABLE AND ELECTRIC DATA OF THE TWO PUMPS FUNCTIONING SIMULTANEOUSLY

Model		[kW]	Max absorption [A]		Q=Flow rate																
230V single phase	400V three-phase		230V single phase	400V three-phase	l/min	40	60	120	160	200	260	320	400	500	600	700	800	900			
						m ³ /h	2,4	3,6	7,2	9,6	12	15,6	19,2	24	30	36	42	48	54		
						H=Head [m]															
MATRIX 3-4/0.65M	MATRIX 3-4/0.65	0,65+0,65	9	3,2	42,0	39,1	27,2	16,0	-	-	-	-	-	-	-	-	-	-	-	-	
MATRIX 3-5/0.75M	MATRIX 3-5/0.75	0,75+0,75	10,8	5	52,5	49,0	34,0	20,0	-	-	-	-	-	-	-	-	-	-	-	-	
MATRIX 3-6/0.9M	MATRIX 3-6/0.9	0,9+0,9	11,4	5,2	62,5	58,5	41,0	24,0	-	-	-	-	-	-	-	-	-	-	-	-	
MATRIX 3-7/1.3M	MATRIX 3-7/1.3	1,3+1,3	15,6	7	73,0	68,5	47,5	28,0	-	-	-	-	-	-	-	-	-	-	-	-	
MATRIX 3-8/1.3M	MATRIX 3-8/1.3	1,3+1,3	15,6	7	83,5	78,0	54,5	32,0	-	-	-	-	-	-	-	-	-	-	-	-	
MATRIX 3-9/1.5M	MATRIX 3-9/1.5	1,5+1,5	17,4	6,8	94,0	88,0	61,0	36,0	-	-	-	-	-	-	-	-	-	-	-	-	
MATRIX 5-4/0.9M	MATRIX 5-4/0.9	0,9+0,9	11,4	5,2	-	43,0	38,6	34,7	29,4	17,6	-	-	-	-	-	-	-	-	-	-	
MATRIX 5-5/1.3M	MATRIX 5-5/1.3	1,3+1,3	15,6	7	-	54,0	48,5	43,5	36,7	22,0	-	-	-	-	-	-	-	-	-	-	
MATRIX 5-6/1.3M	MATRIX 5-6/1.3	1,3+1,3	15,6	7	-	64,5	58,0	52,0	44,0	26,4	-	-	-	-	-	-	-	-	-	-	
MATRIX 5-7/1.5M	MATRIX 5-7/1.5	1,5+1,5	17,4	6,8	-	75,5	67,5	61,0	51,5	30,8	-	-	-	-	-	-	-	-	-	-	
MATRIX 5-8/2.2M	MATRIX 5-8/2.2	2,2+2,2	26	9,2	-	86,0	77,0	69,5	58,5	35,2	-	-	-	-	-	-	-	-	-	-	
MATRIX 5-9/2.2M	MATRIX 5-9/2.2	2,2+2,2	26	9,2	-	97,0	87,0	78,0	66,0	39,6	-	-	-	-	-	-	-	-	-	-	
-	MATRIX 10-4/1.5	1,5+1,5	17,4	6,8	-	-	44,5	43,0	41,0	38,1	34,0	25,7	11,6	-	-	-	-	-	-	-	
-	MATRIX 10-5/2.2	2,2+2,2	26	9,2	-	-	55,5	53,5	51,5	47,5	42,5	32,1	14,5	-	-	-	-	-	-	-	
-	MATRIX 10-6/2.2	2,2+2,2	26	9,2	-	-	66,5	64,5	62,0	57,0	51,0	38,5	17,4	-	-	-	-	-	-	-	
-	MATRIX 18-4/3.0	3+3	-	12,6	-	-	-	-	-	44,0	42,5	40,5	37,4	33,6	28,4	20,6	10,4	-	-	-	
-	MATRIX 18-5/4.0	4+4	-	16,2	-	-	-	-	-	55,0	53,0	50,5	47,0	42,0	35,5	25,8	13,0	-	-	-	
-	MATRIX 18-6/4.0	4+4	-	16,2	-	-	-	-	-	66,0	64,0	60,5	56,0	50,5	42,5	30,9	15,6	-	-	-	

DIMENSIONS

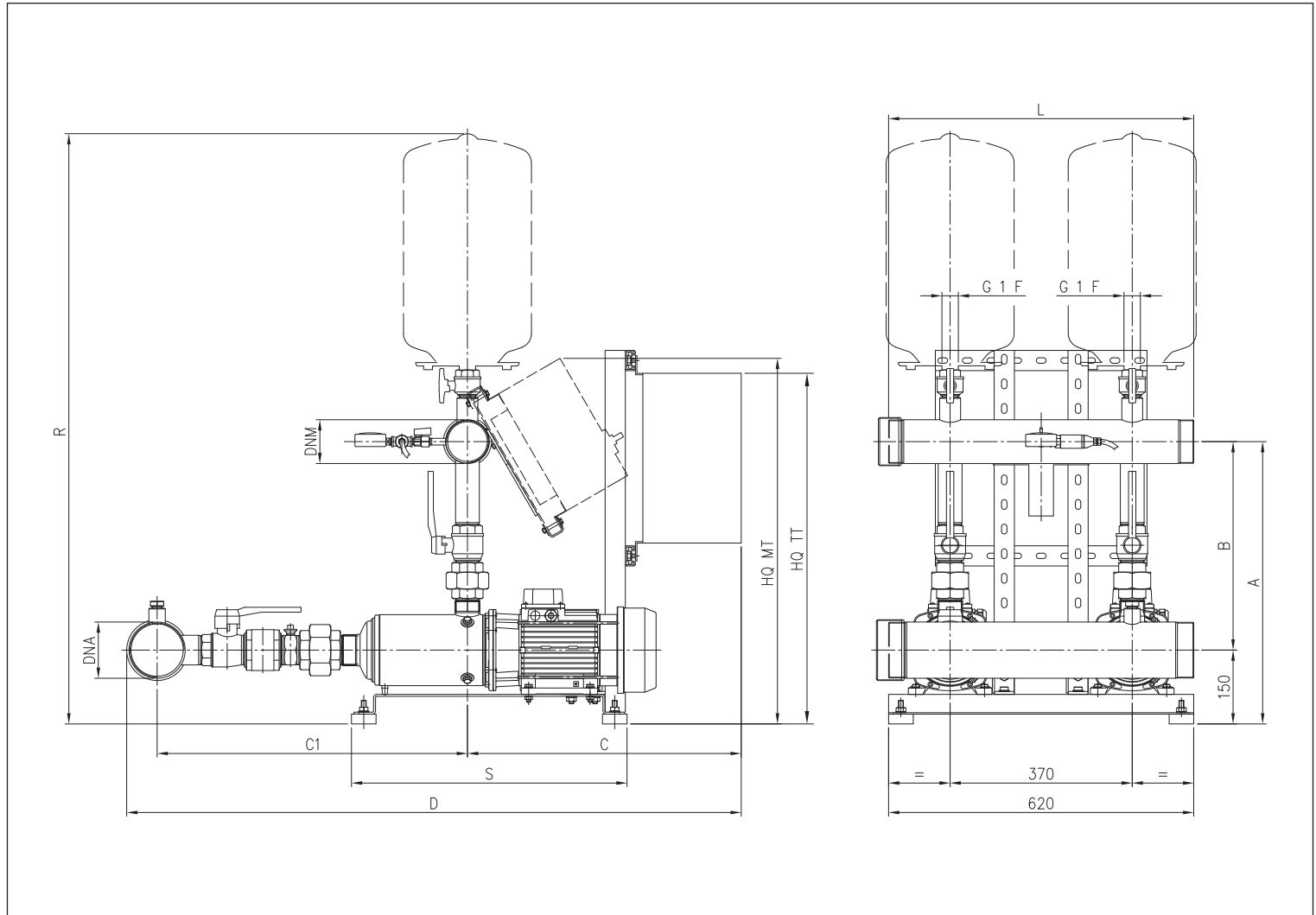

DIMENSIONS TABLE

Model	Dimensions [mm]																Weight [kg]	
	A	B	MT	TT	C1	MT	TT	DNA	DNM	HQ	TT	L	R	MT	TT	MT	TT	
2GPE MATRIX 3-4T/0,65 TWIN	490	340	305	495	450	795	980	50	40	650	670	520	1100	380	550	69,0	82,0	
2GPE MATRIX 3-5T/0,75 TWIN	490	340	305	495	475	815	1000	50	40	650	670	520	1100	380	550	73,0	86,0	
2GPE MATRIX 3-6T/0,9 TWIN	490	340	305	495	500	840	980	50	40	650	670	520	1100	380	550	76,0	89,0	
2GPE MATRIX 3-7T/1,3 TWIN	490	340	305	495	520	865	1050	50	40	650	670	520	1100	550	550	83,0	89,0	
2GPE MATRIX 3-8T/1,3 TWIN	490	340	305	495	545	890	1075	50	40	650	670	520	1100	550	550	83,0	89,0	
2GPE MATRIX 3-9T/1,5 TWIN	490	340	305	495	570	910	1100	50	40	650	670	520	1100	550	550	87,0	93,0	
2GPE MATRIX 5-4T/0,9 TWIN	500	350	315	495	490	845	1025	65	50	660	670	520	1110	380	550	77,0	90,0	
2GPE MATRIX 5-5T/1,3 TWIN	500	350	315	495	515	870	1050	65	50	660	670	520	1110	380	550	82,0	95,0	
2GPE MATRIX 5-6T/1,3 TWIN	500	350	315	495	535	890	1075	65	50	660	670	520	1110	380	550	85,0	98,0	
2GPE MATRIX 5-7T/1,5 TWIN	500	350	315	495	560	915	1095	65	50	660	670	520	1110	550	550	90,0	96,0	
2GPE MATRIX 5-8T/2,2 TWIN	500	350	-	495	585	-	1120	65	50	-	670	520	1110	-	550	-	102,0	
2GPE MATRIX 5-9T/2,2 TWIN	500	350	-	495	610	-	1145	65	50	-	670	520	1110	-	550	-	102,0	
2GPE MATRIX 10-4T/1,5 TWIN	515	365	-	500	540	-	1085	80	65	-	670	520	1135	-	550	-	97,0	
2GPE MATRIX 10-5T/2,2 TWIN	515	365	-	500	570	-	1115	80	65	-	670	520	1135	-	550	-	102,0	
2GPE MATRIX 10-6T/2,2 TWIN	515	365	-	495	600	-	1145	80	65	-	670	520	1135	-	550	-	105,0	
2GPE MATRIX 18-4T/3,0 TWIN	575	425	-	555	555	-	1175	100	80	-	670	620	1200	-	550	-	122,0	
2GPE MATRIX 18-5T/3,8 TWIN	575	425	-	555	595	-	1175	100	80	-	670	620	1200	-	550	-	123,0	
2GPE MATRIX 18-6T/4,0 TWIN	575	425	-	555	630	-	1250	100	80	-	715	620	1200	-	550	-	135,0	