

6" SUBMERSED CENTRIFUGAL PUMPS

in AISI 304



Pumps submersed in stainless steel for 6" deep wells in AISI 304.

APPLICATIONS

- Water provisioning from deep wells
- Water supply and pressure boosting
- Irrigation systems
- Treating waters, filtering and reverse osmosis
- Industrial cooling systems
- Fountains and fire-fighting plants

TECHNICAL DETAILS

- The range includes: three models with radial discharge for high heads and medium flow rates and two models with semi-axial discharge for medium heads and high flow rates
- High resistance to corrosion
- Reliable
- Compact
- Also suitable for horizontal functioning

TECHNICAL DATA

- Maximum sand content: 50 ppm
 - Maximum temperature of the liquid: 50°C
- The pump and the motor are supplied separately.**

- 2 pole motor in bath of liquid refrigerant (OY) or in water bath (WY),
- Protection rating IP58 (OY), IP68 (WY)
- 380V -10% 50 Hz three phase voltage (OY)
- 400V +6% 50 Hz three phase voltage (OY)
- 380V -10% 50 Hz three phase voltage (WY)
- 415V +6% 50 Hz three phase voltage (WY)
- Class of insulation F (4" - -6" OY version)
 (6" WY version)
 B (4" WY version)
- L version in AISI 316 stainless steel available on request
- Motor support for coupling to 4" motors
- For cable dimensioning (see page 41)

MATERIALS

- Entirely in stainless steel
- Wear ring in PTFE
- Shaft guide support in ceramic

CONTROL PANELS

- Q Series (see page 42)
- 1EPBH (see page 43)

ACCESSORIES (on request)

- Cable for motor 6" WY6 - 4x4 - 4 m
- Cable for motor 6" WY6 - 4x4 - 8 m
- Junction for cable GPS-2 (for 4x1.5 and 4x2.5 cables)
- Casting resin cable junction 92A1 (section 1.5÷10 mm²)
- Casting resin cable junction 92A2 (section 4÷25 mm²)
- PVC 5m key float with counter-weight
- PVC 10 m key float with counter-weight
- PVC 20 m key float with counter-weight
- Capacitor MF 70,450V L=150
- Capacitor MF 80,450V L=150

PERFORMANCE RANGE (according to ISO 9906 Attachment A)

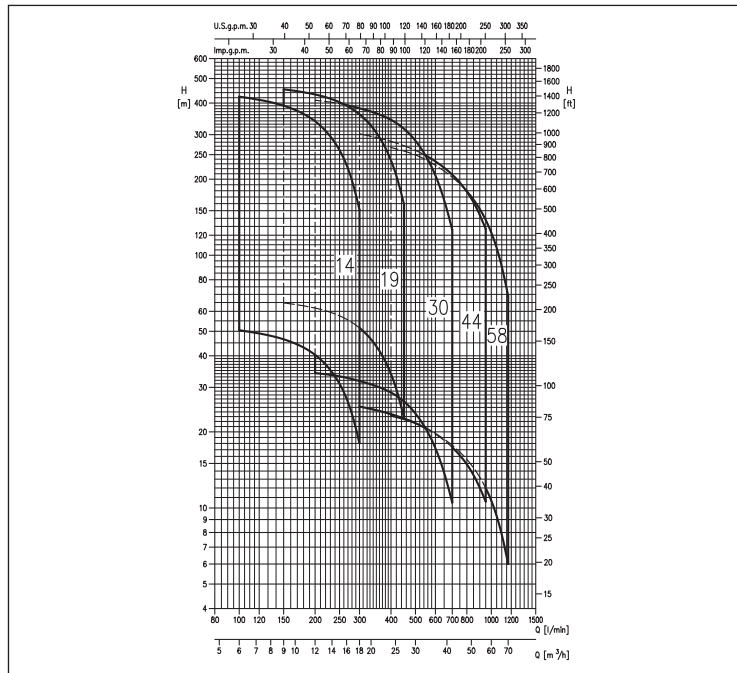

IDENTIFICATION CODE

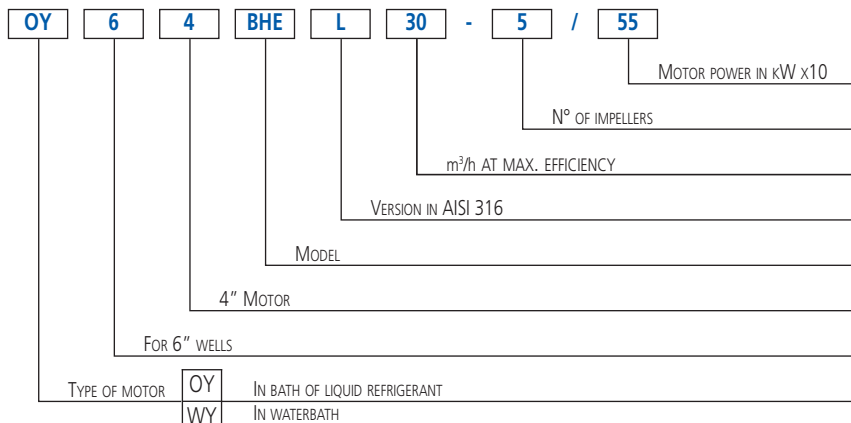

6" SUBMERSED CENTRIFUGAL PUMPS

in AISI 304

PERFORMANCE TABLE

Model	Motor size	P ₂		Q=Flow rate														
		[HP]	[kW]	l/min m ³ /h	100	150	200	250	300	400	450	525	600	700	825	950	1050	1167
					6	9	12	15	18	24	27	31,5	36	42	49,5	57	63	70
				H=Head [m]														
64 BHE 14 - 5	4"	3	2,2	50,5	46,5	40,5	31	18	-	-	-	-	-	-	-	-	-	
64 BHE 14 - 8	4"	5,5	4	81	74,5	64,5	49,5	28,8	-	-	-	-	-	-	-	-	-	
6 BHE 14 - 8	6"	5,5	4	81	74,5	64,5	49,5	28,8	-	-	-	-	-	-	-	-	-	
64 BHE 14 - 13	4"	7,5	5,5	131	121	105	80,5	47	-	-	-	-	-	-	-	-	-	
6 BHE 14 - 13	6"	7,5	5,5	131	121	105	80,5	47	-	-	-	-	-	-	-	-	-	
6 BHE 14 - 17	6"	10	7,5	172	158	137	105	61	-	-	-	-	-	-	-	-	-	
6 BHE 14 - 22	6"	12,5	9,2	222	205	178	136	79	-	-	-	-	-	-	-	-	-	
6 BHE 14 - 26	6"	15	11	263	242	210	161	93,5	-	-	-	-	-	-	-	-	-	
6 BHE 14 - 32	6"	20	15	323	298	258	198	115	-	-	-	-	-	-	-	-	-	
6 BHE 14 - 36	6"	20	15	364	335	291	223	130	-	-	-	-	-	-	-	-	-	
6 BHE 14 - 42	6"	25	18,5	424	391	339	260	151	-	-	-	-	-	-	-	-	-	
64 BHE 19 - 6	4"	5,5	4	-	65	62	57,5	51,5	33,9	22,8	-	-	-	-	-	-	-	
6 BHE 19 - 6	6"	5,5	4	-	65	62	57,5	51,5	33,9	22,8	-	-	-	-	-	-	-	
64 BHE 19 - 9	4"	7,5	5,5	-	97	92,5	86,5	77,5	51	34,2	-	-	-	-	-	-	-	
6 BHE 19 - 9	6"	7,5	5,5	-	97	92,5	86,5	77,5	51	34,2	-	-	-	-	-	-	-	
6 BHE 19 - 12	6"	10	7,5	-	130	124	115	103	68	45,5	-	-	-	-	-	-	-	
6 BHE 19 - 15	6"	12,5	9,2	-	162	155	144	129	85	57	-	-	-	-	-	-	-	
6 BHE 19 - 18	6"	15	11	-	194	185	173	155	102	68,5	-	-	-	-	-	-	-	
6 BHE 19 - 21	6"	20	15	-	227	216	202	181	119	80	-	-	-	-	-	-	-	
6 BHE 19 - 24	6"	20	15	-	259	247	230	206	136	91	-	-	-	-	-	-	-	
6 BHE 19 - 28	6"	25	18,5	-	302	288	269	241	158	106	-	-	-	-	-	-	-	
6 BHE 19 - 30	6"	25	18,5	-	324	309	288	258	170	114	-	-	-	-	-	-	-	
6 BHE 19 - 33	6"	30	22	-	356	340	317	284	186	125	-	-	-	-	-	-	-	
6 BHE 19 - 36	6"	30	22	-	389	371	346	310	203	137	-	-	-	-	-	-	-	
6 BHE 19 - 39	6"	40	30	-	421	402	374	335	220	148	-	-	-	-	-	-	-	
6 BHE 19 - 42	6"	40	30	-	454	433	403	361	237	160	-	-	-	-	-	-	-	
64 BHE 30 - 3	4"	4	3	-	-	34,2	33,2	31,8	28,6	26,4	22,1	17,3	10,5	-	-	-	-	
64 BHE 30 - 4	4"	5,5	4	-	-	45,5	44	42,5	38,2	35,2	29,5	23	14	-	-	-	-	
6 BHE 30 - 4	6"	5,5	4	-	-	45,5	44	42,5	38,2	35,2	29,5	23	14	-	-	-	-	
64 BHE 30 - 5	4"	7,5	5,5	-	-	57	55,5	53	47,5	44	36,9	28,8	17,5	-	-	-	-	
6 BHE 30 - 5	6"	7,5	5,5	-	-	57	55,5	53	47,5	44	36,9	28,8	17,5	-	-	-	-	
6 BHE 30 - 7	6"	10	7,5	-	-	80	77,5	74	67	61,5	51,5	40,5	24,5	-	-	-	-	
6 BHE 30 - 11	6"	15	11	-	-	125	122	117	105	97	81	63,5	38,5	-	-	-	-	
6 BHE 30 - 15	6"	20	15	-	-	171	166	159	143	132	111	86,5	52,5	-	-	-	-	
6 BHE 30 - 19	6"	25	18,5	-	-	217	210	201	181	167	140	109	66,5	-	-	-	-	
6 BHE 30 - 23	6"	30	22	-	-	262	254	244	219	202	170	132	80,5	-	-	-	-	
6 BHE 30 - 27	6"	40	30	-	-	308	299	286	258	238	199	155	94,5	-	-	-	-	
6 BHE 30 - 31	6"	40	30	-	-	353	343	329	296	273	229	178	109	-	-	-	-	
6 BHE 30 - 33	6"	50	37	-	-	376	365	350	315	290	244	190	116	-	-	-	-	
6 BHE 30 - 36	6"	50	37	-	-	410	398	382	343	317	266	207	126	-	-	-	-	
64 BHE 44 - 2	4"	4	3	-	-	-	-	25,2	23,5	22,6	21,2	19,6	17,4	14,2	10,6	-	-	
64 BHE 44 - 3	4"	7,5	5,5	-	-	-	-	37,8	35,3	33,9	31,7	29,4	26	21,3	15,9	-	-	
6 BHE 44 - 3	6"	7,5	5,5	-	-	-	-	37,8	35,3	33,9	31,7	29,4	26	21,3	15,9	-	-	
6 BHE 44 - 5	6"	10	7,5	-	-	-	-	63	59	56,5	53	49	43,5	35,5	26,5	-	-	
6 BHE 44 - 7	6"	15	11	-	-	-	-	88	82,5	79	74	68,5	61	49,5	37,1	-	-	
6 BHE 44 - 9	6"	20	15	-	-	-	-	113	106	102	95	88	78	64	47,5	-	-	
6 BHE 44 - 10	6"	20	15	-	-	-	-	126	118	113	106	98	87	71	53	-	-	
6 BHE 44 - 12	6"	25	18,5	-	-	-	-	151	141	136	127	118	104	85	63,5	-	-	
6 BHE 44 - 15	6"	30	22	-	-	-	-	189	176	170	159	147	130	107	79,5	-	-	
6 BHE 44 - 18	6"	40	30	-	-	-	-	227	212	203	190	176	156	128	95,5	-	-	
6 BHE 44 - 20	6"	40	30	-	-	-	-	252	235	226	212	196	174	142	106	-	-	
6 BHE 44 - 22	6"	50	37	-	-	-	-	277	259	249	233	216	191	156	117	-	-	
6 BHE 44 - 24	6"	50	37	-	-	-	-	302	282	271	254	235	208	170	127	-	-	
64 BHE 58 - 2	4"	4	3	-	-	-	-	-	23,2	22,5	21,2	19,7	17,7	15	12	9,3	6	
64 BHE 58 - 3	4"	7,5	5,5	-	-	-	-	-	34,8	33,7	31,9	29,6	26,6	22,5	18	14	9	
6 BHE 58 - 3	6"	7,5	5,5	-	-	-	-	-	34,8	33,7	31,9	29,6	26,6	22,5	18	14	9	
6 BHE 58 - 5	6"	10	7,5	-	-	-	-	-	58	56	53	49,5	44,5	37,5	30	23,3	15	
6 BHE 58 - 7	6"	15	11	-	-	-	-	-	81	78,5	74,5	69	62	52,5	42	32,6	21	
6 BHE 58 - 9	6"	20	15	-	-	-	-	-	104	101	95,5	89	79,5	67,5	54	42	27	
6 BHE 58 - 10	6"	20	15	-	-	-	-	-	116	112	106	98,5	88,5	75	60	46,5	30	
6 BHE 58 - 12	6"	25	18,5	-	-	-	-	-	139	135	127	118	106	90	72	56	36	
6 BHE 58 - 14	6"	30	22	-	-	-	-	-	162	157	149	138	124	105	84	65	42	
6 BHE 58 - 16	6"	40	30	-	-	-	-	-	186	180	170	158	142	120	96	74,5	48	
6 BHE 58 - 18	6"	40	30	-	-	-	-	-	209	202	191	178	159	135	108	83,5	54	
6 BHE 58 - 20	6"	50	37	-	-	-	-	-	232	225	212	197	177	150	120	93	60	
6 BHE 58 - 23	6"	50	37	-	-	-	-	-	267	259	244	227	204	173	138	107	69	



6BHE

6" SUBMERSED CENTRIFUGAL PUMPS in AISI 304

6(4) BHE 14 range PERFORMANCE CURVES

(according to ISO 9906 Attachment A)

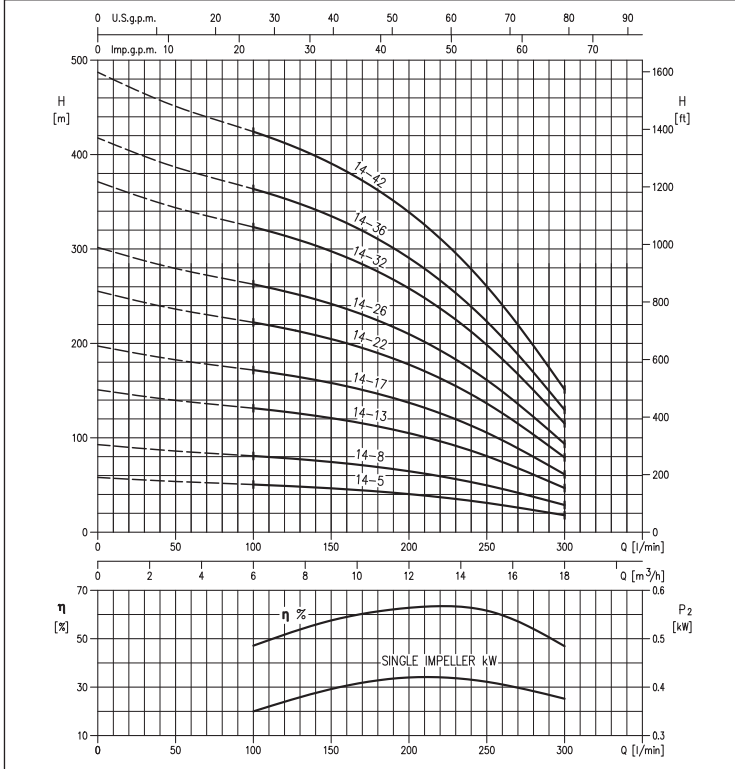

6(4)BHE 19 range PERFORMANCE CURVES

(according to ISO 9906 Attachment A)

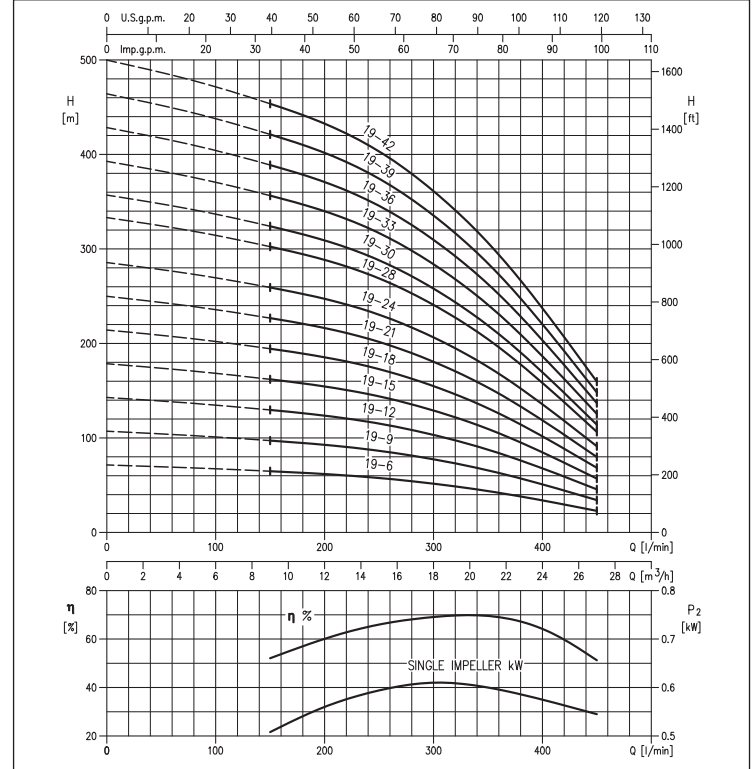

6(4)BHE 30 range PERFORMANCE CURVES

(according to ISO 9906 Attachment A)

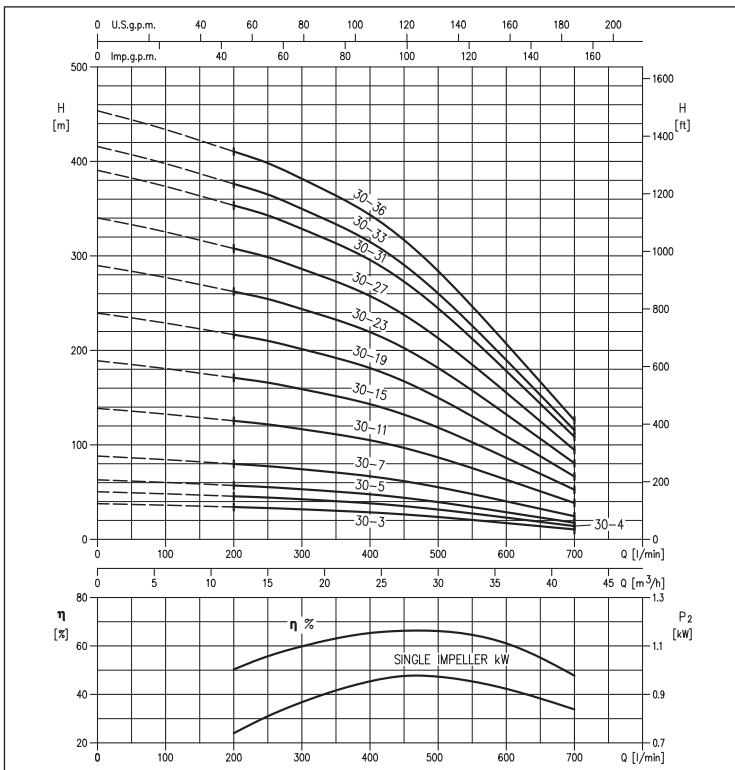

6(4)BHE 44 range PERFORMANCE CURVES

(according to ISO 9906 Attachment A)

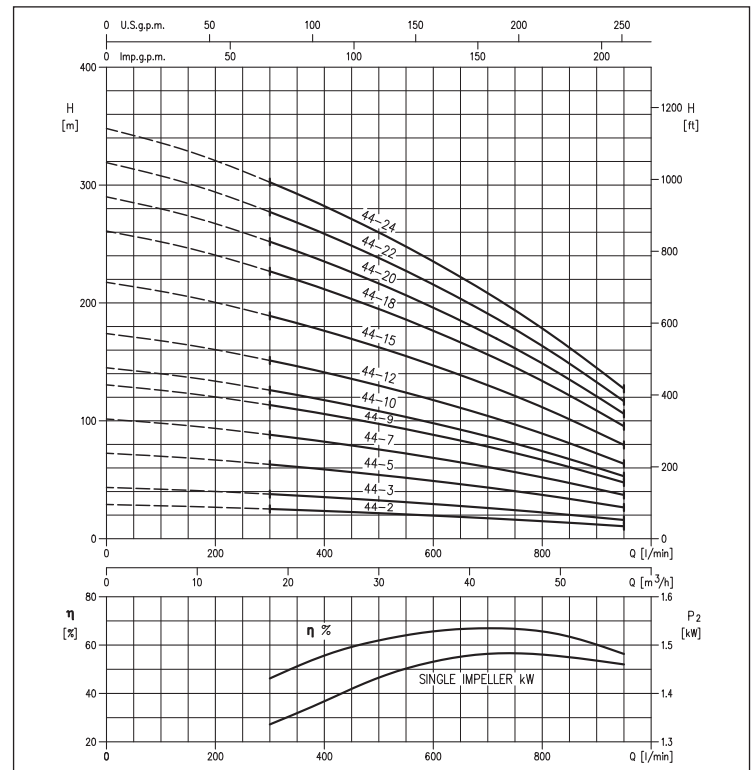

6BHE

6" SUBMERSED CENTRIFUGAL PUMPS in AISI 304

6(4)BHE 58 range PERFORMANCE CURVES

(according to ISO 9906 Attachment A)

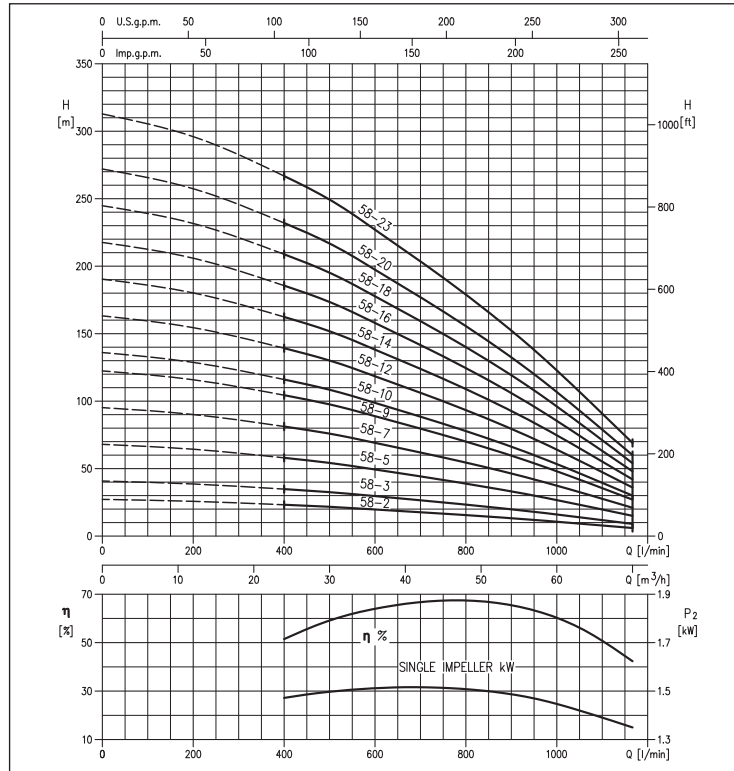

DIMENSIONS

Pump with 4" motor connection (64BHE)

Pump with 6" motor connection (6BHE)

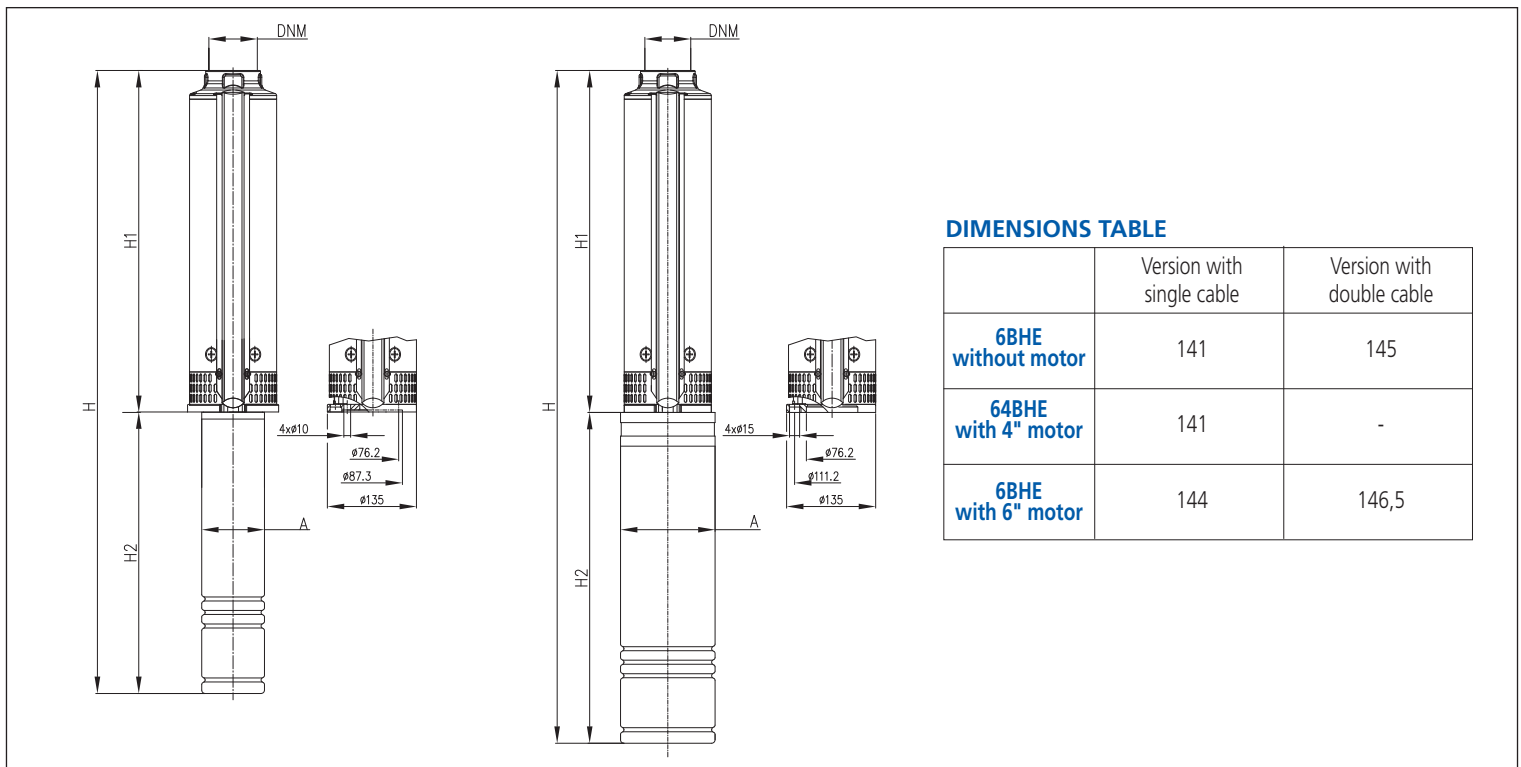

DIMENSIONS TABLE

	Version with single cable	Version with double cable
6BHE without motor	141	145
64BHE with 4" motor	141	-
6BHE with 6" motor	144	146,5

6" SUBMERSED CENTRIFUGAL PUMPS

in AISI 304

DIMENSIONS TABLE

Model	Motor size	P ₂		Pump without motor			Pump with motor in bath of liquid refrigerant				Pump with motor in water bath			
		[HP]	[kW]	H1 [mm]	DNM	Weight [kg]	A [mm]	H2 [mm]	H [mm]	Weight [kg]	A [mm]	H2 [mm]	H [mm]	Weight [kg]
64 BHE 14 - 5	4"	3	2,2	356	G2 ½	10,5	97	466	820	25	95	440	794	27
64 BHE 14 - 8	4"	5,5	4	446	G2 ½	13	97	574	1018	33	95	583	1027	37
6 BHE 14 - 8	6"	5,5	4	446	G2 ½	13	139	540	986	51	137	581	1027	51
64 BHE 14 - 13	4"	7,5	5,5	596	G2 ½	16,5	97	644	1238	39	95	698	1291	46
6 BHE 14 - 13	6"	7,5	5,5	596	G2 ½	16,5	139	570	1166	57	137	614	1210	58
6 BHE 14 - 17	6"	10	7,5	716	G2 ½	19,5	139	600	1316	62	137	646	1362	65
6 BHE 14 - 22	6"	12,5	9,2	866	G2 ½	23	139	600	1466	68	137	679	1545	71
6 BHE 14 - 26	6"	15	11	986	G2 ½	26	139	700	1686	74	137	711	1697	77
6 BHE 14 - 32	6"	20	15	1166	G2 ½	30,5	139	760	1926	85	137	776	1942	87
6 BHE 14 - 36	6"	20	15	1286	G2 ½	33,5	139	760	2046	88	137	776	2062	90
6 BHE 14 - 42	6"	25	18,5	1466	G2 ½	38	139	830	2296	103	137	842	2308	101
64 BHE 19 - 6	4"	5,5	4	431	G2 ½	12,0	97	574	1003	32	95	583	1012	36
6 BHE 19 - 6	6"	5,5	4	431	G2 ½	12,0	139	540	971	50	137	581	1012	50
64 BHE 19 - 9	4"	7,5	5,5	543,5	G2 ½	14,5	97	644	1185	37	95	698	1239	44
6 BHE 19 - 9	6"	7,5	5,5	543,5	G2 ½	14,5	139	570	1114	55	137	614	1158	56
6 BHE 19 - 12	6"	10	7,5	656	G2 ½	16,5	139	600	1256	59	137	646	1302	62
6 BHE 19 - 15	6"	12,5	9,2	768,5	G2 ½	19,0	139	600	1369	64	137	679	1447	67
6 BHE 19 - 18	6"	15	11	881	G2 ½	21,5	139	700	1581	70	137	711	1592	72
6 BHE 19 - 21	6"	20	15	993,5	G2 ½	24,0	139	760	1754	78	137	776	1770	81
6 BHE 19 - 24	6"	20	15	1106	G2 ½	26,5	139	760	1866	81	137	776	1882	83
6 BHE 19 - 28	6"	25	18,5	1256	G2 ½	30,0	139	830	2086	95	137	842	2098	93
6 BHE 19 - 30	6"	25	18,5	1331	G2 ½	31,5	139	830	2161	97	137	842	2173	95
6 BHE 19 - 33	6"	30	22	1443,5	G2 ½	34,0	139	890	2334	104	137	907	2350	103
6 BHE 19 - 36	6"	30	22	1556	G2 ½	36,5	139	890	2446	107	137	907	2463	106
6 BHE 19 - 39	6"	40	30	1668	G2 ½	39,0	139	1030	2698	129	137	1037	2705	123
6 BHE 19 - 42	6"	40	30	1853	G2 ½	42,0	139	1030	2883	132	137	1037	2890	126
64 BHE 30 - 3	4"	4	3	365,5	G3	10,5	97	544	907	30	95	507	870	30
64 BHE 30 - 4	4"	5,5	4	412	G3	11,5	97	574	984	32	95	583	993	36
6 BHE 30 - 4	6"	5,5	4	412	G3	11,5	139	540	952	50	137	581	993	49
64 BHE 30 - 5	4"	7,5	5,5	458,5	G3	12,5	97	644	1100	35	95	698	1154	42
6 BHE 30 - 5	6"	7,5	5,5	458,5	G3	12,5	139	570	1029	53	137	614	1073	54
6 BHE 30 - 7	6"	10	7,5	551,5	G3	14,5	139	600	1152	57	137	646	1198	60
6 BHE 30 - 11	6"	15	11	737,5	G3	18,5	139	700	1438	67	137	711	1449	69
6 BHE 30 - 15	6"	20	15	923,5	G3	22,5	139	700	1624	77	137	776	1700	79
6 BHE 30 - 19	6"	25	18,5	1109,5	G3	26,0	139	830	1940	91	137	842	1951	89
6 BHE 30 - 23	6"	30	22	1295,5	G3	30,0	139	890	2186	100	137	907	2202	99
6 BHE 30 - 27	6"	40	30	1481,5	G3	34,0	139	1030	2512	124	137	1037	2518	118
6 BHE 30 - 31	6"	40	30	1667,5	G3	38,0	139	1030	2698	128	137	1037	2704	122
6 BHE 30 - 33	6"	50	37	1760	G3	40,0	-	-	-	-	137	1405	3165	175
6 BHE 30 - 36	6"	50	37	1899,5	G3	43,0	-	-	-	-	137	1405	3304	178
64 BHE 44 - 2	4"	4	3	365,5	G3	11,0	97	544	907	30	95	507	870	30
64 BHE 44 - 3	4"	7,5	5,5	458,5	G3	13,5	97	644	1100	36	95	698	1154	43
6 BHE 44 - 3	6"	7,5	5,5	458,5	G3	13,5	139	570	1029	54	137	614	1073	55
6 BHE 44 - 5	6"	10	7,5	644,5	G3	18,0	139	600	1245	60	137	646	1291	63
6 BHE 44 - 7	6"	15	11	830,5	G3	22,5	139	700	1531	71	137	711	1542	73
6 BHE 44 - 9	6"	20	15	1016,5	G3	27,0	139	760	1777	81	137	776	1793	84
6 BHE 44 - 10	6"	20	15	1109,5	G3	29,5	139	760	1870	84	137	776	1886	86
6 BHE 44 - 12	6"	25	18,5	1295,5	G3	34,0	139	830	2126	99	137	842	2137	97
6 BHE 44 - 15	6"	30	22	1574,5	G3	40,5	139	890	2465	111	137	907	2481	110
6 BHE 44 - 18	6"	40	30	1853,5	G3	47,5	139	1030	2884	138	137	1037	2890	131
6 BHE 44 - 20	6"	40	30	2039,5	G3	52,0	139	1030	3070	142	137	1037	3076	136
6 BHE 44 - 22	6"	50	37	2225,5	G3	56,5	-	-	-	-	137	1405	3630	192
6 BHE 44 - 24	6"	50	37	2411	G3	61,0	-	-	-	-	137	1405	3816	196
64 BHE 58 - 2	4"	4	3	365,5	G3	11,5	97	544	907	31	95	507	870	31
64 BHE 58 - 3	4"	7,5	5,5	458,5	G3	13,5	97	644	1100	36	95	698	1154	43
6 BHE 58 - 3	6"	7,5	5,5	458,5	G3	13,5	139	570	1029	54	137	614	1073	55
6 BHE 58 - 5	6"	10	7,5	644,5	G3	18,0	139	600	1245	60	137	646	1291	63
6 BHE 58 - 7	6"	15	11	830,5	G3	23,0	139	700	1531	71	137	711	1542	74
6 BHE 58 - 9	6"	20	15	1016,5	G3	27,5	139	760	1777	82	137	776	1793	84
6 BHE 58 - 10	6"	20	15	1109,5	G3	30,0	139	760	1870	84	137	776	1886	87
6 BHE 58 - 12	6"	25	18,5	1295,5	G3	34,5	139	830	2126	100	137	842	2137	98
6 BHE 58 - 14	6"	30	22	1481,5	G3	39,0	139	890	2372	109	137	907	2388	108
6 BHE 58 - 16	6"	40	30	1667,5	G3	44,0	139	1030	2698	134	137	1037	2704	128
6 BHE 58 - 18	6"	40	30	1853,5	G3	48,5	139	1030	2884	139	137	1037	2890	132
6 BHE 58 - 20	6"	50	37	2040	G3	52,0	-	-	-	-	137	1405	3445	187
6 BHE 58 - 23	6"	50	37	2318	G3	60,0	-	-	-	-	137	1405	3723	195

6BHE

6" SUBMERSED CENTRIFUGAL PUMPS

in AISI 304

SECTIONAL VIEW

6BHE 14-19-30

6BHE 44-58

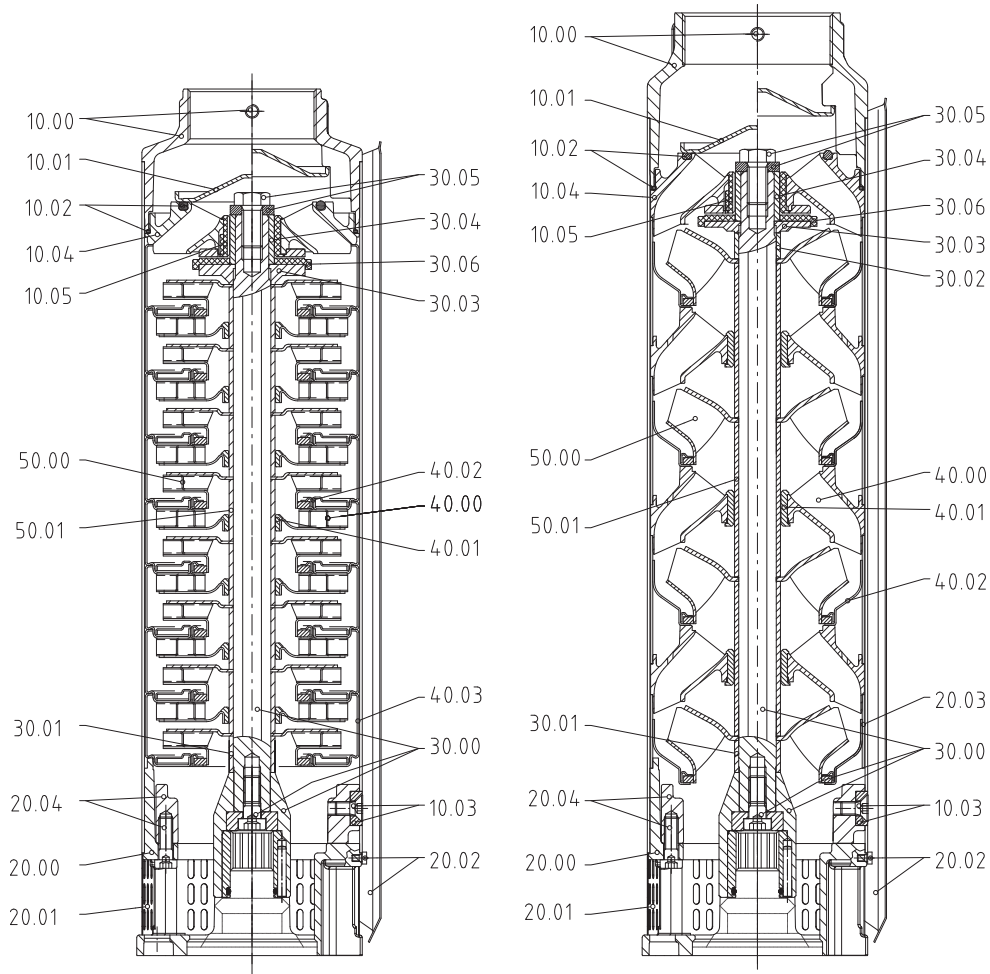

MATERIALS TABLE

Ref.	Name	Material	Ref.	Name	Material
10.00	External casing with discharge body	EN 1.4401 (AISI 316)	30.03	Thrust block washer	EN 1.4401 (AISI 316)
10.01	Valve	EN 1.4401 (AISI 316)	30.04	Upper bearing	EN 1.4460 (AISI 329) + Ceramic covering
10.02	O-Ring kit	NBR	30.05	Screw and washer	EN 1.4401 (AISI 316)
10.03	Support screw and blocking	EN 1.4401 (AISI 316)	30.06	Thrust block	PTFE
10.04	Discharge stage	EN 1.4401 (AISI 316)	40.00	Intermediate stage	EN 1.4301 (AISI 304) (standard version) EN 1.4401 (AISI 316) (L version)
10.05	Upper bush	NBR	40.01	Intermediate bush	NBR
20.00	Motor support	EN 1.4401 (AISI 316)	40.02	Intermediate stage + Wear ring	EN 1.4401 (AISI 316) / PTFE
20.01	Strainer	EN 1.4401 (AISI 316)	40.02	Wear ring	PTFE
20.02	Isolating cover	EN 1.4401 (AISI 316)	40.03	Intermediate stage (suction)	EN 1.4401 (AISI 316)
20.03	Spacer	EN 1.4401 (AISI 316)	50.00	Impeller	EN 1.4301 (AISI 304) (standard version) EN 1.4401 (AISI 316) (L version)
20.04	Flange and bolt	EN 1.4401 (AISI 316)	50.01	Intermediate bearing	EN 1.4301 (AISI 304) (standard version) EN 1.4401 (AISI 316) (L version)
30.00	Shaft with joint	EN 1.4401 (AISI 316)			
30.01	Lower spacer	EN 1.4401 (AISI 316)			
30.02	Upper spacer	EN 1.4401 (AISI 316)			

6BHE

6" SUBMERSED CENTRIFUGAL PUMPS

in AISI 304

ELECTRIC DATA TABLE 6(4)BHE WITH MOTOR IN BATH OF LIQUID REFRIGERANT

Motor	P ₂		P ₁	Voltage	IN	IA	Efficiency	Power factor
	[HP]	[kW]	[kW]					
4"	3	2,2	2,97	380/400	6,0/6,2	24	74	0,76
	4	3	4	380/400	7,9/8,0	34	75	0,78
	5,5	4	5,13	380/400	10,0/10,2	47	75	0,78
	7,5	5,5	7,24	380/400	14,0/14,4	58	76	0,79
6"	5,5	4	5,26	380/400	8,8	45	76	0,82
	7,5	5,5	7,05	380/400	12,5	64	78	0,82
	10	7,5	9,74	380/400	16,9	78	77	0,82
	12,5	9,2	11,50	380/400	21,5	95	80	0,81
	15	11	13,25	380/400	23,7	121	83	0,83
	20	15	18,29	380/400	30,4	160	82	0,85
	25	18,5	22,56	380/400	38,3	225	82	0,85
	30	22	26,51	380/400	44	250	83	0,86
	40	30	34,88	380/400	62	330	86	0,86

ELECTRIC DATA TABLE 6(4)BHE WITH MOTOR IN WATERBATH

Motor	P ₂		P ₁	Voltage	IN	IA	Efficiency	Power factor
	[HP]	[kW]	[kW]					
4"	3	2,2	2,93	400	5,9	28,9	75	0,75
	4	3	3,95	400	7,8	41,6	76	0,75
	5,5	4	5,13	400	10	58	78	0,78
	7,5	5,5	7,24	400	13,7	76	76	0,79
6"	5,5	4	5,13	400	9,3	43	78	0,82
	7,5	5,5	6,96	400	12,5	64	79	0,82
	10	7,5	9,49	400	16	83	79	0,86
	12,5	9,2	11,36	400	20,7	112	81	0,80
	15	11	13,58	400	23,3	129	81	0,85
	20	15	18,52	400	31,3	169	81	0,85
	25	18,5	22,56	400	38,5	231	82	0,85
	30	22	26,51	400	45,3	268	83	0,84
	40	30	36,14	400	63,5	393	83	0,84
	50	37	43,79	400	73	410	84,5	0,87