

## ELETTROPOMPE CENTRIFUGHE IN-LINE

in ghisa

Elettropompe centrifughe In-Line con idraulica in ghisa.

### APPLICAZIONI

- Movimentazione di liquidi in impianti di circolazione, di riscaldamento e condizionamento civili e industriali
- Movimentazione di acqua calda sanitaria e liquidi a bassa pressione in genere
- Impianti di raffreddamento e condizionamento

### PECULIARITÀ TECNICHE

- Versatili
- Silenziose

### DATI TECNICI

- Pressione massima di esercizio:
  - 6 bar per LPC 32-100 e LPC 40-100
  - 10 bar per il resto della gamma
- Temperatura massima del liquido:
  - da -10°C a +60°C per LPC 32-100
  - da -10°C a +130°C per il resto della gamma
- Temperatura massima ambiente: +40°C (oltre chiedere verifica)
- Viscosità massima del liquido convogliato: 5°E
- Motore asincrono 2 e 4 poli autoventilato
- Classe di isolamento F
- Grado di protezione IP 55
- Tensione trifase 230/400V ±10%, 50 Hz fino a 4 kW, 400/690V ±10%, 50 Hz 5,5 kW e oltre
- Protezione a cura dell'utente per la versione trifase
- Flange: PN6 per LPC 32-100 e LPC 40-100, UNI2223-29 PN16 per il resto della gamma

### MATERIALI

- Corpo pompa, disco porta tenuta, scudo, lanterna e coperchio in ghisa
- Girante in tecnopolimero per LPC 32-100, in ghisa per il resto della gamma
- Albero in AISI 420
- Tenuta meccanica in Carbone/SiC/EPDM (SiC/SiC/EPDM optional)

### ACCESSORI (su richiesta)

- Kit controflange zincate

### SIGLA IDENTIFICATIVA

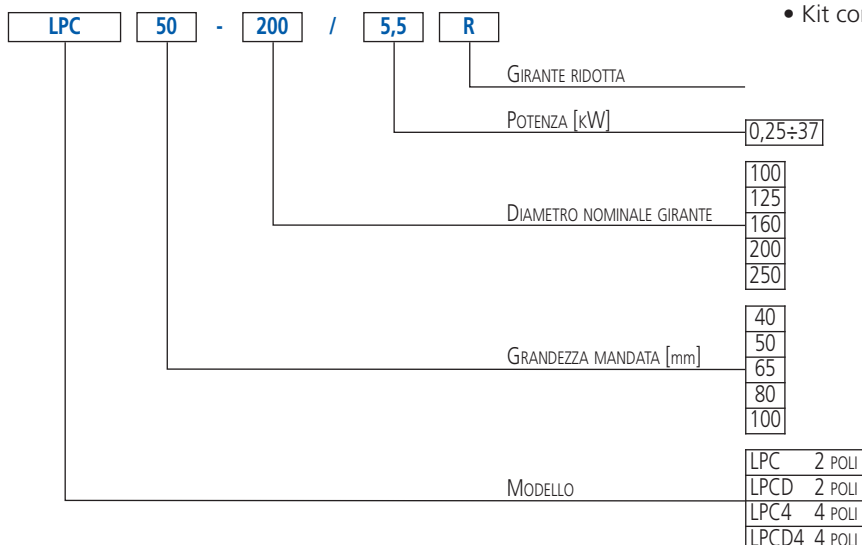

## ELETTROPOMPE CENTRIFUGHE IN-LINE

in ghisa

### GAMMA DELLE PRESTAZIONI serie LPC

(secondo ISO 9906 Allegato A)

2 Poli

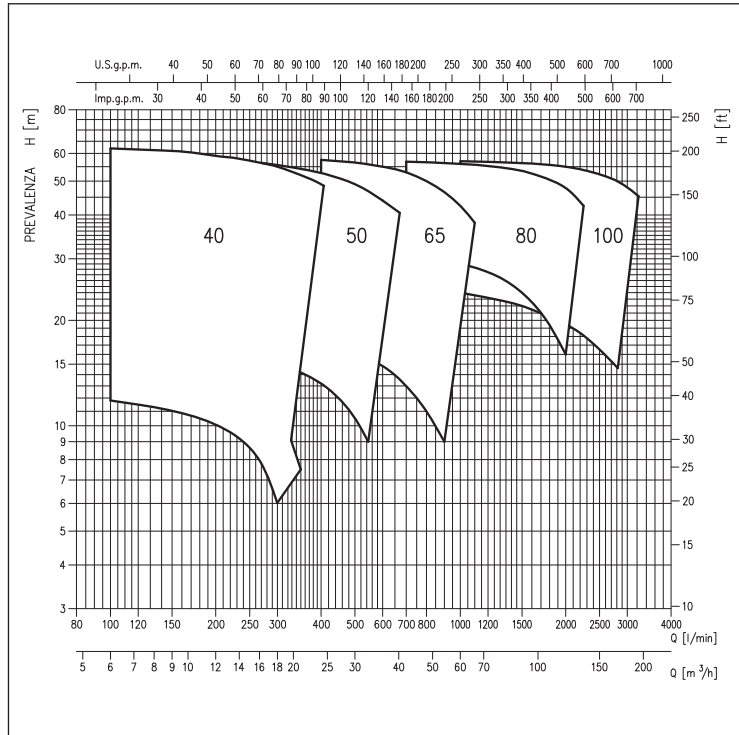

### GAMMA DELLE PRESTAZIONI serie LPCD

(secondo ISO 9906 Allegato A)

2 Poli

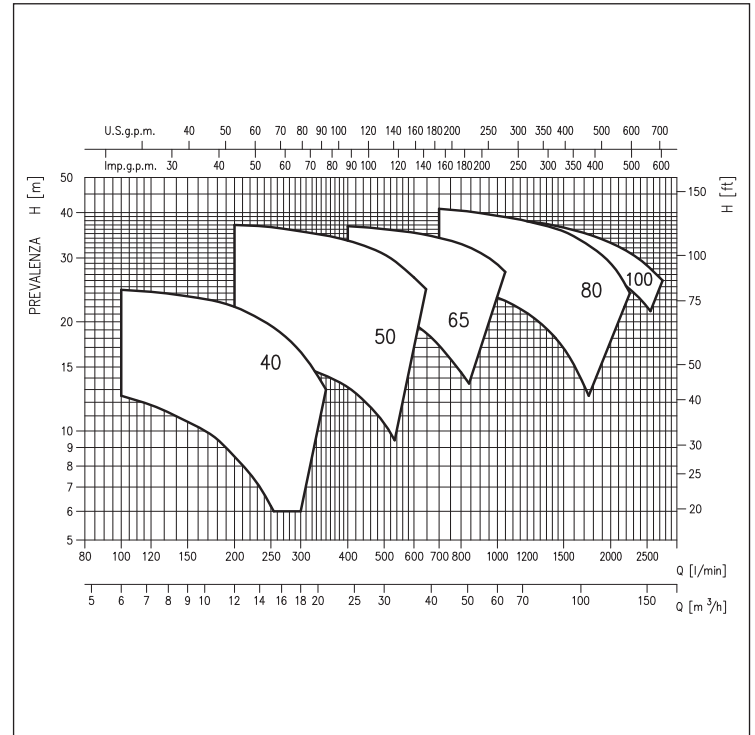

### GAMMA DELLE PRESTAZIONI serie LPC4 \*

(secondo ISO 9906 Allegato A)

4 Poli

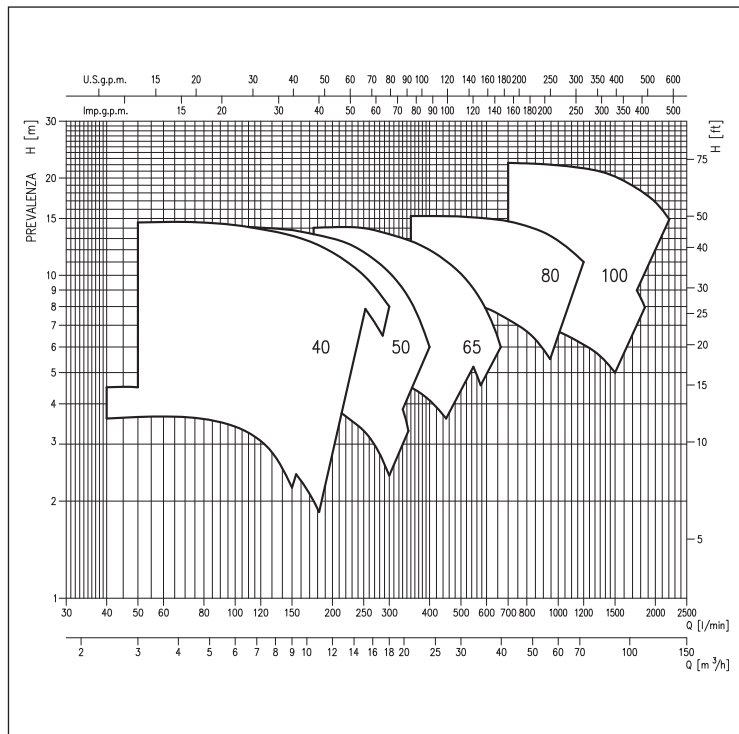

### GAMMA DELLE PRESTAZIONI serie LPCD4

(secondo ISO 9906 Allegato A)

4 Poli

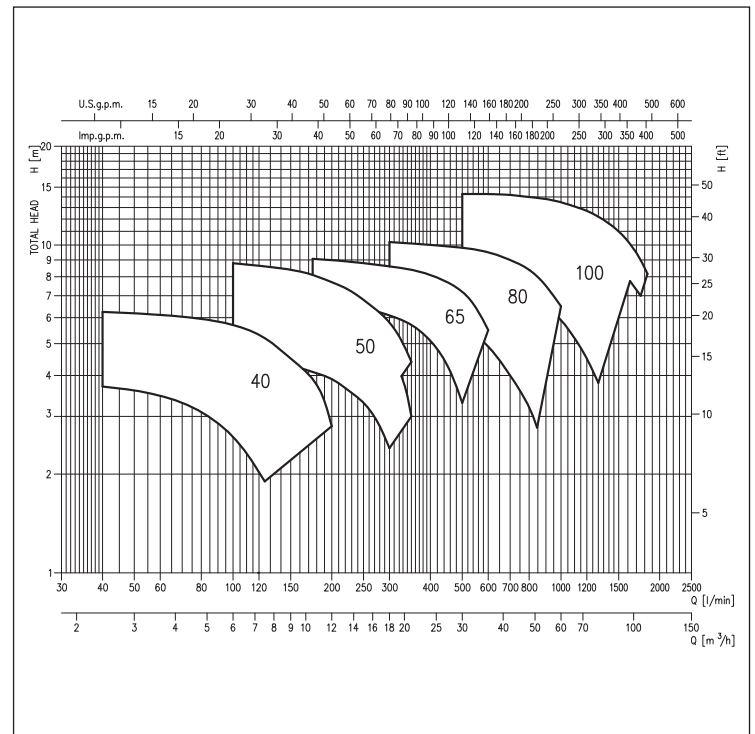

\* Disponibile ampliamento di gamma (per dati prestazionali vedi tabelle seguenti)



## ELETTROPOMPE CENTRIFUGHE IN-LINE

in ghisa

TABELLA PRESTAZIONI LPC4

4 Poli

Modello Trifase 230/400/690V	P <sub>2</sub>		Q=Portata																									
	[HP]	[kW]	H=Prevalenza [m]																									
			l/min m <sup>3</sup> /h	2,4 40	3 50	4,5 75	6 100	7,5 125	9 150	10,5 175	12 200	13,5 225	15 250	18 300	21 350	24 400	27 450	30 500	36 600	42 700	48 800	54 900	60 1000	66 1100	72 1200	78 1300		
LPC4 32-100/0,25	0,33	0,25	3,2	3,1	2,7	2,1	1,2	-	-	-	-	-	-	-	-	-	-	-	-	-	-	-	-	-	-	-	-	-
LPC4 40-100/0,25	0,33	0,25	3,6	3,55	3,5	3,3	2,9	2,5	2,0	1,5	-	-	-	-	-	-	-	-	-	-	-	-	-	-	-	-	-	-
LPC4 40-125/0,25 R	0,33	0,25	4,5	4,4	4,1	3,7	3,0	2,2	-	-	-	-	-	-	-	-	-	-	-	-	-	-	-	-	-	-	-	-
LPC4 40-125/0,25	0,33	0,25	-	6,2	6,0	5,7	5,2	4,5	3,9	2,8	-	-	-	-	-	-	-	-	-	-	-	-	-	-	-	-	-	-
LPC4 40-160/0,37	0,55	0,37	-	9,4	9,2	8,9	8,4	7,7	6,9	5,8	4,7	-	-	-	-	-	-	-	-	-	-	-	-	-	-	-	-	-
LPC4 40-200/0,75	1	0,75	-	-	12,8	12,4	11,9	11,3	10,6	9,8	9,0	8,0	6,0	-	-	-	-	-	-	-	-	-	-	-	-	-	-	-
LPC4 40-200/0,9	1,25	0,92	-	-	14,6	14,3	13,8	13,3	12,7	11,8	10,9	10,0	8,0	-	-	-	-	-	-	-	-	-	-	-	-	-	-	-
LPC4 40-250/1,1	1,5	1,1	-	-	18,7	18,0	17,5	17,0	16,0	14,5	13,0	8,5	-	-	-	-	-	-	-	-	-	-	-	-	-	-	-	-
LPC4 40-250/1,5	2	1,5	-	-	22,0	21,5	21,0	20,5	19,5	18,0	16,5	15,0	-	-	-	-	-	-	-	-	-	-	-	-	-	-	-	-
LPC4 50-125/0,25	0,33	0,25	-	-	-	4,6	4,5	4,3	4,1	3,9	3,6	3,3	2,4	-	-	-	-	-	-	-	-	-	-	-	-	-	-	-
LPC4 50-125/0,37	0,55	0,37	-	-	-	6,3	6,2	6,1	6,0	5,8	5,6	5,3	4,6	3,0	-	-	-	-	-	-	-	-	-	-	-	-	-	-
LPC4 50-160/0,5	0,75	0,55	-	-	-	8,8	8,6	8,4	8,1	7,7	7,3	6,8	5,8	4,4	-	-	-	-	-	-	-	-	-	-	-	-	-	-
LPC4 50-200/1,1 R	1,5	1,1	-	-	-	12,7	12,5	12,1	11,7	11,2	10,7	10,1	8,5	6,8	-	-	-	-	-	-	-	-	-	-	-	-	-	-
LPC4 50-200/1,1	1,5	1,1	-	-	-	14,2	14,0	13,8	13,4	13,0	12,5	11,8	10,2	8,3	6,0	-	-	-	-	-	-	-	-	-	-	-	-	-
LPC4 50-250/1,5	2	1,5	-	-	-	18,3	18,0	17,7	17,4	17,0	16,6	16,2	15,0	13,7	12,0	-	-	-	-	-	-	-	-	-	-	-	-	-
LPC4 50-250/2,2	3	2,2	-	-	-	22,5	22,3	22,0	21,7	21,4	21,0	20,5	19,5	18,5	17,0	14,0	-	-	-	-	-	-	-	-	-	-	-	-
LPC4 65-125/0,37	0,55	0,37	-	-	-	-	-	5,3	5,25	5,2	5,1	5,0	4,8	4,5	4,1	3,6	-	-	-	-	-	-	-	-	-	-	-	-
LPC4 65-125/0,5	0,75	0,55	-	-	-	-	-	6,4	6,3	6,2	6,1	6,0	5,8	5,5	5,2	4,9	4,4	-	-	-	-	-	-	-	-	-	-	-
LPC4 65-160/0,75	1	0,75	-	-	-	-	-	-	-	8,1	8,0	7,9	7,8	7,4	7,0	6,6	6,0	4,0	-	-	-	-	-	-	-	-	-	-
LPC4 65-160/0,9	1,25	0,92	-	-	-	-	-	-	-	9,0	8,9	8,8	8,7	8,4	8,1	7,7	7,2	5,5	-	-	-	-	-	-	-	-	-	-
LPC4 65-200/1,1	1,5	1,1	-	-	-	-	-	-	-	12,3	12,2	12,0	11,5	10,8	10,0	9,0	8,0	5,8	-	-	-	-	-	-	-	-	-	-
LPC4 65-200/1,5	2	1,5	-	-	-	-	-	-	-	14,1	14,1	14,0	13,6	13,0	12,1	11,2	10,1	7,8	5,0	-	-	-	-	-	-	-	-	-
LPC4 65-250/2,2	3	2,2	-	-	-	-	-	-	-	18,5	18,3	18,1	17,5	17,0	16,5	15,5	14,5	12,5	10,0	-	-	-	-	-	-	-	-	-
LPC4 65-250/3	4	3	-	-	-	-	-	-	-	22,5	22,4	22,3	22,0	21,5	20,9	20,2	19,4	17,3	15,0	-	-	-	-	-	-	-	-	-
LPC4 80-160/0,75	1	0,75	-	-	-	-	-	-	-	-	-	-	6,3	6,1	6,0	5,8	5,6	4,9	4,0	3,2	2,2	-	-	-	-	-	-	-
LPC4 80-160/0,9	1,25	0,92	-	-	-	-	-	-	-	-	-	-	7,3	7,2	7,1	7,0	6,8	6,3	5,6	4,8	3,8	-	-	-	-	-	-	-
LPC4 80-160/1,1	1,5	1,1	-	-	-	-	-	-	-	-	-	-	8,5	8,5	8,4	8,3	8,2	7,9	7,3	6,7	5,9	5,0	-	-	-	-	-	-
LPC4 80-160/1,5	2	1,5	-	-	-	-	-	-	-	-	-	-	10,2	10,1	10,0	9,9	9,8	9,5	9,0	8,4	7,5	6,5	-	-	-	-	-	-
LPC4 80-200/2,2	3	2,2	-	-	-	-	-	-	-	-	-	-	-	-	12,5	12,4	12,3	12,1	11,7	11,1	10,4	9,6	8,5	-	-	-	-	-
LPC4 80-200/3	4	3	-	-	-	-	-	-	-	-	-	-	-	-	15,3	15,3	15,2	15,0	14,6	14,2	13,6	12,8	11,9	11,0	-	-	-	-
LPC4 80-250/4	5,5	4	-	-	-	-	-	-	-	-	-	-	-	-	-	19,5	19,1	18,5	17,5	16,5	15,5	14,0	12,5	10,5	-	-	-	-
LPC4 80-250/5,5	7,5	5,5	-	-	-	-	-	-	-	-	-	-	-	-	-	-	23,0	22,6	22,2	21,4	20,6	19,7	18,7	17,5	16,0	-	-	-

Modello Trifase 230/400/690V	P <sub>2</sub>		Q=Portata																									
	[HP]	[kW]	H=Prevalenza [m]																									
			l/min m <sup>3</sup> /h	36 600	42 700	48 800	54 900	60 1000	66 1100	72 1200	78 1300	90 1500	105 1750	120 2000	135 2250	150 2500	165 2750	180 3000	210 3500	240 4000	270 4500	300 5000						
LPC4 100-160/1,5	2	1,5	7,7	7,5	7,2	7,0	6,7	6,4	6,1	5,8	5,0	-	-	-	-	-	-	-	-	-	-	-	-	-	-	-	-	-
LPC4 100-160/2,2	3	2,2	9,7	9,5	9,4	9,1	8,8	8,5	8,2	7,9	7,1	6,0	-	-	-	-	-	-	-	-	-	-	-	-	-	-	-	-
LPC4 100-200/3	4	3	12,0	11,8	11,5	11,3	10,9	10,5	10,0	9,5	8,5	7,0	-	-	-	-	-	-	-	-	-	-	-	-	-	-	-	-
LPC4 100-200/4	5,5	4	14,3	14,2	14,0	13,8	13,4	13,1	12,7	12,2	11,0	9,0	6,5	-	-	-	-	-	-	-	-	-	-	-	-	-	-	-
LPC4 100-250/5,5	7,5	5,5	-	-	19,2	18,9	18,5	18,1	17,7	17,2	16,0	14,5	12,0	-	-	-	-	-	-	-	-	-	-	-	-	-	-	-
LPC4 100-250/7,5	10	7,5	-	-	22,3	22,1	21,9	21,7	21,3	21,0	20,0	18,5	16,8	14,5	-	-	-	-	-	-	-	-	-	-	-	-	-	-
LPC4 125-250/5,5 R	7,5	5,5	-	-	-	12,2	11,9	11,8	11,0	10,6	9,6	8,0	6,0	3,5	-	-	-	-	-	-	-	-	-	-	-	-	-	-
LPC4 125-250/5,5	7,5	5,5	-	-	-	15,5	15,2	15,0	14,6	14,1	12,4	12,0	10,0	8,0	6,0	-	-	-	-	-	-	-	-	-	-	-	-	-
LPC4 125-250/7,5	10	7,5	-	-	-	-	19,5	19,0	18,8	18,3	18,0	17,0	15,7	14,0	12,5	10,5	-	-	-	-	-	-	-	-	-	-	-	-
LPC4 125-250/9,2	12,5	9,2	-	-	-	-	21,6	21,4	21,3	21,2	20,8	20,0	19,0	17,8	16,2	14,2	12,0	-	-	-	-	-	-	-	-	-	-	-
LPC4 150-250/7,5	10	7,5	-	-	-	-	-	-	-	15,0	14,7	14,3	13,8	13,3	12,6	11,8	11,0	9,0	6,5	-	-	-	-	-	-	-	-	-
LPC4 150-250/9,2	12,5	9,2	-	-	-	-	-	-	-	-	16,7	16,5	16,0	15,5	15,0	14,2	13,5	11,8	9,5	7,4	-	-	-	-	-	-	-	-
LPC4 150-250/11	15	11	-	-	-	-	-	-	-	-	-	18,5	18,0	17,7	17,2	16,7	16,2	15,3	13,6	11,5	9,4	-	-	-	-	-	-	-
LPC4 150-250/15 R	20	15	-	-	-	-	-	-	-	-	-	-	-	19,8	19,5	19,0	18,6	18,0	17,4	15,7	13,9	11,9	9,6	-	-	-	-	-
LPC4 150-250/15	20	15	-	-	-	-	-	-	-	-	-	-	-	20,8	20,5	19,8	19,5	19,0	18,5	17,0	15,0	13,0	11,0	-	-	-	-	-

## ELETTROPOMPE CENTRIFUGHE IN-LINE

in ghisa

2 Poli

TABELLA PRESTAZIONI LPCD

Modello Trifase 230/400/690V	P <sub>2</sub>		Q=Portata																											
	[HP]	[kW]	H=Prevalenza [m]																											
			l/min	6	7,5	9	10,5	12	13,5	15	18	21	24	27	30	36	42	48	54	60	75	90	105	120	135	165	180	195	210	225
LPCD 40-125/0,55	0,75	0,55	12,5	11,6	10,6	9,7	8,5	7,4	6,2	-	-	-	-	-	-	-	-	-	-	-	-	-	-	-	-	-	-	-	-	-
LPCD 40-125/0,75	1	0,75	15,3	14,5	13,7	12,8	11,5	10,4	9,0	6,0	-	-	-	-	-	-	-	-	-	-	-	-	-	-	-	-	-	-	-	-
LPCD 40-125/1	1,5	1,1	20,5	19,7	19,0	18,1	17,1	15,9	14,5	11,2	7,5	-	-	-	-	-	-	-	-	-	-	-	-	-	-	-	-	-	-	-
LPCD 40-125/1,5	2	1,5	24,5	24,1	23,5	22,9	22,0	20,8	19,5	16,5	13,0	-	-	-	-	-	-	-	-	-	-	-	-	-	-	-	-	-	-	-
LPCD 50-125/1,5	2	1,5	-	-	-	-	16,0	15,7	15,5	15,0	14,2	13,2	11,9	10,5	7,0	-	-	-	-	-	-	-	-	-	-	-	-	-	-	-
LPCD 50-125/2	3	2,2	-	-	-	-	19,5	19,3	19,1	18,5	17,5	16,6	15,5	14,1	10,5	-	-	-	-	-	-	-	-	-	-	-	-	-	-	-
LPCD 50-125/3	4	3	-	-	-	-	24,7	24,6	24,5	24,2	23,7	23,0	21,8	20,5	17,0	-	-	-	-	-	-	-	-	-	-	-	-	-	-	-
LPCD 50-160/3	4	3	-	-	-	-	30,5	30,2	29,9	29,0	27,8	26,5	24,9	23,0	18,0	-	-	-	-	-	-	-	-	-	-	-	-	-	-	-
LPCD 50-160/4	5,5	4	-	-	-	-	37,0	36,8	36,5	35,5	34,6	33,5	32,2	30,7	26,5	-	-	-	-	-	-	-	-	-	-	-	-	-	-	-
LPCD 65-160/3	4	3	-	-	-	-	-	-	-	-	23,0	22,5	22,0	21,3	19,7	17,2	14,5	-	-	-	-	-	-	-	-	-	-	-	-	-
LPCD 65-160/4	5,5	4	-	-	-	-	-	-	-	-	27,0	26,6	26,0	25,5	24,2	22,5	20,2	16,8	-	-	-	-	-	-	-	-	-	-	-	-
LPCD 65-160/5,5	7,5	5,5	-	-	-	-	-	-	-	-	32,3	32,0	31,5	30,8	29,5	28,0	25,8	23,5	-	-	-	-	-	-	-	-	-	-	-	-
LPCD 65-160/7,5	10	7,5	-	-	-	-	-	-	-	-	36,7	36,4	36,0	35,2	34,1	32,8	31,0	28,8	-	-	-	-	-	-	-	-	-	-	-	-
LPCD 80-160/7,5	10	7,5	-	-	-	-	-	-	-	-	-	-	-	-	25,5	25,2	24,7	24,0	23,3	20,5	16,9	12,5	-	-	-	-	-	-	-	-
LPCD 80-160/10	13,6	10	-	-	-	-	-	-	-	-	-	-	-	-	-	30,5	30,0	29,5	29,0	27,0	24,0	20,2	16,0	-	-	-	-	-	-	-
LPCD 80-160/12,5	17	12,5	-	-	-	-	-	-	-	-	-	-	-	-	-	36,0	35,5	35,0	34,5	32,8	30,0	27,0	23,0	19,0	-	-	-	-	-	-
LPCD 80-160/15	20	15	-	-	-	-	-	-	-	-	-	-	-	-	-	41,0	40,5	39,9	39,2	37,5	35,5	32,5	29,0	24,0	-	-	-	-	-	-
LPCD 100-200/10	13,5	10	-	-	-	-	-	-	-	-	-	-	-	-	-	-	-	-	24,5	23,5	22,0	20,5	18,5	16,0	10,5	7,0	3,0	-	-	-
LPCD 100-200/12,5 R	17	12,5	-	-	-	-	-	-	-	-	-	-	-	-	-	-	-	-	33,0	32,5	31,0	29,0	27,0	24,5	19,0	-	-	-	-	-
LPCD 100-200/12,5	17	12,5	-	-	-	-	-	-	-	-	-	-	-	-	-	-	-	-	27,5	26,5	25,5	24,0	22,0	20,0	15,0	12,0	8,6	5,0	-	-
LPCD 100-200/15 R	20	15	-	-	-	-	-	-	-	-	-	-	-	-	-	-	-	-	-	37,5	36,5	35,0	33,0	31,0	26,0	-	-	-	-	-
LPCD 100-200/15	20	15	-	-	-	-	-	-	-	-	-	-	-	-	-	-	-	-	-	28,0	27,0	25,5	23,5	21,5	16,5	13,8	10,8	7,5	3,0	-

TABELLA PRESTAZIONI LPCD4

4 Poli

Modello Trifase 230/400/690V	P <sub>2</sub>		Q=Portata																											
	[HP]	[kW]	H=Prevalenza [m]																											
			l/min	0	2,4	3	4,5	6	7,5	9	10,5	12	13,5	15	18	21	24	27	30	36	42	48	54	60	66	72	78	90	105	120
LPCD4 40-100/0,25	0,33	0,25	4,0	3,7	3,6	3,1	2,6	1,9	-	-	-	-	-	-	-	-	-	-	-	-	-	-	-	-	-	-	-	-	-	-
LPCD4 40-125/0,25 R	0,33	0,25	4,8	4,5	4,4	4,1	3,7	3,0	2,2	-	-	-	-	-	-	-	-	-	-	-	-	-	-	-	-	-	-	-	-	-
LPCD4 40-125/0,25	0,33	0,25	6,3	-	6,2	6,0	5,7	5,2	4,5	3,9	2,8	-	-	-	-	-	-	-	-	-	-	-	-	-	-	-	-	-	-	-
LPCD4 50-125/0,25	0,33	0,25	4,8	-	-	-	4,6	4,5	4,3	4,1	3,9	3,6	3,3	2,4	-	-	-	-	-	-	-	-	-	-	-	-	-	-	-	-
LPCD4 50-125/0,37	0,5	0,37	6,4	-	-	-	6,3	6,2	6,1	6,0	5,8	5,6	5,3	4,6	3,0	-	-	-	-	-	-	-	-	-	-	-	-	-	-	-
LPCD4 50-160/0,5	0,7	0,5	9,2	-	-	-	8,8	8,6	8,4	8,1	7,7	7,3	6,8	5,8	4,4	-	-	-	-	-	-	-	-	-	-	-	-	-	-	-
LPCD4 65-160/0,55	0,75	0,55	6,9	-	-	-	-	6,8	6,7	6,6	6,5	6,4	6,1	5,7	5,1	4,3	3,3	-	-	-	-	-	-	-	-	-	-	-	-	-
LPCD4 65-160/0,75	1	0,75	8,3	-	-	-	-	-	-	8,1	8,0	7,9	7,8	7,4	7,0	6,6	6,0	4,0	-	-	-	-	-	-	-	-	-	-	-	-
LPCD4 65-160/0,9	1,25	0,9	9,1	-	-	-	-	-	-	9,0	8,9	8,8	8,7	8,4	8,1	7,7	7,2	5,5	-	-	-	-	-	-	-	-	-	-	-	-
LPCD4 80-160/0,75	1	0,75	6,4	-	-	-	-	-	-	-	-	-	6,3	6,1	6,0	5,8	5,6	4,9	4,0	3,2	2,2	-	-	-	-	-	-	-	-	-
LPCD4 80-160/0,9	1,25	0,9	7,4	-	-	-	-	-	-	-	-	-	7,3	7,2	7,1	7,0	6,8	6,3	5,6	4,8	3,8	-	-	-	-	-	-	-	-	-
LPCD4 80-160/1,1	1,5	1,1	8,6	-	-	-	-	-	-	-	-	-	8,5	8,5	8,4	8,3	8,2	7,9	7,3	6,7	5,9	5,0	-	-	-	-	-	-	-	-
LPCD4 80-160/1,5	2	1,5	10,3	-	-	-	-	-	-	-	-	-	10,2	10,1	10,0	9,9	9,8	9,5	9,0	8,4	7,5	6,5	-	-	-	-	-	-	-	-
LPCD4 100-200/1,5	2	1,5	8,6	-	-	-	-	-	-	-	-	-	-	-	-	-	8,1	7,8	7,4	7,0	6,5	5,9	5,2	4,5	3,8	-	-	-	-	-
LPCD4 100-200/2,2	3	2,2	10,6	-	-	-	-	-	-	-	-	-	-	-	-	-	10,2	10,0	9,7	9,3	9,0	8,6	8,2	7,7	7,2	6,0	-	-	-	-
LPCD4 100-200/3	4	3	12,7	-	-	-	-	-	-	-	-	-	-	-	-	-	-	12,0	11,8	11,5	11,3	10,9	10,5	10,0	9,5	8,5	7,0	-	-	-
LPCD4 100-200/4	5,5	4	14,9	-	-	-	-	-	-	-	-	-	-	-	-	-	-	14,3	14,2	14,0	13,8	13,4	13,1	12,7	12,2	11,0	9,0	6,5	-	-

FUNZIONAMENTO AUTOMATICO DELLA VALVOLA DI NON-RITORNO

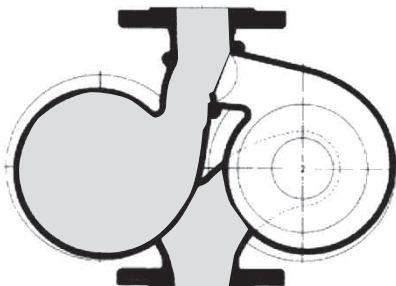

POMPA SINISTRA IN FUNZIONE

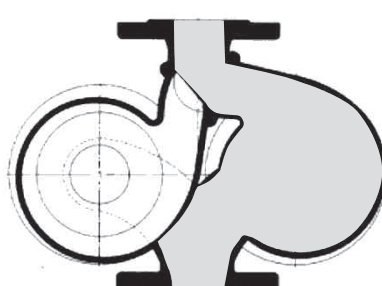

POMPA DESTRA IN FUNZIONE

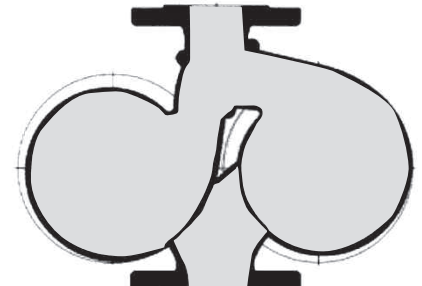

FUNZIONAMENTO IN PARALLELO

## ELETTROPOMPE CENTRIFUGHE IN-LINE

in ghisa

### CURVE DI PRESTAZIONE serie LPC 40-100

(secondo ISO 9906 Allegato A)

2 Poli

### CURVE DI PRESTAZIONE serie LPC 40-125

(secondo ISO 9906 Allegato A)

2 Poli

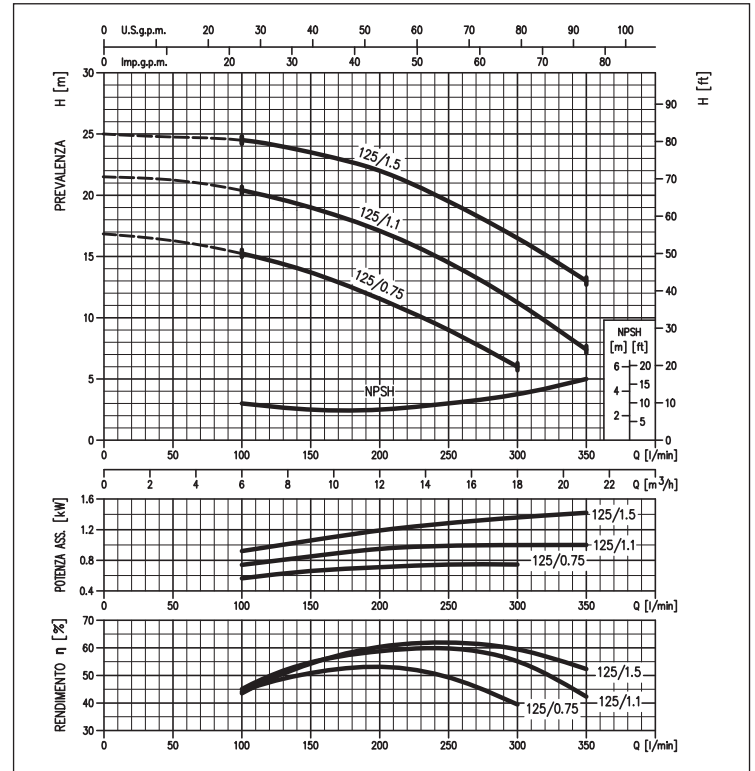
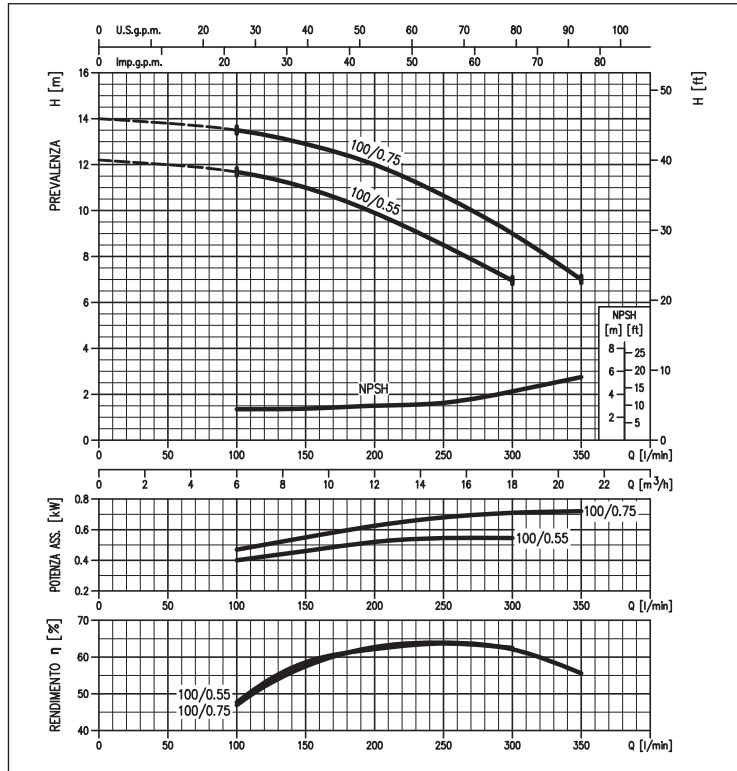

### CURVE DI PRESTAZIONE serie LPC 40-160

(secondo ISO 9906 Allegato A)

2 Poli

### CURVE DI PRESTAZIONE serie LPC 40-200

(secondo ISO 9906 Allegato A)

2 Poli

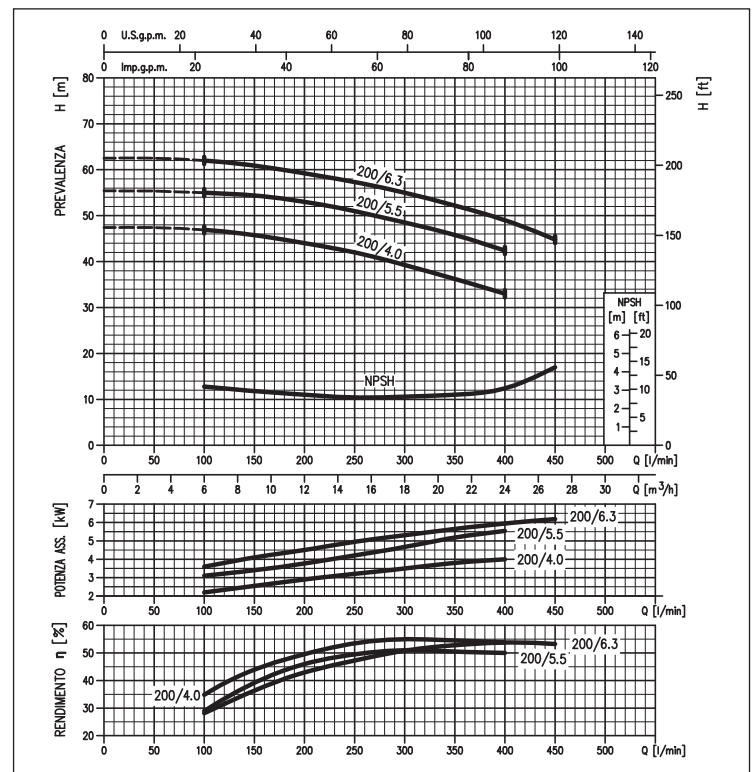
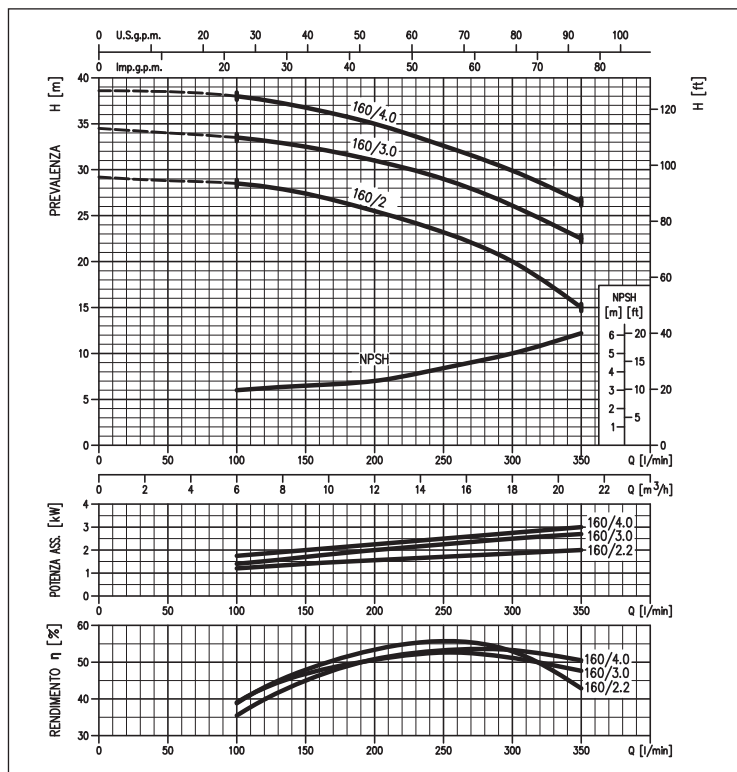

## ELETTROPOMPE CENTRIFUGHE IN-LINE

in ghisa

### CURVE DI PRESTAZIONE serie LPC 50-125

(secondo ISO 9906 Allegato A)

2 Poli

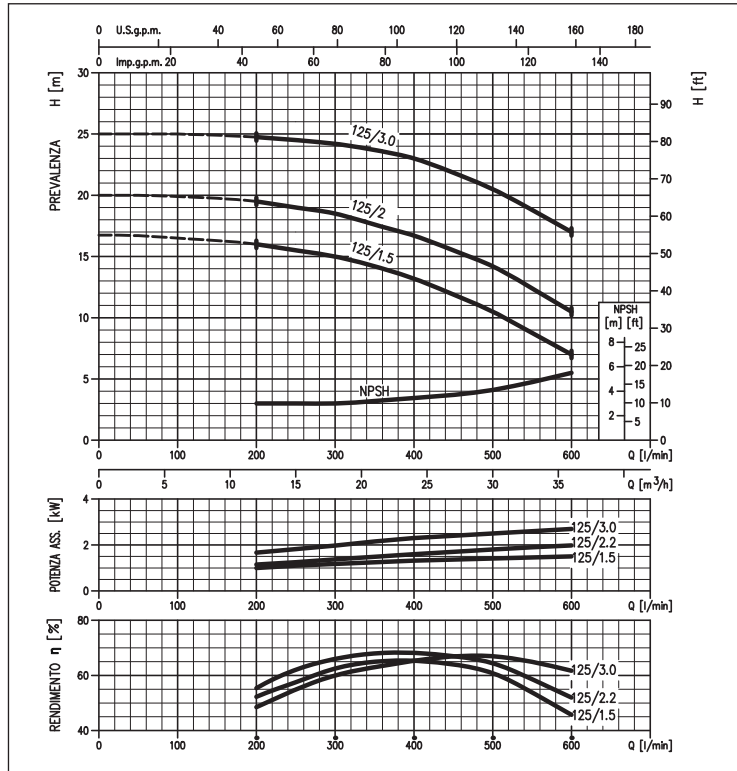

### CURVE DI PRESTAZIONE serie LPC 50-160

(secondo ISO 9906 Allegato A)

2 Poli

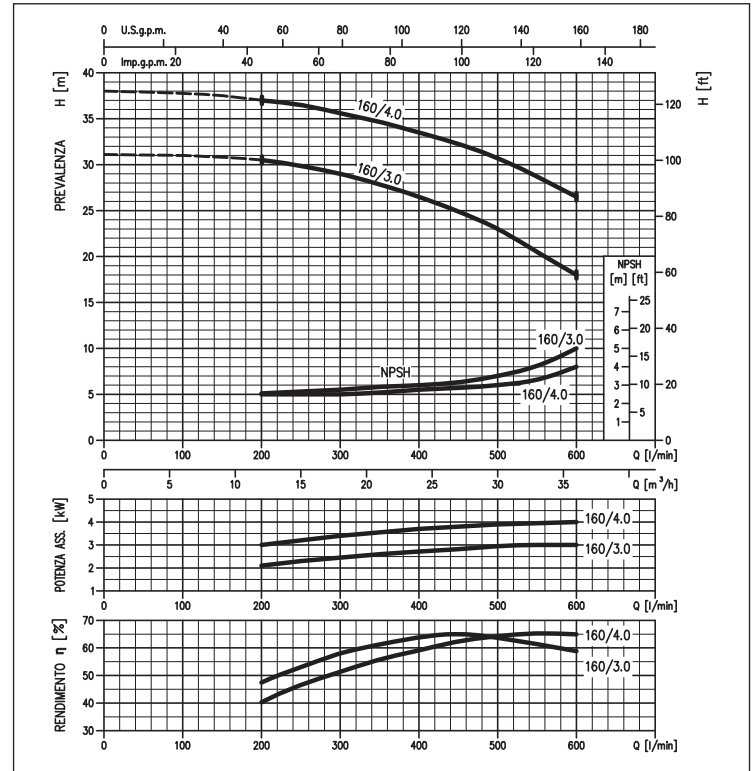

### CURVE DI PRESTAZIONE serie LPC 50-200

(secondo ISO 9906 Allegato A)

2 Poli

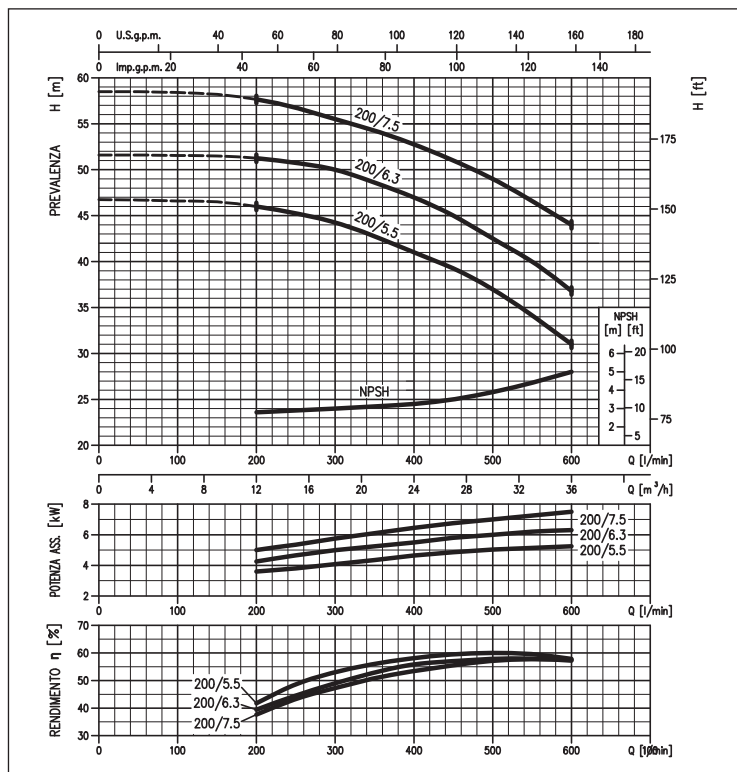

### CURVE DI PRESTAZIONE serie LPC 65-125

(secondo ISO 9906 Allegato A)

2 Poli

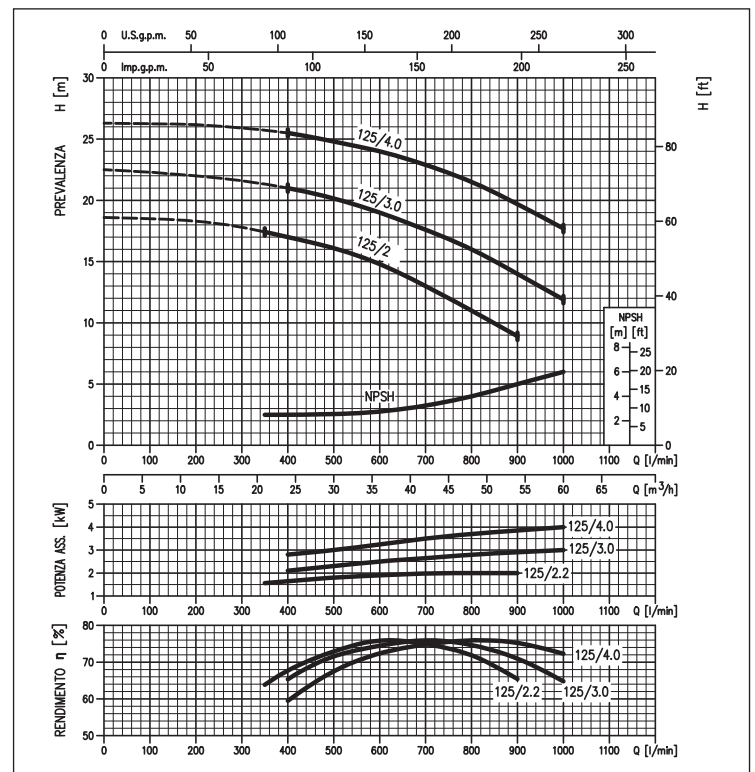

## ELETTROPOMPE CENTRIFUGHE IN-LINE

in ghisa

### CURVE DI PRESTAZIONE serie LPC 65-160

(secondo ISO 9906 Allegato A)

2 Poli

### CURVE DI PRESTAZIONE serie LPC 65-200

(secondo ISO 9906 Allegato A)

2 Poli

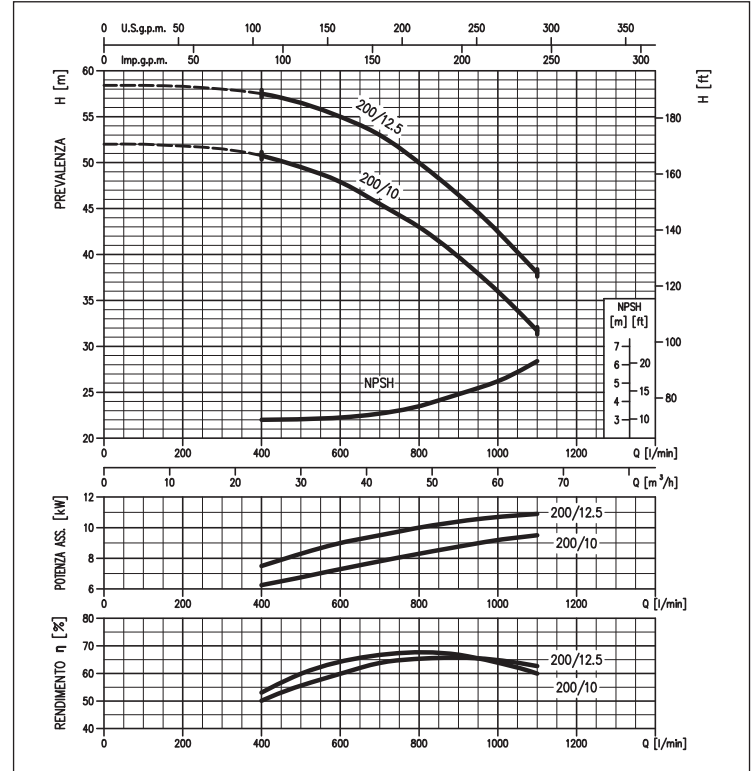
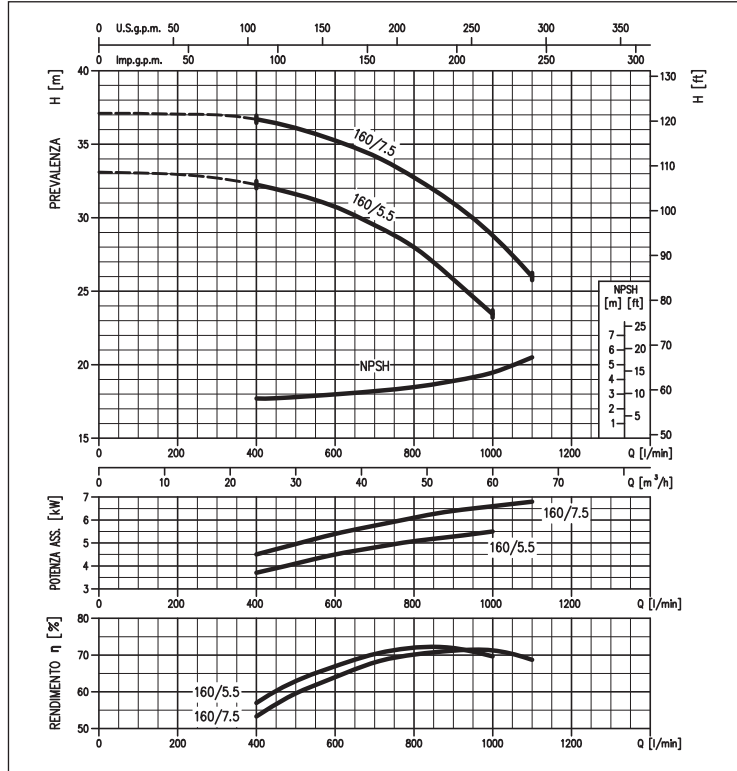

### CURVE DI PRESTAZIONE serie LPC 80-160

(secondo ISO 9906 Allegato A)

2 Poli

### CURVE DI PRESTAZIONE serie LPC 80-200

(secondo ISO 9906 Allegato A)

2 Poli

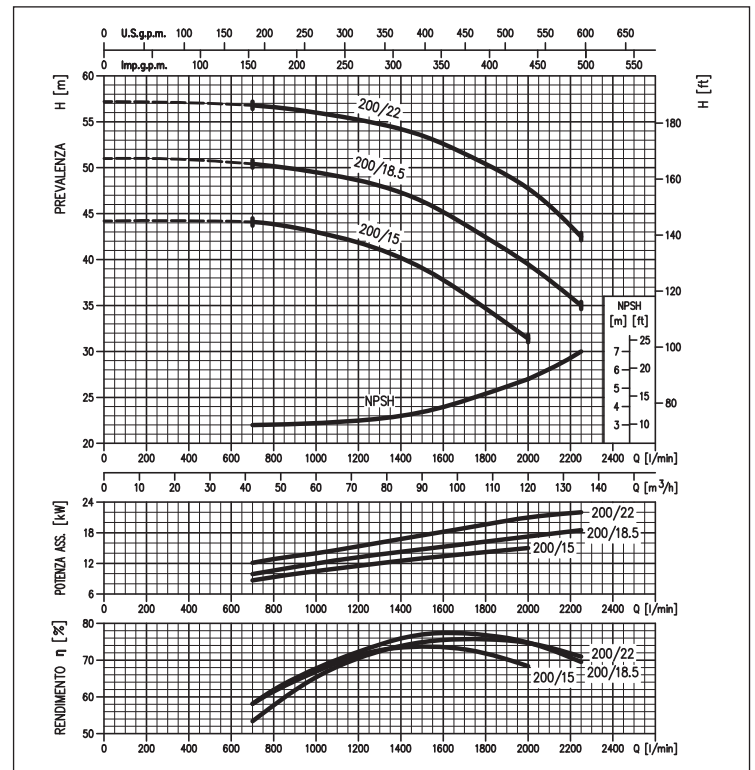
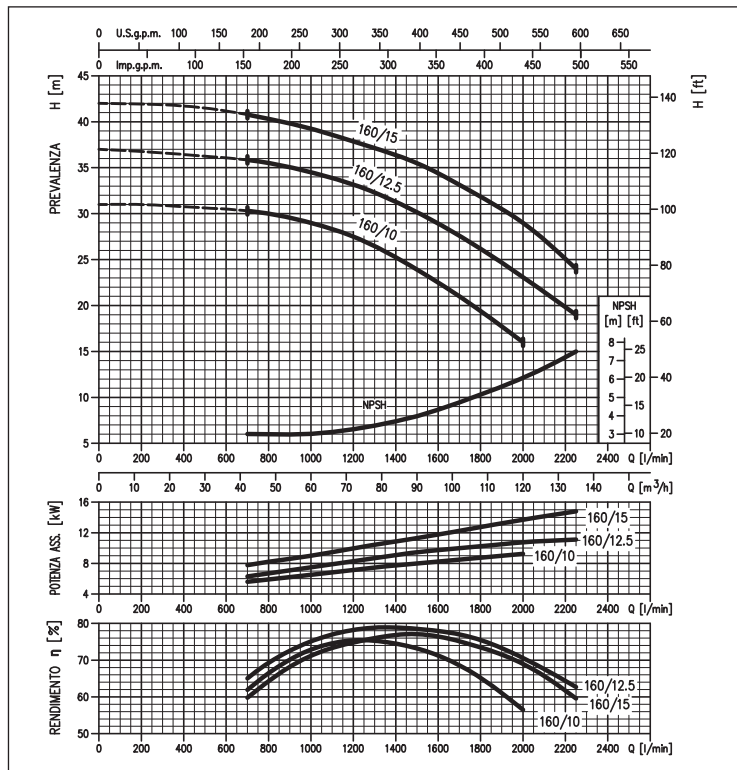

## ELETTROPOMPE CENTRIFUGHE IN-LINE

in ghisa

### CURVE DI PRESTAZIONE serie LPC 100-160

(secondo ISO 9906 Allegato A)

2 Poli

### CURVE DI PRESTAZIONE serie LPC 100-200

(secondo ISO 9906 Allegato A)

2 Poli

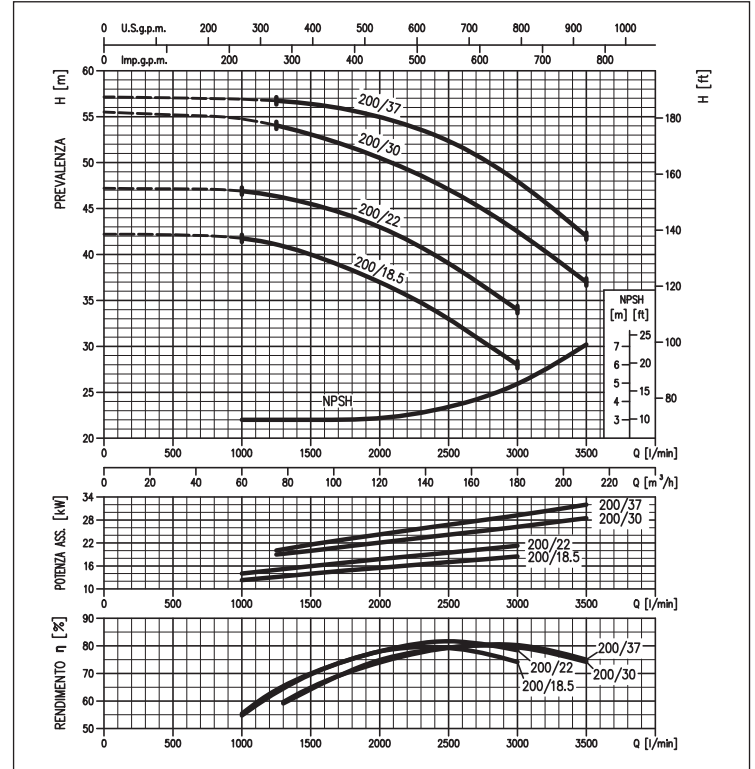
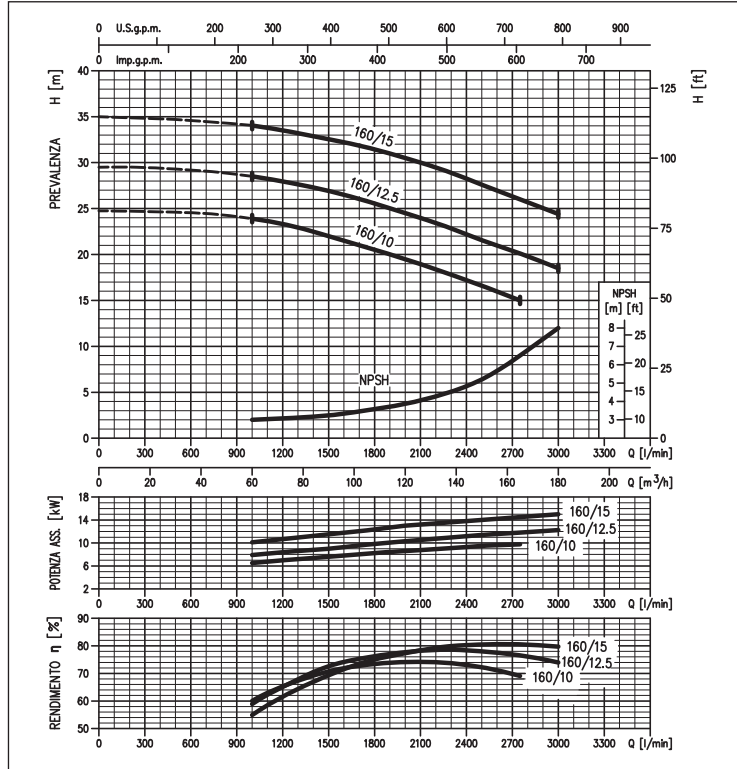

### CURVE DI PRESTAZIONE serie LPC 100-250

(secondo ISO 9906 Allegato A)

2 Poli

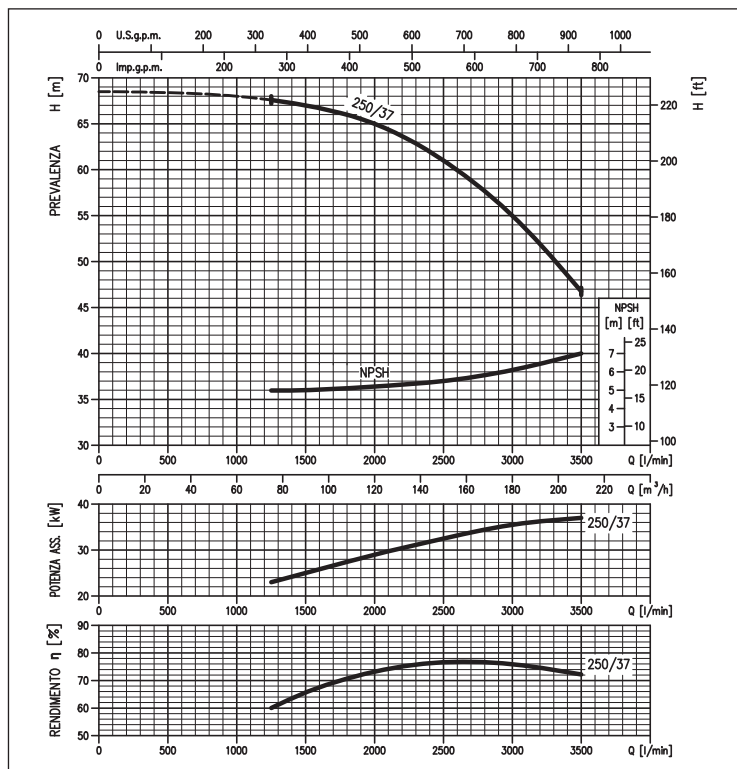

## ELETTROPOMPE CENTRIFUGHE IN-LINE

in ghisa

### CURVE DI PRESTAZIONE serie LPCD 40-125

(secondo ISO 9906 Allegato A)

2 Poli

### CURVE DI PRESTAZIONE serie LPCD 50-125

(secondo ISO 9906 Allegato A)

2 Poli

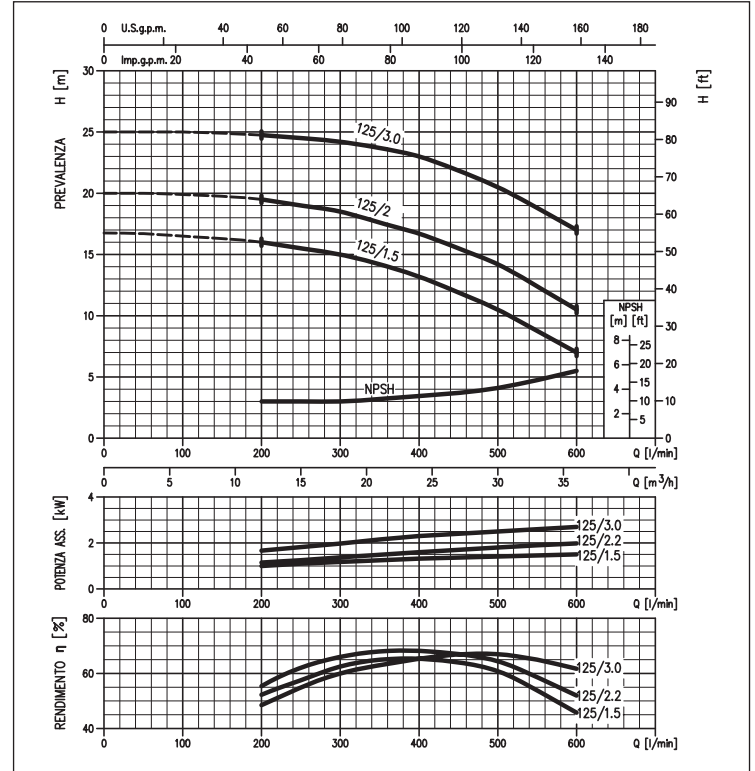
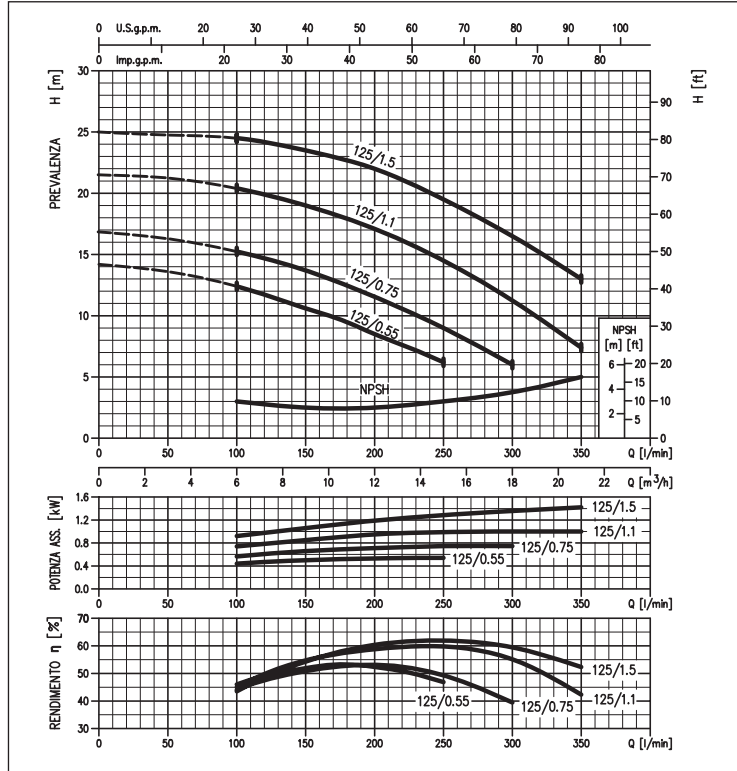

### CURVE DI PRESTAZIONE serie LPCD 50-160

(secondo ISO 9906 Allegato A)

2 Poli

### CURVE DI PRESTAZIONE serie LPCD 65-160

(secondo ISO 9906 Allegato A)

2 Poli

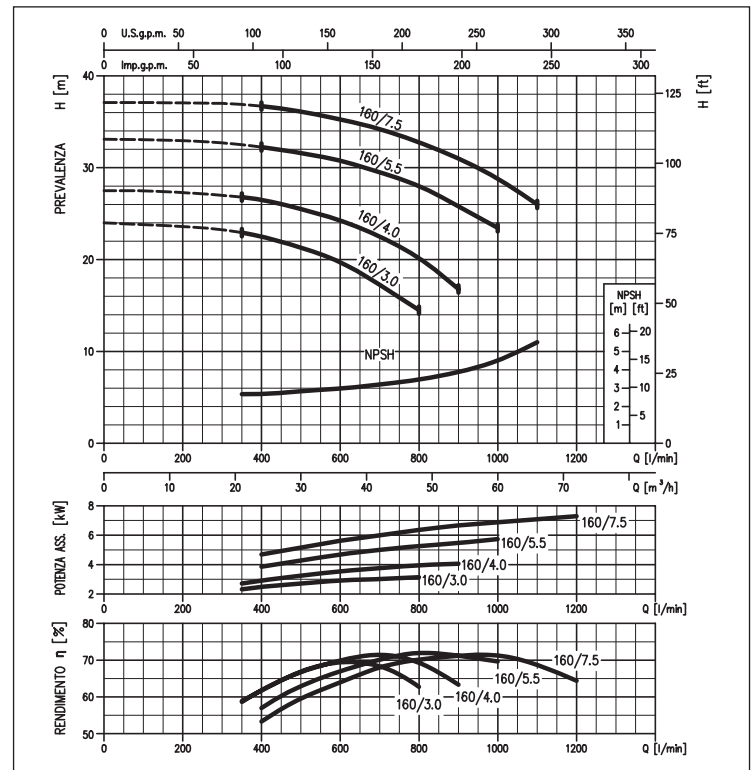
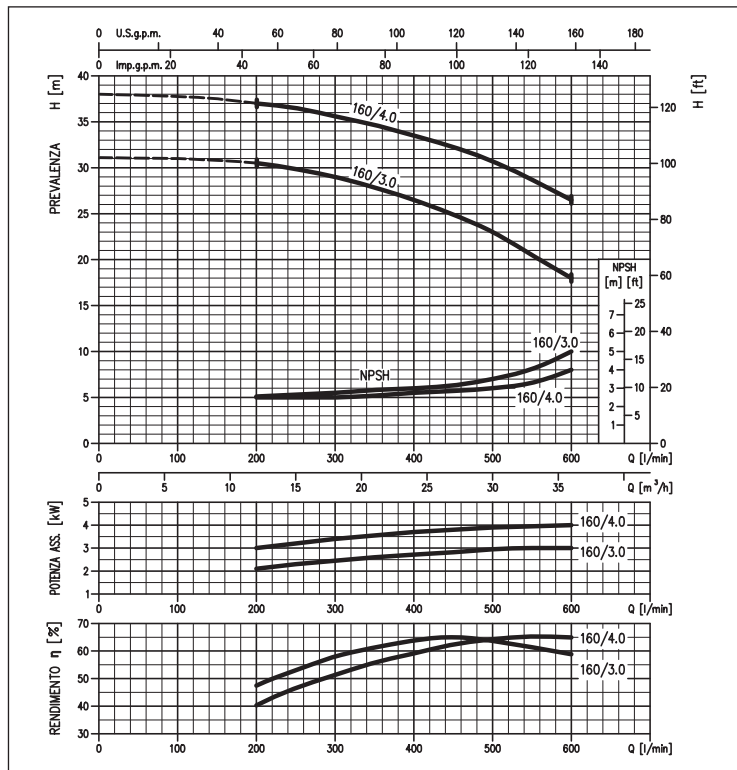

## ELETTROPOMPE CENTRIFUGHE IN-LINE

in ghisa

### CURVE DI PRESTAZIONE serie LPCD 80-160

(secondo ISO 9906 Allegato A)

2 Poli

### CURVE DI PRESTAZIONE serie LPCD 100-200

(secondo ISO 9906 Allegato A)

2 Poli

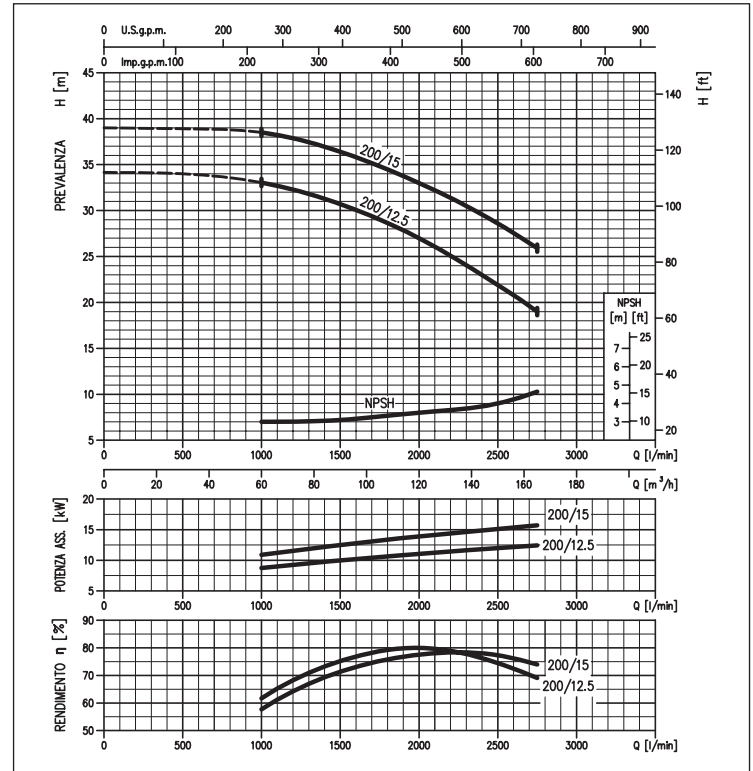
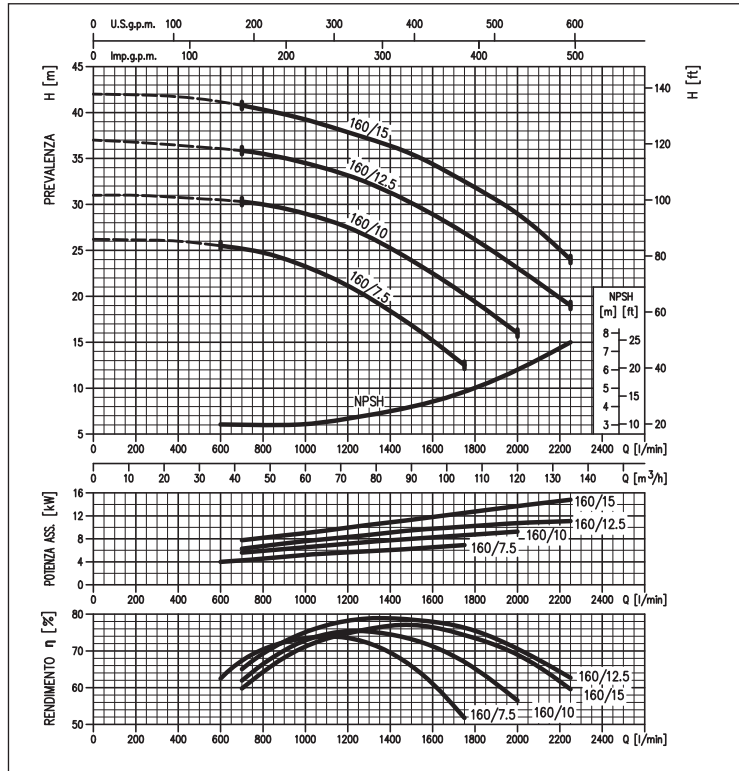

## ELETTROPOMPE CENTRIFUGHE IN-LINE

in ghisa

### CURVE DI PRESTAZIONE serie LPC4 40-100

(secondo ISO 9906 Allegato A)

4 Poli

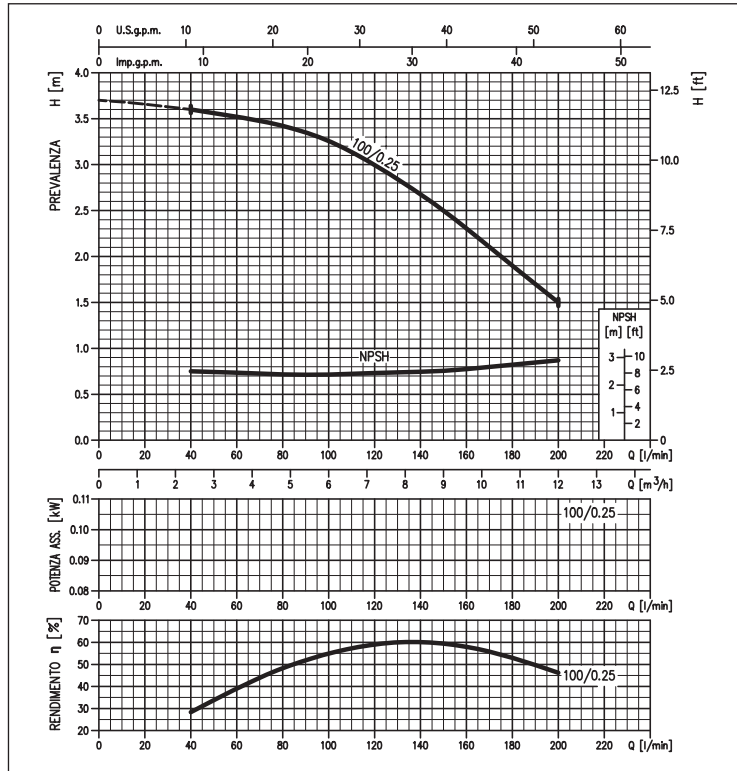

### CURVE DI PRESTAZIONE serie LPC4 40-125

(secondo ISO 9906 Allegato A)

4 Poli

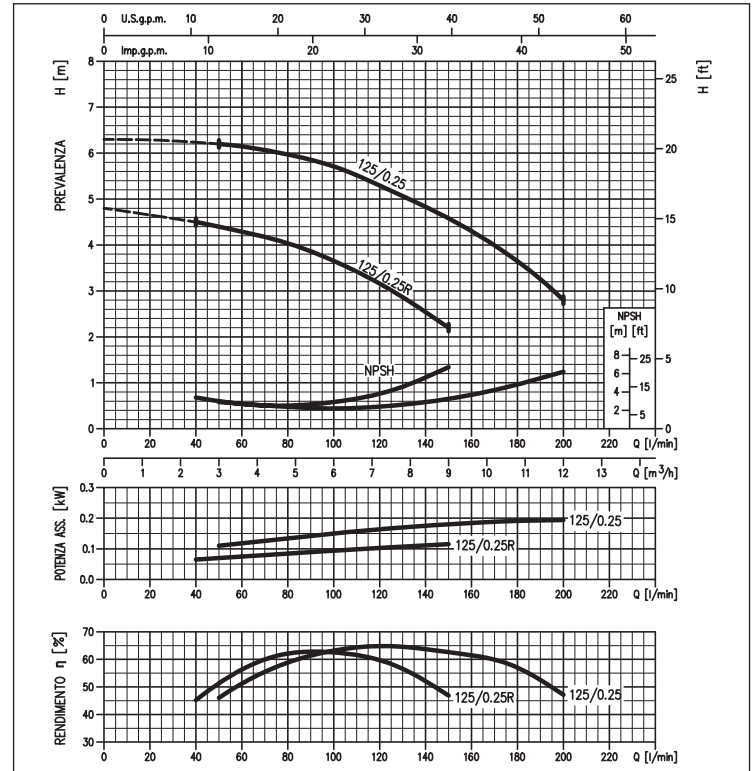

### CURVE DI PRESTAZIONE serie LPC4 40-160

(secondo ISO 9906 Allegato A)

4 Poli

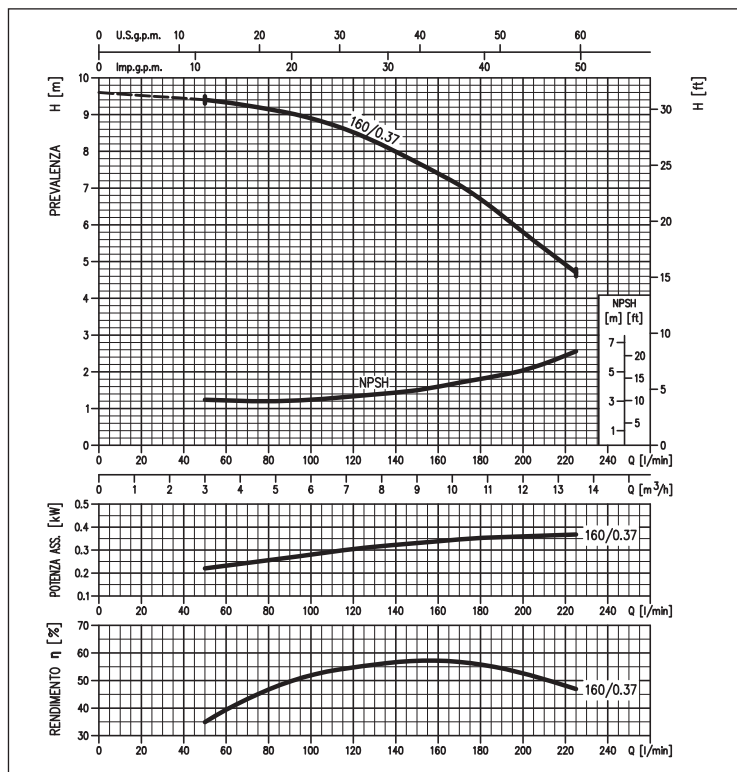

### CURVE DI PRESTAZIONE serie LPC4 40-200

(secondo ISO 9906 Allegato A)

4 Poli

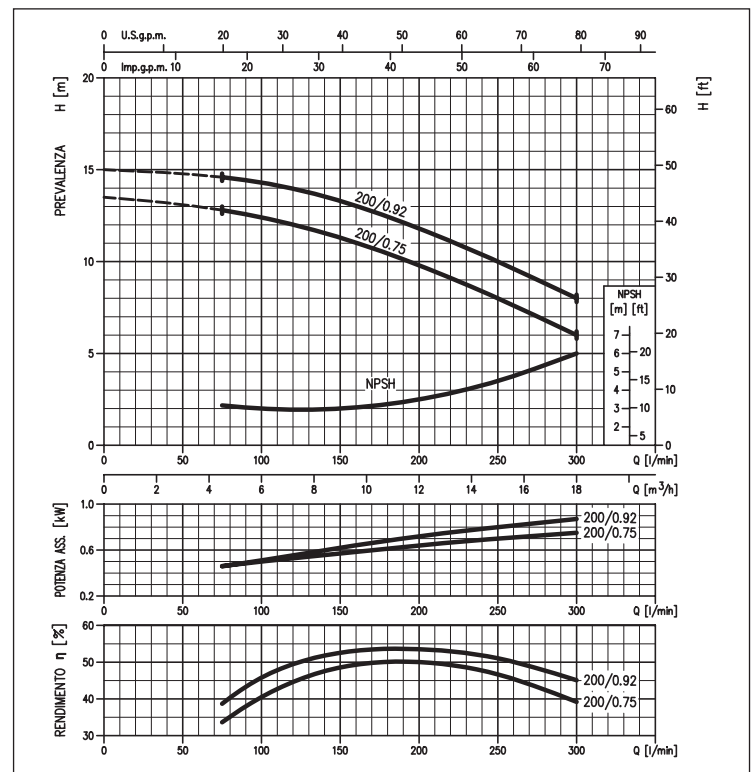

## ELETTROPOMPE CENTRIFUGHE IN-LINE

in ghisa

### CURVE DI PRESTAZIONE serie LPC4 50-125

(secondo ISO 9906 Allegato A)

4 Poli

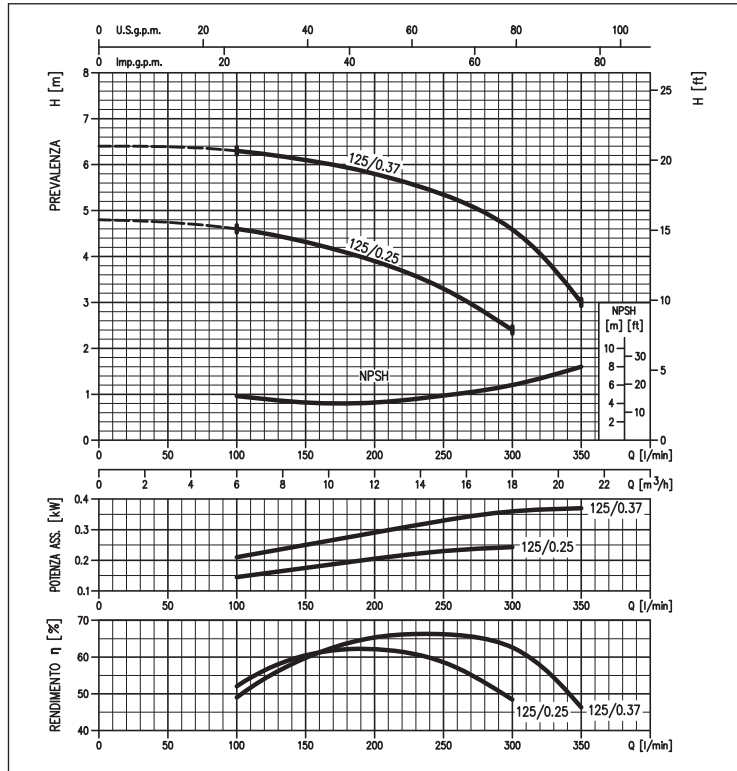

### CURVE DI PRESTAZIONE serie LPC4 50-160

(secondo ISO 9906 Allegato A)

4 Poli

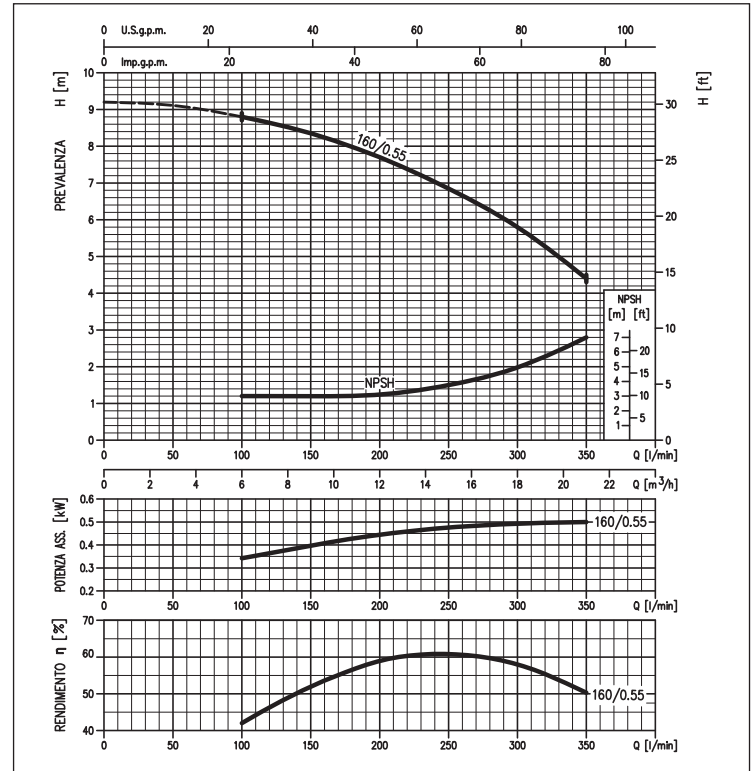

### CURVE DI PRESTAZIONE serie LPC4 50-200

(secondo ISO 9906 Allegato A)

4 Poli

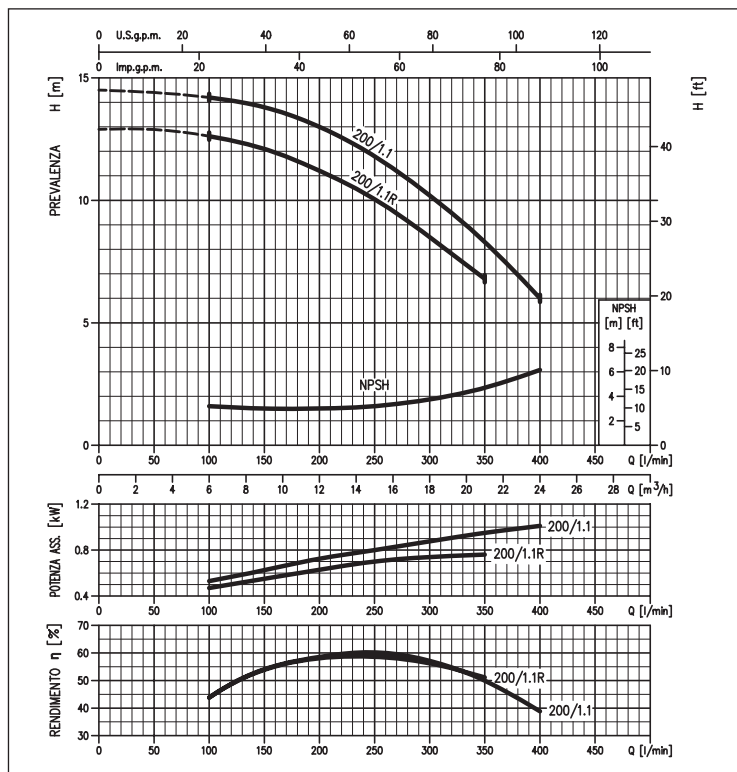

### CURVE DI PRESTAZIONE serie LPC4 65-125

(secondo ISO 9906 Allegato A)

4 Poli

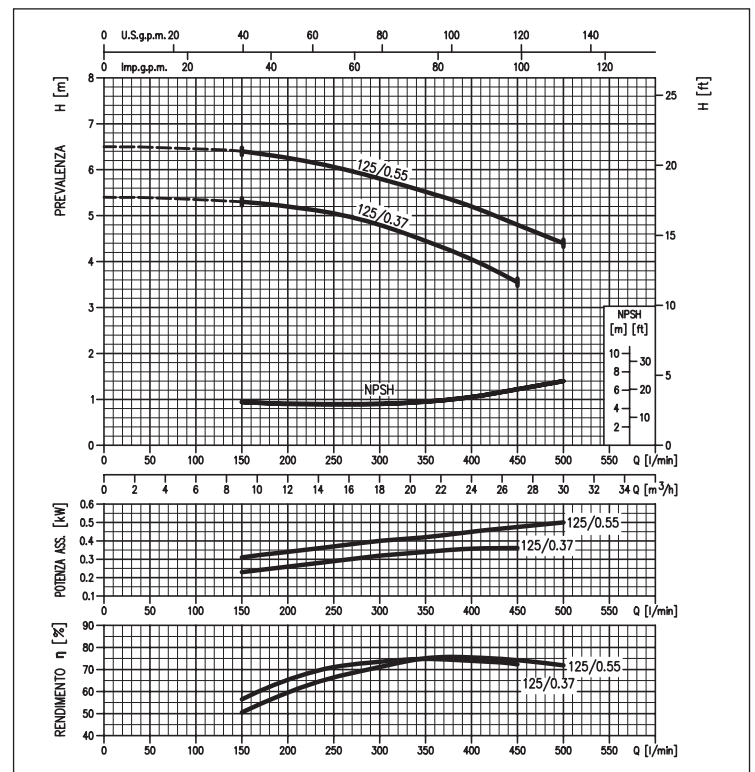

## ELETTROPOMPE CENTRIFUGHE IN-LINE

in ghisa

### CURVE DI PRESTAZIONE serie LPC 65-160

(secondo ISO 9906 Allegato A)

4 Poli

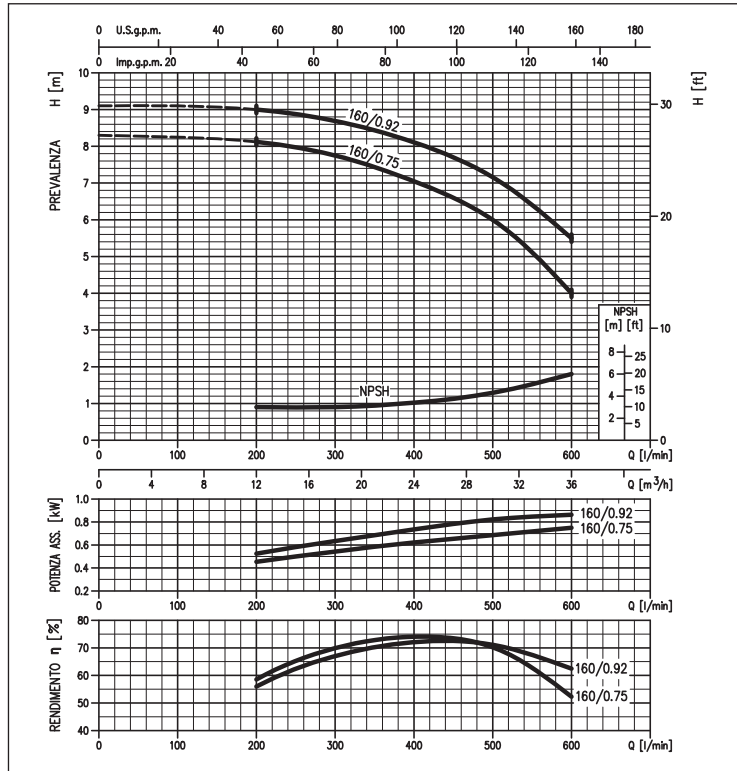

### CURVE DI PRESTAZIONE serie LPC4 65-200

(secondo ISO 9906 Allegato A)

4 Poli

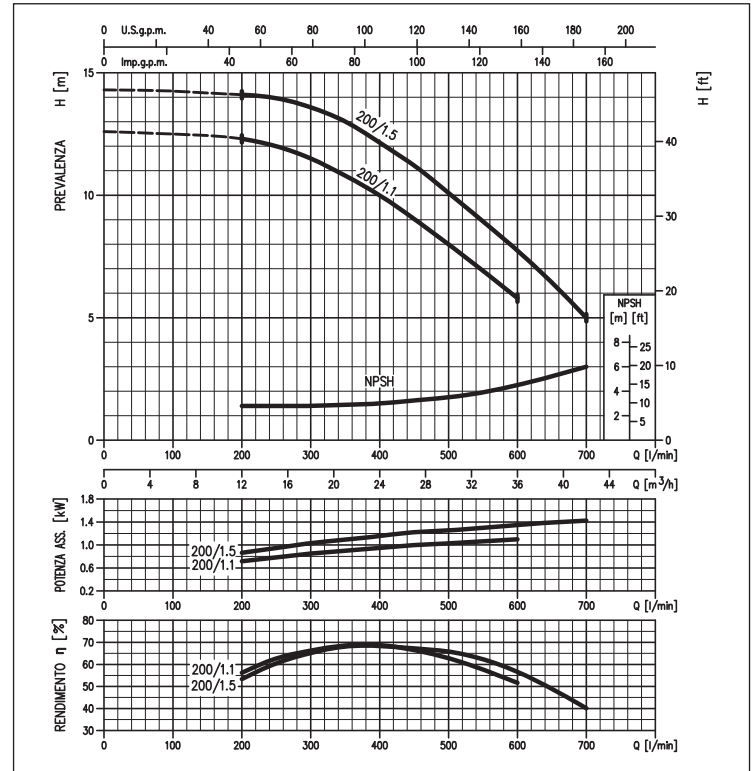

### CURVE DI PRESTAZIONE serie LPC4 80-160

(secondo ISO 9906 Allegato A)

4 Poli

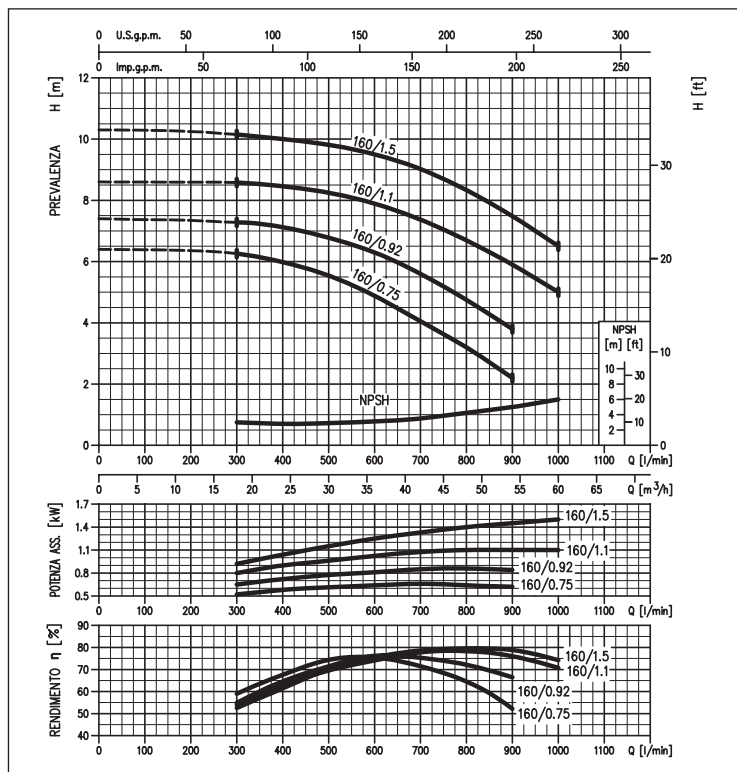

### CURVE DI PRESTAZIONE serie LPC4 80-200

(secondo ISO 9906 Allegato A)

4 Poli

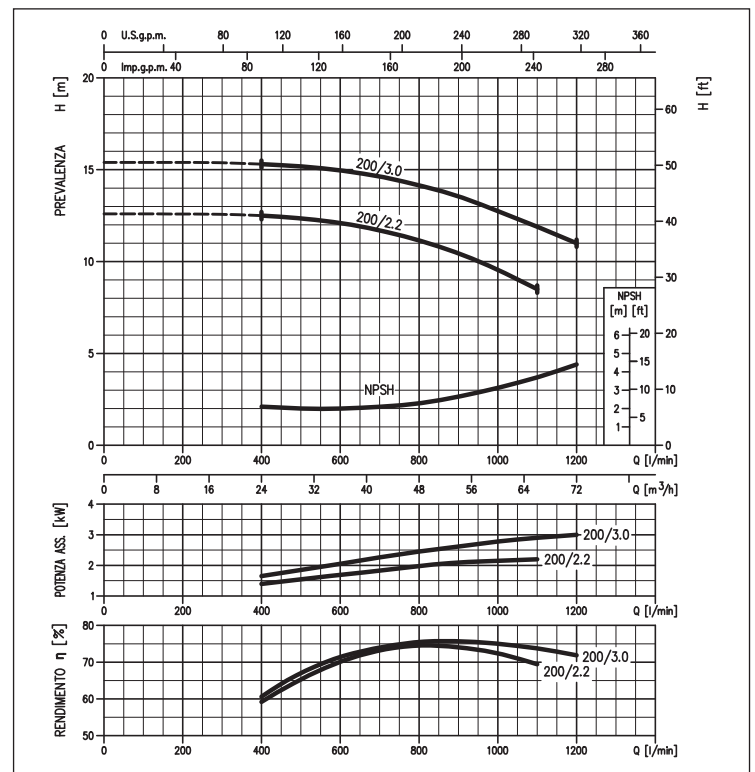

## ELETTROPOMPE CENTRIFUGHE IN-LINE

in ghisa

### CURVE DI PRESTAZIONE serie LPC4 100-160

(secondo ISO 9906 Allegato A)

4 Poli

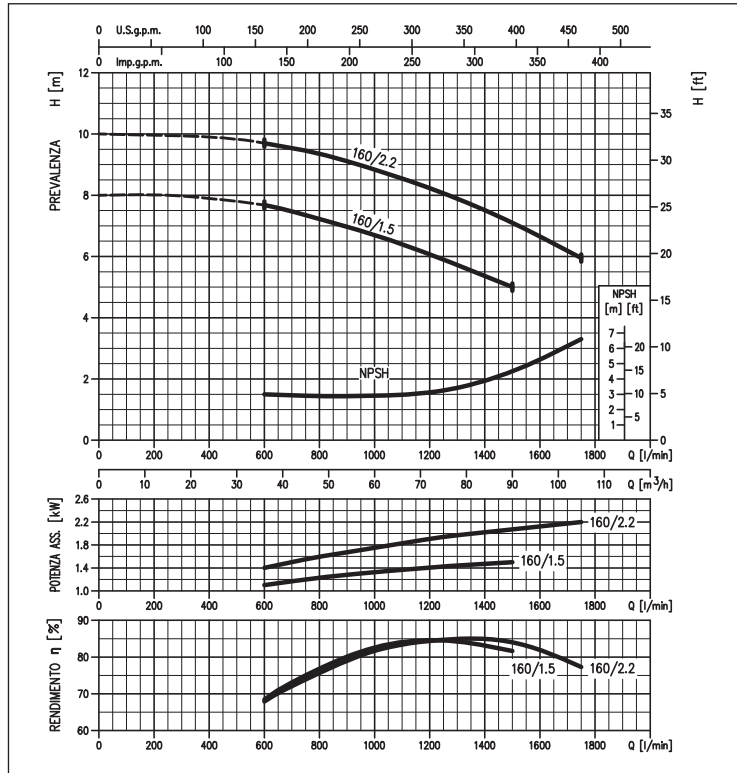

### CURVE DI PRESTAZIONE serie LPC4 100-200

(secondo ISO 9906 Allegato A)

4 Poli

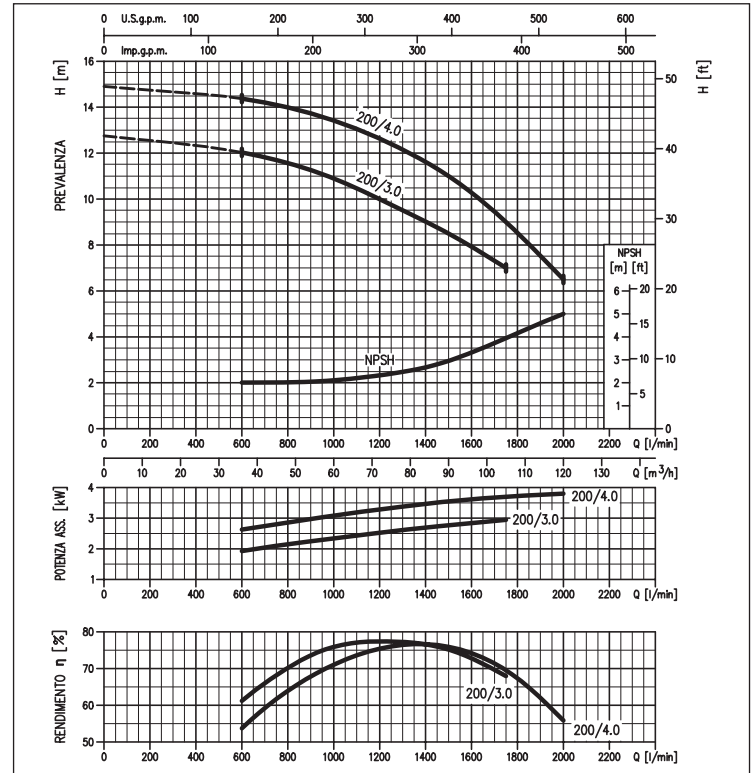

### CURVE DI PRESTAZIONE serie LPC4 100-250

(secondo ISO 9906 Allegato A)

4 Poli

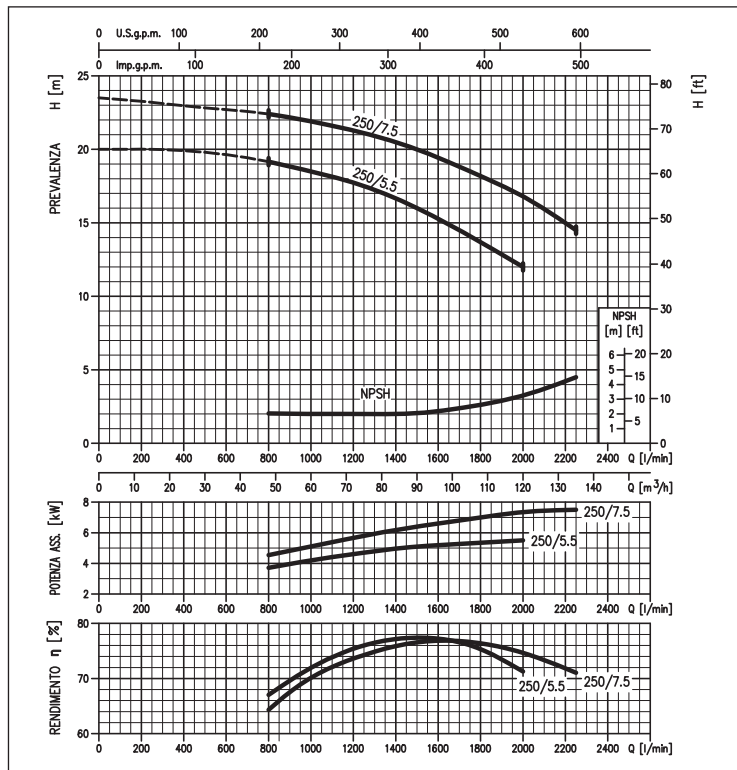

## ELETTROPOMPE CENTRIFUGHE IN-LINE

in ghisa

### CURVE DI PRESTAZIONE serie LPCD4 40-100/40-125

(secondo ISO 9906 Allegato A)

4 Poli

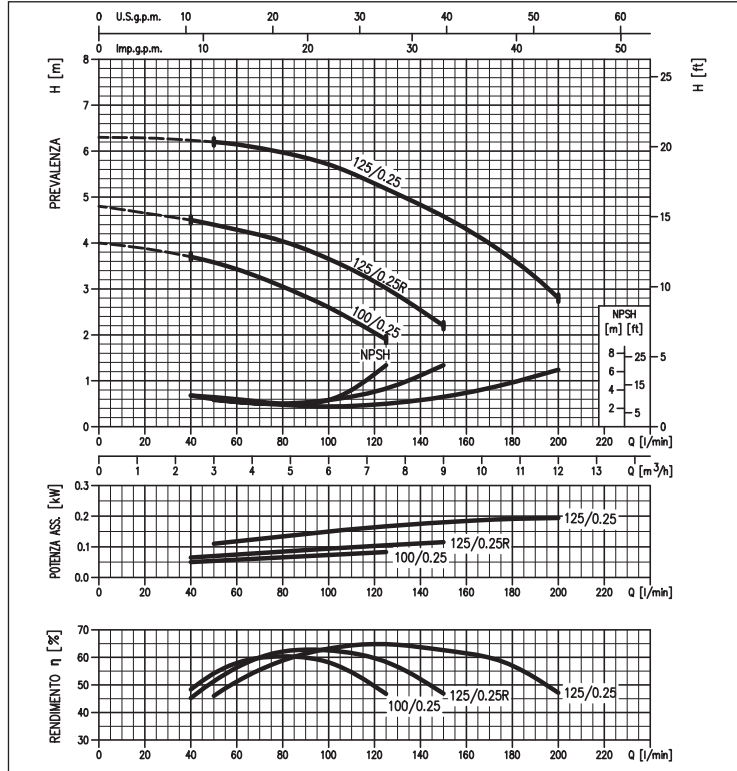

### CURVE DI PRESTAZIONE serie LPCD4 50-125

(secondo ISO 9906 Allegato A)

4 Poli

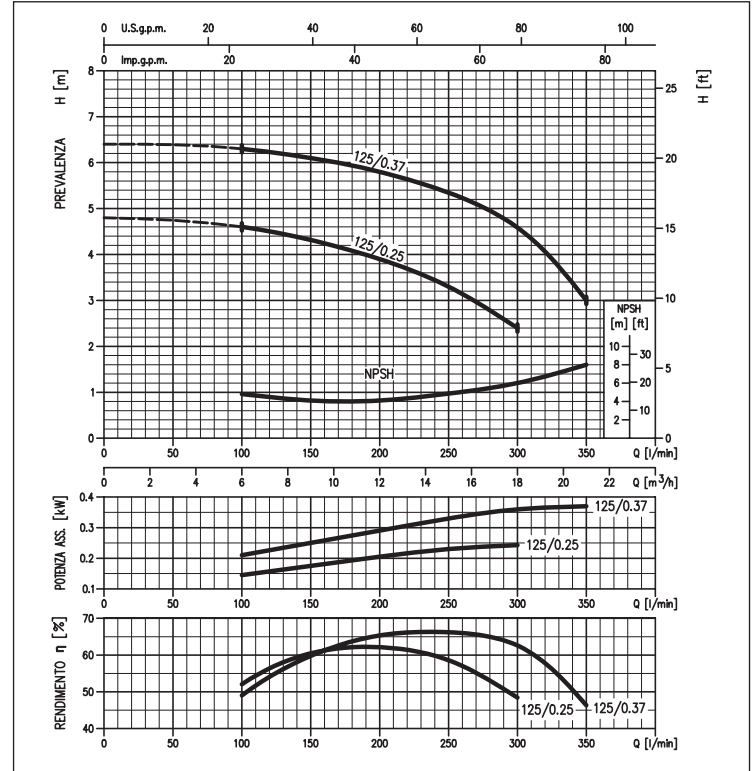

### CURVE DI PRESTAZIONE serie LPCD4 50-160

(secondo ISO 9906 Allegato A)

4 Poli

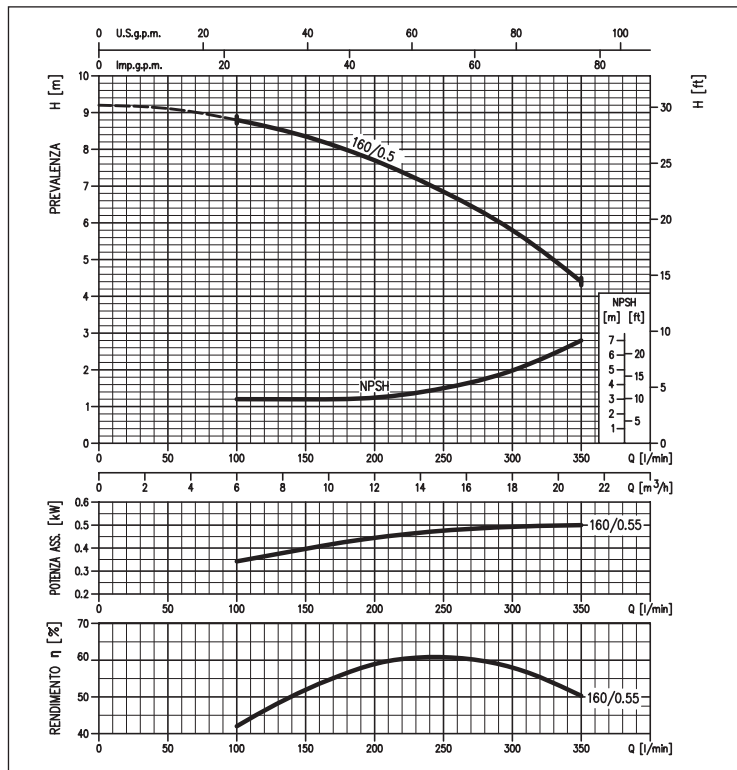

### CURVE DI PRESTAZIONE serie LPCD4 65-160

(secondo ISO 9906 Allegato A)

4 Poli

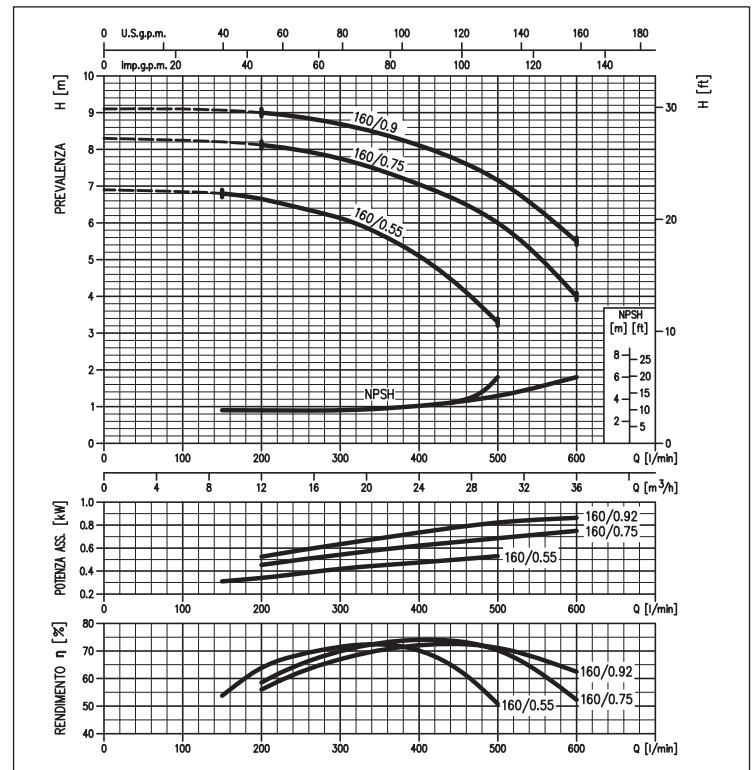

## ELETTROPOMPE CENTRIFUGHE IN-LINE

in ghisa

### CURVE DI PRESTAZIONE serie LPCD4 80-160

(secondo ISO 9906 Allegato A)

4 Poli

### CURVE DI PRESTAZIONE serie LPCD4 100-200

(secondo ISO 9906 Allegato A)

4 Poli

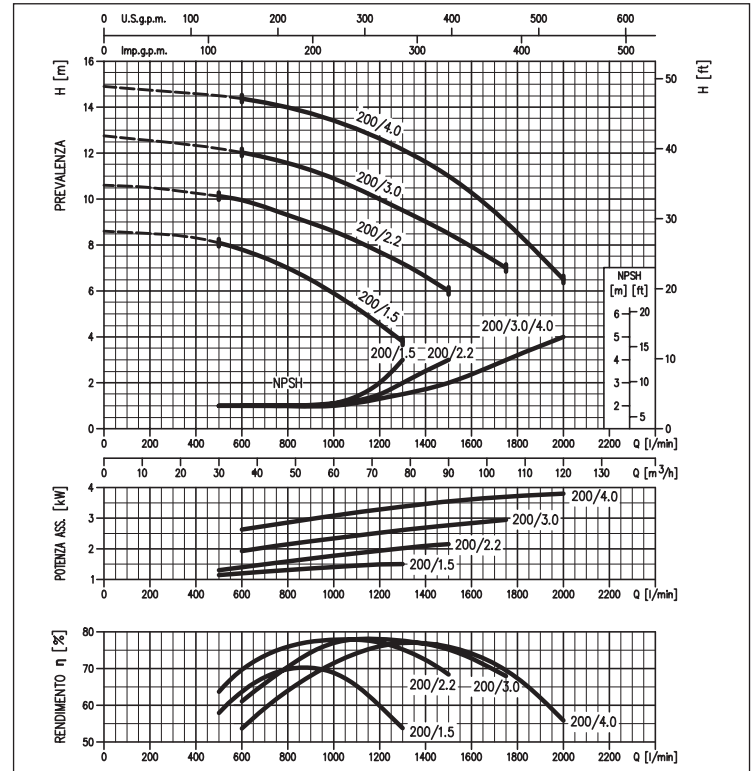
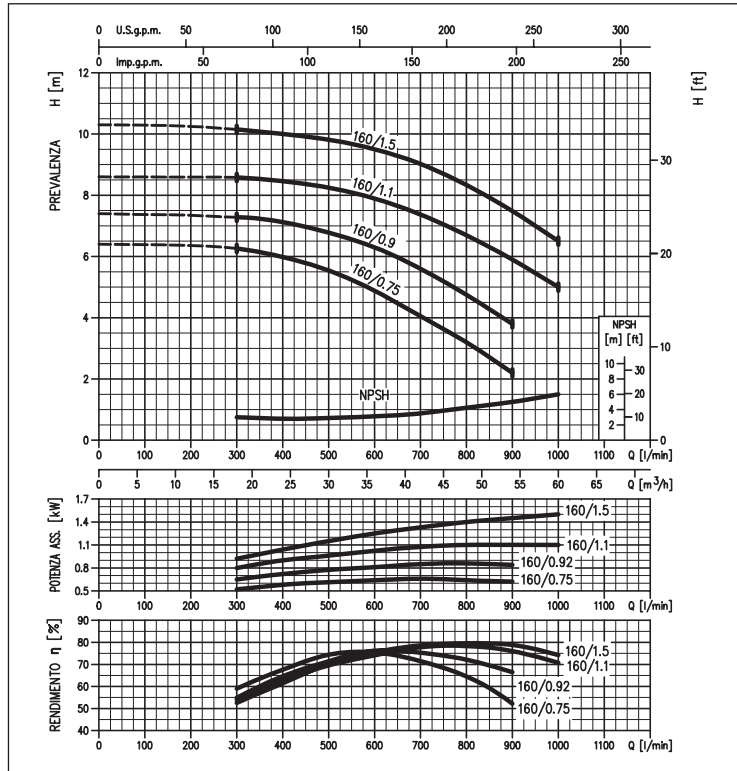

## ELETTROPOMPE CENTRIFUGHE IN-LINE

in ghisa

### DIMENSIONI LPC 40-50

2 Poli

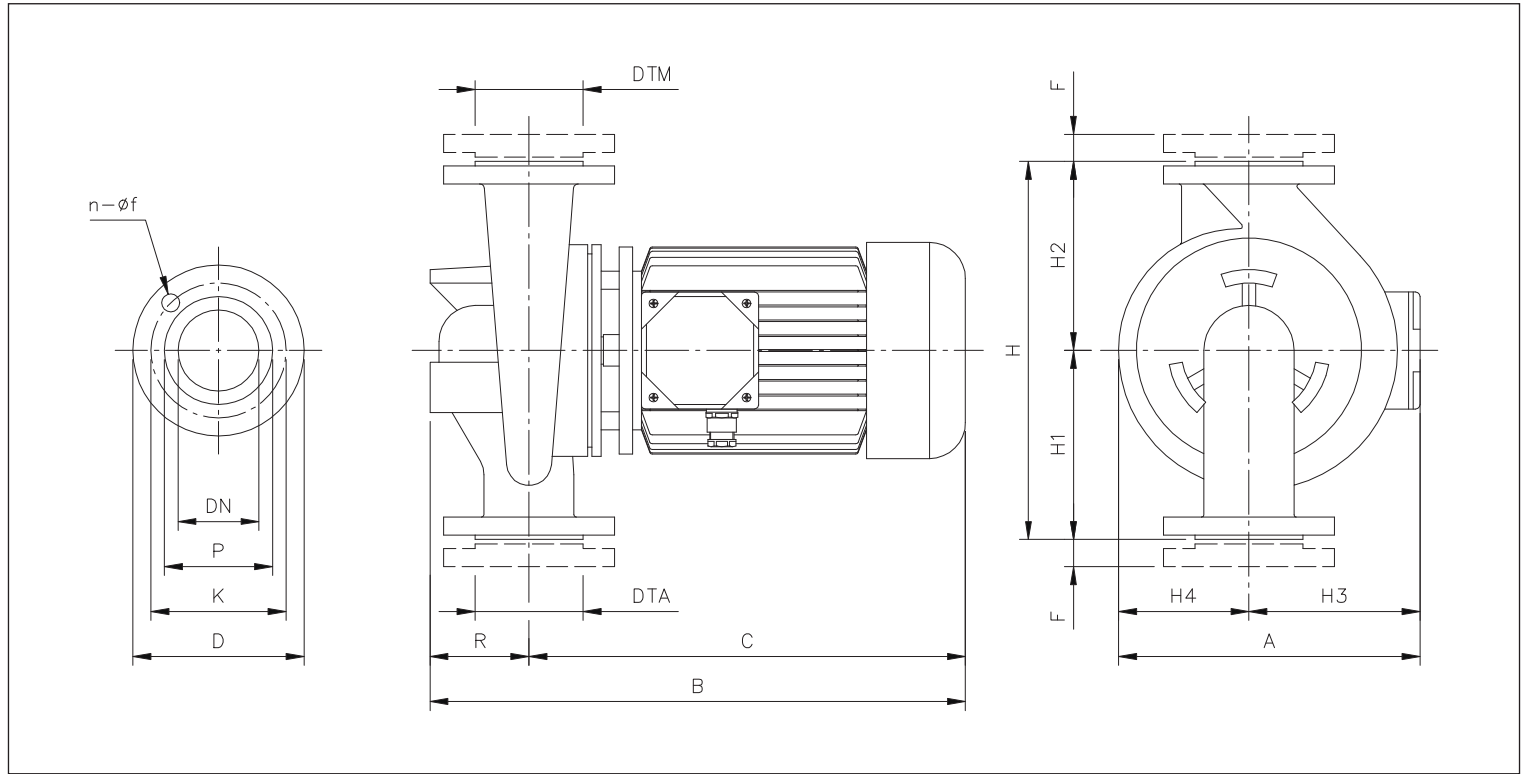

### TABELLA DIMENSIONI

Modello	Dimensioni [mm]																		Peso [kg]
	DTA/M	DNA/M	n	f	P	K	D	H	H1	H2	H3	H4	R	F	A	B	C		
LPC 32-100/0.37	G1¼	32PN6	4	14	70	90	120	220	110	110	107	65	65	16	172	395	330	12,0	
LPC 40-100/0.55	G1½	40PN6	4	14	80	100	130	240	140	120	107	77	90	16	184	445	335	16,0	
LPC 40-100/0.75	G1½	40PN6	4	14	80	100	130	240	140	120	107	77	90	16	184	445	335	16,0	
LPC 40-125/0.75	G1½	40PN10	4	18	88	110	150	300	160	140	107	93	100	20	200	425	325	24,0	
LPC 40-125/1.1	G1½	40PN10	4	18	88	110	150	300	160	140	118	93	100	20	211	445	345	25,0	
LPC 40-125/1.5	G1½	40PN10	4	18	88	110	150	300	160	140	118	93	100	20	211	445	345	26,0	
LPC 40-160/2.2	G1½	40PN10	4	18	88	110	150	320	170	150	118	108	100	20	226	445	345	30,0	
LPC 40-160/3 R	G1½	40PN10	4	18	88	110	150	320	170	150	149	108	100	20	257	485	385	35,0	
LPC 40-160/3	G1½	40PN10	4	18	88	110	150	320	170	150	149	108	100	20	257	485	385	35,0	
LPC 40-200/4	G1½	40PN10	4	18	88	110	150	380	200	180	159	127	100	20	286	525	425	50,0	
LPC 40-200/5.5	G1½	40PN10	4	18	88	110	150	380	200	180	159	127	100	20	286	535	435	55,0	
LPC 40-200/6.3	G1½	40PN10	4	18	88	110	150	380	200	180	159	127	100	20	286	535	435	56,0	
LPC 50-125/1.5	G2	50PN10	4	18	102	125	165	320	180	140	118	103	110	22	221	455	345	27,0	
LPC 50-125/2.2	G2	50PN10	4	18	102	125	165	320	180	140	118	103	110	22	221	455	345	28,0	
LPC 50-125/3	G2	50PN10	4	18	102	125	165	320	180	140	149	103	110	22	252	495	385	32,0	
LPC 50-160/3	G2	50PN10	4	18	102	125	165	340	180	160	149	113	110	22	262	495	385	32,0	
LPC 50-160/4	G2	50PN10	4	18	102	125	165	340	180	160	159	113	110	22	272	535	425	42,0	
LPC 50-200/5.5	G2	50PN10	4	18	102	125	165	400	220	180	159	131	110	22	290	545	435	56,0	
LPC 50-200/6.3	G2	50PN10	4	18	102	125	165	400	220	180	159	131	110	22	290	545	435	57,0	
LPC 50-200/7.5	G2	50PN10	4	18	102	125	165	400	220	180	184	131	110	22	315	650	540	64,0	

### DIMENSIONI LPC 65-80-100

2 Poli

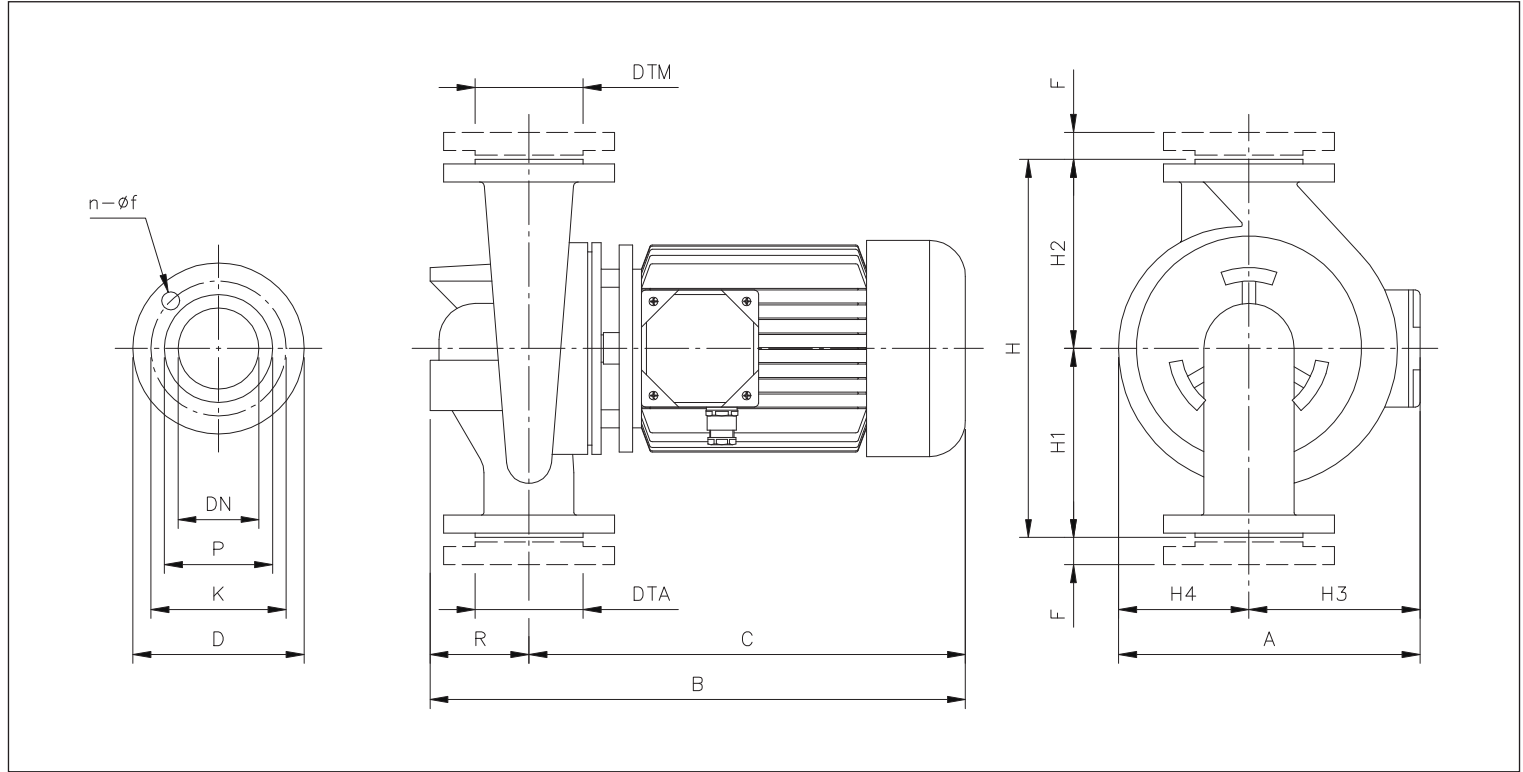

### TABELLA DIMENSIONI

Modello	Dimensioni [mm]																		Peso [kg]
	DTA/M	DNA/M	n	f	P	K	D	H	H1	H2	H3	H4	R	F	A	B	C		
LPC 65-125/2.2	G2½	65PN10	4	18	122	145	185	360	205	155	118	108	140	22	226	485	345	32,0	
LPC 65-125/3.0	G2½	65PN10	4	18	122	145	185	360	205	155	149	108	140	22	257	525	385	39,0	
LPC 65-125/4.0	G2½	65PN10	4	18	122	145	185	360	205	155	159	108	140	22	267	565	425	43,0	
LPC 65-160/5.5	G2½	65PN10	4	18	122	145	185	400	220	180	159	122	140	22	281	575	435	54,0	
LPC 65-160/7.5	G2½	65PN10	4	18	122	145	185	400	220	180	184	122	140	22	306	680	540	61,0	
LPC 65-200/10	G2½	65PN10	4	18	122	145	185	440	240	200	184	136	140	22	320	680	540	70,0	
LPC 65-200/12.5	G2½	65PN10	4	18	122	145	185	440	240	200	184	136	140	22	320	680	540	77,0	
LPC 80-160/10	G3	80PN10	8	18	138	160	200	440	240	200	184	131	160	24	315	700	540	72,0	
LPC 80-160/12.5	G3	80PN10	8	18	138	160	200	440	240	200	184	131	160	24	315	700	540	79,0	
LPC 80-160/15	G3	80PN10	8	18	138	160	200	440	240	200	184	131	160	24	315	700	540	85,0	
LPC 80-200/15	G3	80PN10	8	18	138	160	200	500	275	225	184	146	160	24	330	700	540	91,0	
LPC 80-200/18.5	G3	80PN10	8	18	138	160	200	500	275	225	229	146	160	24	375	860	700	124,0	
LPC 80-200/22	G3	80PN10	8	18	138	160	200	500	275	225	229	146	160	24	375	860	700	142,0	
LPC 100-160/10	G4	100PN10	8	18	158	180	220	525	300	225	184	136	190	26	320	730	540	76,0	
LPC 100-160/12.5	G4	100PN10	8	18	158	180	220	525	300	225	184	136	190	26	320	730	540	84,0	
LPC 100-160/15	G4	100PN10	8	18	158	180	220	525	300	225	184	136	190	26	320	730	540	91,0	
LPC 100-200/18.5	G4	100PN10	8	18	158	180	220	550	300	250	230	156	190	26	386	890	710	135,0	
LPC 100-200/22	G4	100PN10	8	18	158	180	220	550	300	250	230	156	190	26	386	890	710	153,0	
LPC 100-200/30	G4	100PN10	8	18	158	180	220	550	300	250	257	156	190	26	413	995	805	195,0	
LPC 100-200/37	G4	100PN10	8	18	158	180	220	550	300	250	257	156	190	26	413	995	805	213,0	
LPC 100-250/37	G4	100PN10	8	18	158	180	220	600	320	280	257	176	190	26	433	995	805	220,0	

## ELETTROPOMPE CENTRIFUGHE IN-LINE

in ghisa

### DIMENSIONI LPCD 40-50-65-80-100

2 Poli

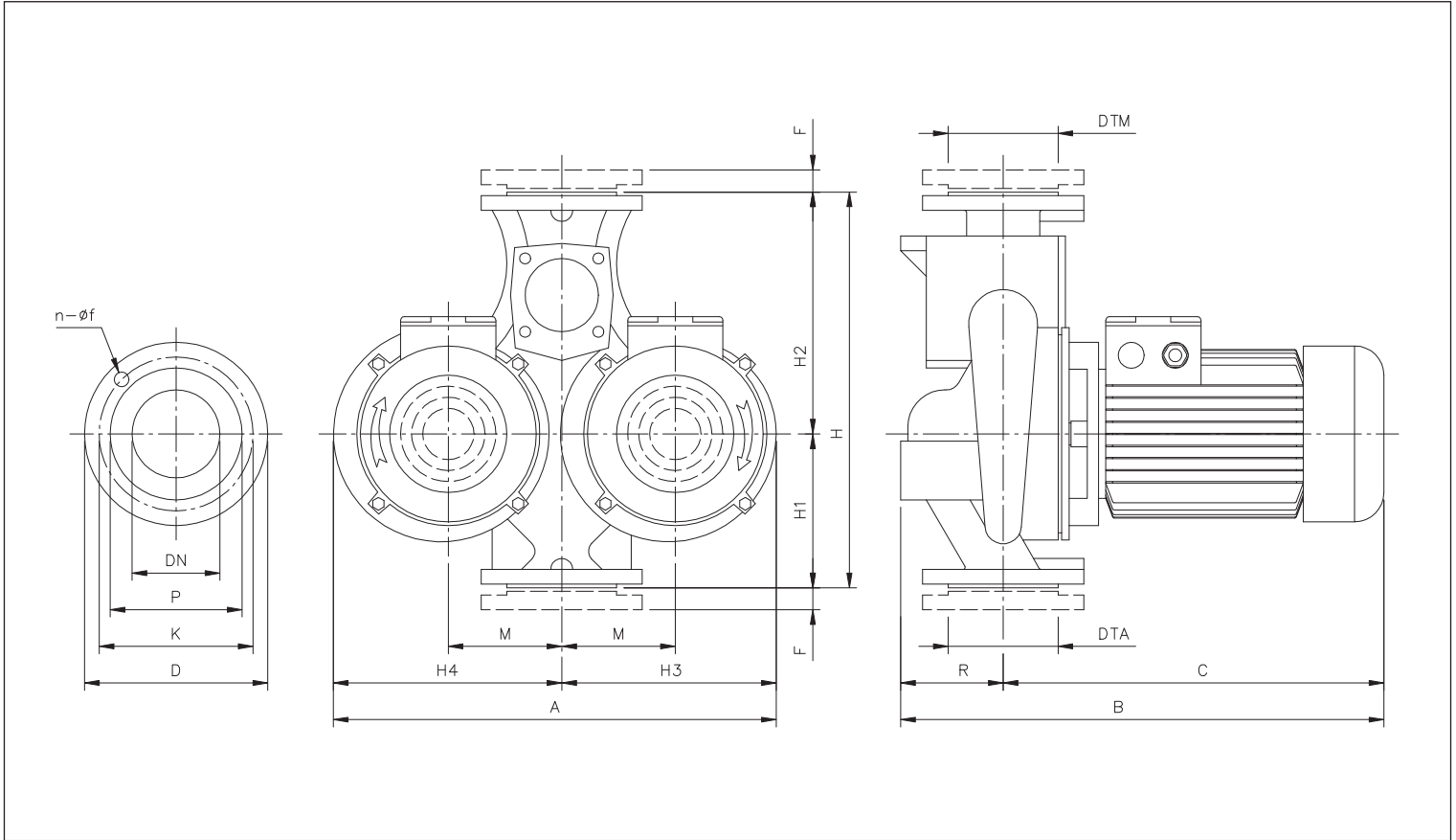

### TABELLA DIMENSIONI

Modello	Dimensioni [mm]																			Peso [kg]
	DTA/M	DNA/M	n	f	P	K	D	H4	H1	H2	H3	H4	M	R	F	A	B	C		
LPCD 40-125/0.55	G1½	40PN10	4	18	88	110	150	340	130	210	197	200	100	100	20	397	425	325	50,0	
LPCD 40-125/0.75	G1½	40PN10	4	18	88	110	150	340	130	210	197	200	100	100	20	397	425	325	50,0	
LPCD 40-125/1.1	G1½	40PN10	4	18	88	110	150	340	130	210	197	200	100	100	20	397	445	345	52,0	
LPCD 40-125/1.5	G1½	40PN10	4	18	88	110	150	340	130	210	197	200	100	100	20	397	445	345	54,0	
LPCD 50-125/1.5	G2	50PN10	4	18	102	125	165	365	145	220	210	217	105	110	22	427	455	345	56,0	
LPCD 50-125/2.2	G2	50PN10	4	18	102	125	165	365	145	220	210	217	105	110	22	427	455	345	58,0	
LPCD 50-125/3.0	G2	50PN10	4	18	102	125	165	365	145	220	210	217	105	110	22	427	495	385	66,0	
LPCD 50-160/3.0	G2	50PN10	4	18	102	125	165	410	170	240	235	245	120	110	22	480	495	385	72,0	
LPCD 50-160/4.0	G2	50PN10	4	18	102	125	165	410	170	240	235	245	120	110	22	480	535	425	86,0	
LPCD 65-160/3.0	G2½	65PN10	4	18	122	145	185	450	180	270	268	275	140	130	22	543	515	385	81,0	
LPCD 65-160/4.0	G2½	65PN10	4	18	122	145	185	450	180	270	268	275	140	130	22	543	555	425	101,0	
LPCD 65-160/5.5	G2½	65PN10	4	18	122	145	185	450	180	270	268	275	140	130	22	543	565	435	125,0	
LPCD 65-160/7.5	G2½	65PN10	4	18	122	145	185	450	180	270	268	275	140	130	22	543	565	435	132,0	
LPCD 80-160/7.5	G3	80PN10	8	18	138	160	200	510	205	305	270	280	135	130	24	550	565	435	137,0	
LPCD 80-160/10	G3	80PN10	8	18	138	160	200	510	205	305	270	280	135	150	24	550	690	540	141,0	
LPCD 80-160/12.5	G3	80PN10	8	18	138	160	200	510	205	305	270	280	135	150	24	550	690	540	162,0	
LPCD 80-160/15	G3	80PN10	8	18	138	160	200	510	205	305	270	280	135	150	24	550	690	540	175,0	
LPCD 100-200/10	G4	100PN10	8	18	158	180	220	630	240	390	345	325	165	180	26	670	720	540	200,0	
LPCD 100-200/12.5 R	G4	100PN10	8	18	158	180	220	630	240	390	345	325	165	180	26	670	720	540	230,0	
LPCD 100-200/12.5	G4	100PN10	8	18	158	180	220	630	240	390	345	325	165	180	26	670	720	540	162,0	
LPCD 100-200/15 R	G4	100PN10	8	18	158	180	220	630	240	390	345	325	165	180	26	670	720	540	214,0	
LPCD 100-200/15	G4	100PN10	8	18	158	180	220	630	240	390	345	325	165	180	26	670	720	540	162,0	

## ELETTROPOMPE CENTRIFUGHE IN-LINE

in ghisa

4 Poli

### DIMENSIONI LPC4 40-50-65-80-100

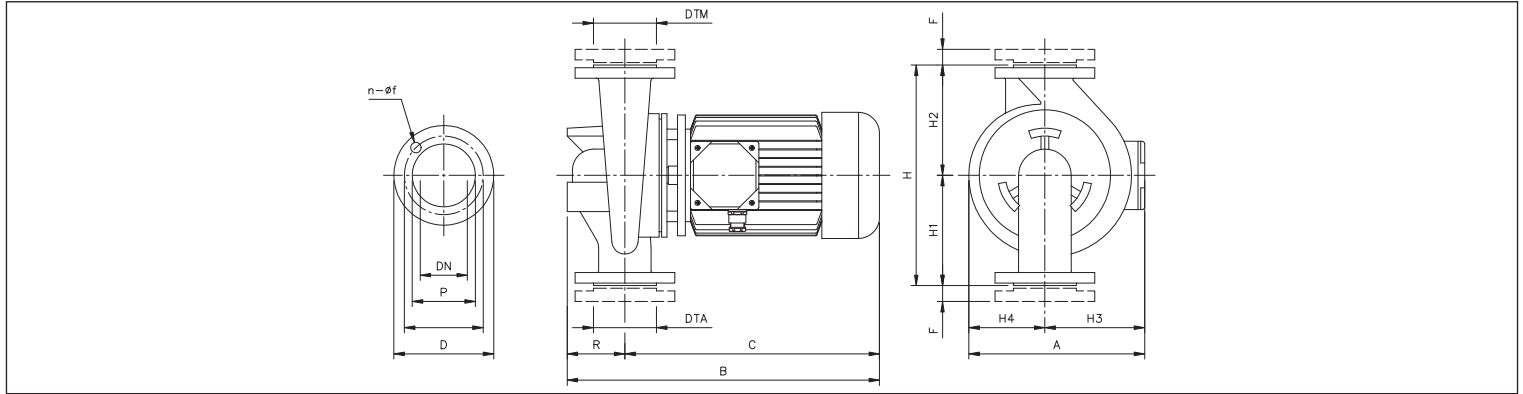

### TABELLA DIMENSIONI

Modello	Dimensioni [mm]																		Peso [kg]
	DTA/M	DNA/M	n	f	P	K	D	H	H1	H2	H3	H4	R	F	A	B	C		
LPC4 32-100/0.25	G1½	32PN6	4	14	70	90	120	220	110	110	107	65	65	16	172	395	330	12,0	
LPC4 40-100/0.25	G1½	40PN6	4	14	80	100	130	260	140	120	107	77	90	16	184	445	355	16,0	
LPC4 40-125/0.25 R	G1½	40PN10	4	18	88	110	150	300	160	140	107	93	100	20	200	425	325	20,0	
LPC4 40-125/0.25	G1½	40PN10	4	18	88	110	150	300	160	140	107	93	100	20	200	425	325	20,0	
LPC4 40-160/0.37	G1½	40PN10	4	18	88	110	150	320	170	150	107	108	100	20	215	425	325	23,0	
LPC4 40-200/0.75	G1½	40PN10	4	18	88	110	150	380	200	180	118	127	100	20	245	445	345	30,0	
LPC4 40-200/0.92	G1½	40PN10	4	18	88	110	150	380	200	180	118	127	100	20	245	445	345	31,0	
LPC4 40-250/1.1	G1½	40PN10	4	18	88	110	150	440	230	210	165	165	100	20	330	485	385	51,0	
LPC4 40-250/1.5	G1½	40PN10	4	18	88	110	150	440	230	210	165	165	100	20	330	485	385	51,0	
LPC4 50-125/0.25	G2	50PN10	4	18	102	125	165	320	180	140	107	103	110	22	210	435	325	21,0	
LPC4 50-125/0.37	G2	50PN10	4	18	102	125	165	320	180	140	107	103	110	22	210	435	325	22,0	
LPC4 50-160/0.55	G2	50PN10	4	18	102	125	165	340	180	160	107	113	110	22	220	435	325	25,0	
LPC4 50-200/1.1 R	G2	50PN10	4	18	102	125	165	400	220	180	149	131	110	22	280	495	385	36,0	
LPC4 50-200/1.1	G2	50PN10	4	18	102	125	165	400	220	180	149	131	110	22	280	495	385	36,0	
LPC4 50-250/1.5	G2	50PN10	4	18	102	125	165	440	230	210	165	165	125	22	330	510	385	52,0	
LPC4 50-250/2.2	G2	50PN10	4	18	102	125	165	440	230	210	165	165	125	22	330	550	425	56,0	
LPC4 65-125/0.37	G2½	65PN10	4	18	122	145	185	360	205	155	107	108	140	22	215	465	325	25,0	
LPC4 65-125/0.55	G2½	65PN10	4	18	122	145	185	360	205	155	107	108	140	22	215	465	325	26,0	
LPC4 65-160/0.75	G2½	65PN10	4	18	122	145	185	400	220	180	118	122	140	22	240	485	345	32,0	
LPC4 65-160/0.92	G2½	65PN10	4	18	122	145	185	400	220	180	118	122	140	22	240	485	345	33,0	
LPC4 65-200/1.1	G2½	65PN10	4	18	122	145	185	440	240	200	149	136	140	22	285	525	385	38,0	
LPC4 65-200/1.5	G2½	65PN10	4	18	122	145	185	440	240	200	149	136	140	22	285	525	385	40,0	
LPC4 65-250/2.2	G2½	65PN10	4	18	122	145	185	475	250	225	170	165	140	22	335	565	425	66,0	
LPC4 65-250/3	G2½	65PN10	4	18	122	145	185	475	250	225	170	165	140	22	335	565	425	66,0	
LPC4 80-160/0.75	G3	80PN10	8	18	138	160	200	440	240	200	118	131	160	24	249	505	345	36,0	
LPC4 80-160/0.92	G3	80PN10	8	18	138	160	200	440	240	200	118	131	160	24	249	505	345	37,0	
LPC4 80-160/1.1	G3	80PN10	8	18	138	160	200	440	240	200	149	131	160	24	280	545	385	38,0	
LPC4 80-160/1.5	G3	80PN10	8	18	138	160	200	440	240	200	149	131	160	24	280	545	385	40,0	
LPC4 80-200/2.2	G3	80PN10	8	18	138	160	200	500	275	225	159	146	160	24	305	585	425	51,0	
LPC4 80-200/3.0	G3	80PN10	8	18	138	160	200	500	275	225	159	146	160	24	305	585	425	57,0	
LPC4 80-250/4	G3	80PN10	8	18	138	160	200	530	280	250	185	168	160	24	353	700	540	84,0	
LPC4 80-250/5.5	G3	80PN10	8	18	138	160	200	530	280	250	185	168	160	24	353	700	540	94,0	
LPC4 100-160/1.5	G4	100PN10	8	18	158	180	220	525	300	225	149	136	190	26	285	575	385	45,0	
LPC4 100-160/2.2	G4	100PN10	8	18	158	180	220	525	300	225	159	136	190	26	295	615	425	50,0	
LPC4 100-200/3.0	G4	100PN10	8	18	158	180	220	550	300	250	159	156	190	26	315	615	425	66,0	
LPC4 100-200/4.0	G4	100PN10	8	18	158	180	220	550	300	250	159	156	190	26	315	625	435	73,0	
LPC4 100-250/5.5	G4	100PN10	8	18	158	180	220	600	320	280	184	176	190	26	360	730	540	96,0	
LPC4 100-250/7.5	G4	100PN10	8	18	158	180	220	600	320	280	184	176	190	26	360	730	540	106,0	
LPC4 125-250/5.5 R	G5	125PN16	8	18	188	210	250	620	340	280	220	195	195	28	415	745	550	132,0	
LPC4 125-250/5.5	G5	125PN16	8	18	188	210	250	620	340	280	220	195	195	28	415	745	550	132,0	
LPC4 125-250/7.5	G5	125PN16	8	18	188	210	250	620	340	280	220	195	195	28	415	745	550	135,0	
LPC4 125-250/9.2	G5	125PN16	8	18	188	210	250	620	340	280	220	195	195	28	415	745	550	138,0	
LPC4 150-250/7.5	G6	150PN16	8	22	212	240	285	700	370	330	250	210	220	28	460	775	555	154,0	
LPC4 150-250/9.2	G6	150PN16	8	22	212	240	285	700	370	330	250	210	220	28	460	775	555	158,0	
LPC4 150-250/11	G6	150PN16	8	22	212	240	285	700	370	330	250	210	220	28	460	775	555	162,0	
LPC4 150-250/15 R	G6	150PN16	8	22	212	240	285	700	370	330	300	210	220	28	510	975	755	201,0	
LPC4 150-250/15	G6	150PN16	8	22	212	240	285	700	370	330	300	210	220	28	510	975	755	201,0	

## ELETTROPOMPE CENTRIFUGHE IN-LINE

in ghisa

DIMENSIONI LPCD4 40-50-65-80-100

4 Poli



TABELLA DIMENSIONI

Modello	Dimensioni [mm]																			Peso [kg]
	DTA/M	DNA/M	n	f	P	K	D	H	H1	H2	H3	H4	M	R	F	A	B	C		
LPCD4 40-100/0.25	G1½	40PN10	4	18	88	110	150	340	130	210	197	200	100	100	20	397	425	325	41	
LPCD4 40-125/0.25R	G1½	40PN10	4	18	88	110	150	340	130	210	197	200	100	100	20	397	425	325	41	
LPCD4 40-125/0.25	G1½	40PN10	4	18	88	110	150	340	130	210	197	200	100	100	20	397	425	325	41	
LPCD4 50-125/0.25	G2	50PN10	4	18	102	125	165	365	145	220	210	217	105	110	22	427	435	325	44	
LPCD4 50-125/0.37	G2	50PN10	4	18	102	125	165	365	145	220	210	217	105	110	22	427	435	325	46	
LPCD4 50-160/0.55	G2	50PN10	4	18	102	125	165	410	170	240	235	245	120	110	22	480	435	325	52	
LPCD4 65-160/0.55	G2½	65PN10	4	18	122	145	185	450	180	270	268	275	140	130	22	543	475	345	65	
LPCD4 65-160/0.75	G2½	65PN10	4	18	122	145	185	450	180	270	268	275	140	130	22	543	475	345	65	
LPCD4 65-160/0.92	G2½	65PN10	4	18	122	145	185	450	180	270	268	275	140	130	22	543	475	345	67	
LPCD4 80-160/0.75	G3	80PN10	8	18	138	160	200	510	205	305	270	280	135	150	24	550	485	335	72	
LPCD4 80-160/0.92	G3	80PN10	8	18	138	160	200	510	205	305	270	280	135	150	24	550	485	335	74	
LPCD4 80-160/1.1	G3	80PN10	8	18	138	160	200	510	205	305	270	280	135	150	24	550	535	385	79	
LPCD4 80-160/1.5	G3	80PN10	8	18	138	160	200	510	205	305	270	280	135	150	24	550	535	385	83	
LPCD4 100-200/1.5	G4	100PN10	8	18	158	180	220	630	240	390	345	325	165	180	26	670	535	355	110	
LPCD4 100-200/2.2	G4	100PN10	8	18	158	180	220	630	240	390	345	325	165	180	26	670	605	425	130	
LPCD4 100-200/3.0	G4	100PN10	8	18	158	180	220	630	240	390	345	325	165	180	26	670	605	425	138	
LPCD4 100-200/4.0	G4	100PN10	8	18	158	180	220	630	240	390	345	325	165	180	26	670	615	435	150	

## ELETTROPOMPE CENTRIFUGHE IN-LINE

in ghisa

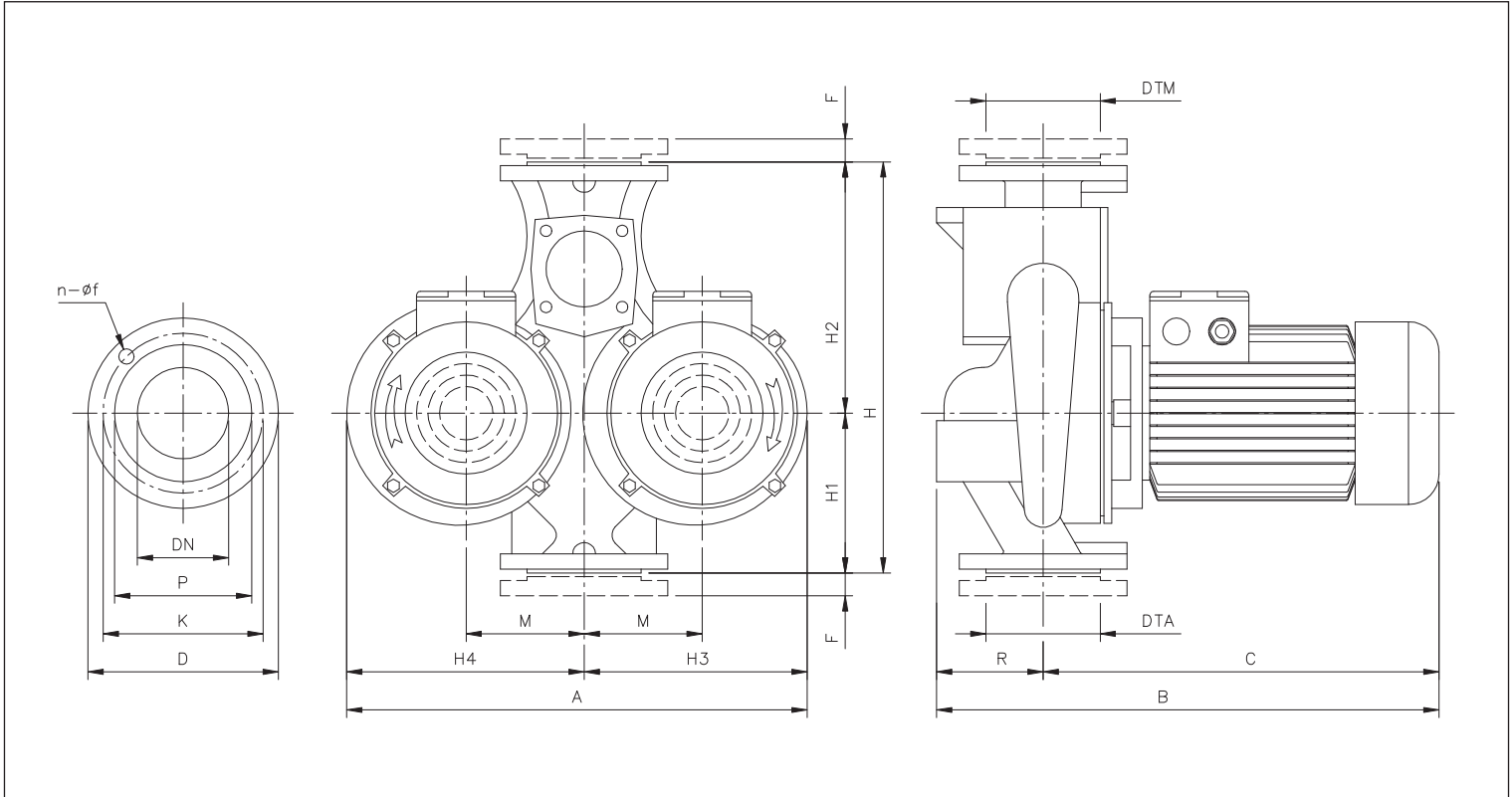
### VISTA IN SEZIONE LPC - LPC4

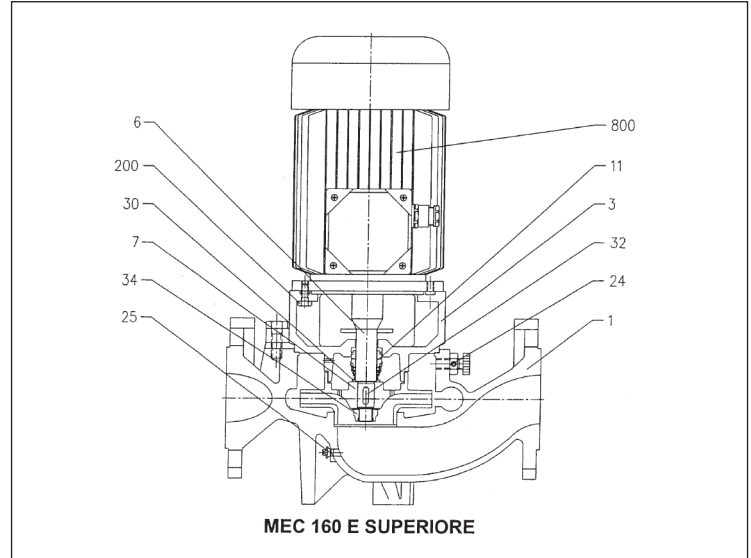
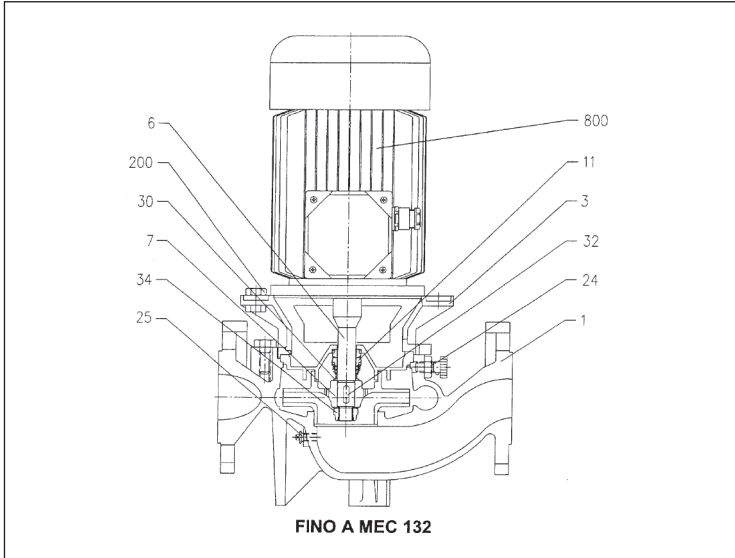

### TABELLA MATERIALI

Rif.	Nome	Materiale	Rif.	Nome	Materiale
1	Corpo pompa	Ghisa G 20	25	Tappo scarico	Acciaio inox
3	Supporto motore	Ghisa	30	Distanziale	Acciaio inox
6	Albero	AISI 420	32	Linguetta	Acciaio inox
7	Girante	Ghisa	34	Dado girante	Acciaio inox
11	Tenuta meccanica	Carbone/SiC/EPDM	200	Vite (corpo pompa)	Acciaio inox
24	Tappo carico	Acciaio inox			

### VISTA IN SEZIONE LPCD - LPCD4

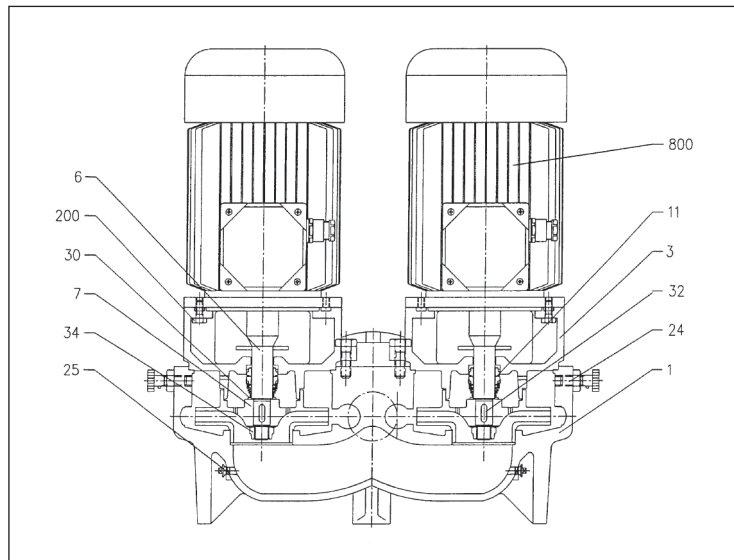

### TABELLA MATERIALI

Rif.	Nome	Materiale	Rif.	Nome	Materiale
1	Corpo pompa	Ghisa G 20	25	Tappo scarico	Acciaio inox
3	Supporto motore	Ghisa	30	Distanziale	Acciaio inox
6	Albero	AISI 420	32	Linguetta	Acciaio inox
7	Girante	Ghisa	34	Dado girante	Acciaio inox
11	Tenuta meccanica	Carbone/SiC/EPDM	200	Vite (corpo pompa)	Acciaio inox
24	Tappo carico	Acciaio inox			

## ELETTROPOMPE CENTRIFUGHE IN-LINE

in ghisa

### TENUTA MECCANICA

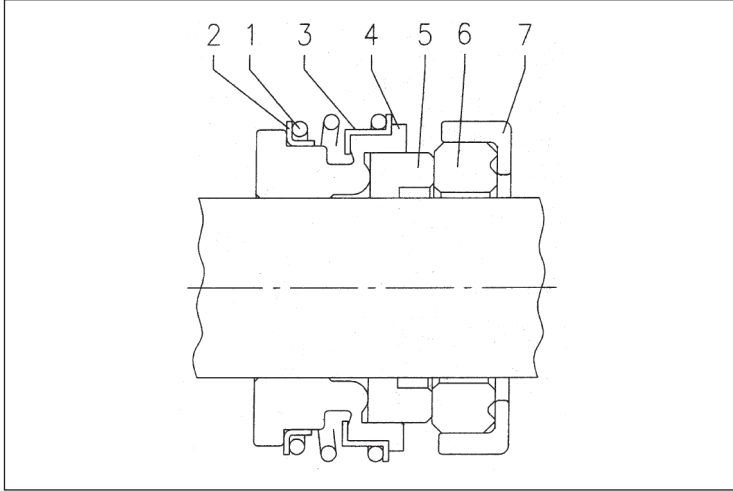

### TABELLA MATERIALI

Rif.	Nome	Materiale	
		Standard Max. temperatura: 110°C	Optional Max. temperatura: 90°C
1	Molla	AISI 316	AISI 316
2	Anello OR	EPDM	NBR
3	Struttura/telaio	AISI 316	AISI 316
4	Anello OR	EPDM	EPDM
5	Parte rotante	Carbone	SiC
6	Parte fissa	SiC	SiC
7	Coperchio in gomma	EPDM	EPDM

### TABELLA DATI ELETTRICI LPC

2 Poli

Modello	P <sub>2</sub>		Corrente assorbita [A]		
	[HP]	[kW]	230V	400V	690V
	LPC 40-100/0.55	0,75	0,55	2,8	1,6
LPC 40-100/0.75	1	0,75	3,3	1,9	-
LPC 40-125/0.75	1	0,75	3,3	1,9	-
LPC 40-125/1.1	1,5	1,1	1	1,35	-
LPC 40-125/1.5	2	1,5	6,2	3,6	-
LPC 40-160/2.2	3	2,2	7,7	4,4	-
LPC 40-160/3.0	4	3	11	6,4	-
LPC 40-160/4.0	5,5	4	16,2	8,8	-
LPC 40-200/4.0	5,5	4	16,2	8,8	-
LPC 40-200/5.5	7,5	5,5	-	11,3	6,5
LPC 40-200/6.3	8,5	6,3	-	12,8	7,4
LPC 50-125/1.5	2	1,5	6,2	3,6	-
LPC 50-125/2.2	3	2,2	7,7	4,4	-
LPC 50-125/3.0	4	3	11	6,4	-
LPC 50-160/3.0	4	3	11	6,4	-
LPC 50-160/4.0	5,5	4	16,2	8,8	-
LPC 50-200/5.5	7,5	5,5	-	11,3	6,5
LPC 50-200/6.3	8,5	6,3	-	12,8	7,4
LPC 50-200/7.5	10	7,5	-	17,3	10,0
LPC 65-125/2.2	3	2,2	7,7	4,4	-
LPC 65-125/3.0	4	3	11	6,4	-
LPC 65-125/4.0	5,5	4	16,2	8,8	-
LPC 65-160/5.5	7,5	5,5	-	11,3	6,5
LPC 65-160/7.5	10	7,5	-	17,3	10,0
LPC 65-200/10	13,6	10	-	22,5	13,0
LPC 65-200/12.5	17	12,5	-	27	15,5
LPC 80-160/10	13,6	10	-	22,5	13,0
LPC 80-160/12.5	17	12,5	-	27	15,5
LPC 80-160/15	20	15	-	32	18,5
LPC 80-200/15	20	15	-	32	18,5
LPC 80-200/18.5	25	18,5	-	38	22,0
LPC 80-200/22	30	22	-	44,5	25,7
LPC 100-160/10	13,6	10	-	22,5	13,0
LPC 100-160/12.5	17	12,5	-	27	15,5
LPC 100-160/15	20	15	-	32	18,5
LPC 100-200/18.5	25	18,5	-	38	22,0
LPC 100-200/22	30	22	-	44,5	25,7
LPC 100-200/30	40	30	-	68	29,2
LPC 100-200/37	55	37	-	71	41,0
LPC 100-250/37	55	37	-	71	41,0

## ELETTROPOMPE CENTRIFUGHE IN-LINE

in ghisa

**TABELLA DATI ELETTRICI LPCD**

**2 Poli**

Modello	P <sub>2</sub>		Corrente assorbita [A]		
	[HP]	[kW]	230V	400V	690V
LPCD 40-125/0.55	0,75	0,55	2,8	1,6	-
LPCD 40-125/0.75	1	0,75	3,3	1,9	-
LPCD 40-125/1.1	1,5	1,1	1	1,35	-
LPCD 40-125/1.5	2	1,5	6,2	3,6	-
LPCD 50-125/1.5	2	1,5	6,2	3,6	-
LPCD 50-125/2.2	3	2,2	7,7	4,4	-
LPCD 50-125/3.0	4	3	11	6,4	-
LPCD 50-160/3.0	4	3	11	6,4	-
LPCD 50-160/4.0	5,5	4	16,2	8,8	-
LPCD 65-160/3.0	4	3	11	6,4	-
LPCD 65-160/4.0	5,5	4	16,2	8,8	-
LPCD 65-160/5.5	7,5	5,5	-	11,3	6,5
LPCD 65-160/7.5	10	7,5	-	17,3	10,0
LPCD 80-160/7.5	10	7,5	-	17,3	10,0
LPCD 80-160/10	13,6	10	-	22,5	13,0
LPCD 80-160/12.5	17	12,5	-	27	15,5
LPCD 80-160/15	20	15	-	32	18,5
LPCD 100-200/12.5	17	12,5	-	27	15,5
LPCD 100-200/15	20	15	-	32	18,5

**TABELLA DATI ELETTRICI LPC4**

**4 Poli**

Modello	P <sub>2</sub>		Corrente assorbita [A]		
	[HP]	[kW]	230V	400V	690V
LPC4 40-100/0.25	0,33	0,25	1,6	0,9	-
LPC4 40-125/0.25 R	0,33	0,25	1,6	0,9	-
LPC4 40-125/0.25	0,33	0,25	1,6	0,9	-
LPC4 40-160/0.37	0,55	0,37	2,3	1,3	-
LPC4 40-200/0.75	1	0,75	3,9	2,25	-
LPC4 40-200/0.92	1,25	0,92	4,7	2,7	-
LPC4 50-125/0.25	0,33	0,25	1,6	0,9	-
LPC4 50-125/0.37	0,55	0,37	2,3	1,3	-
LPC4 50-160/0.55	0,75	0,55	2,8	1,6	-
LPC4 50-200/1.1 R	1,5	1,1	4,85	2,8	-
LPC4 50-200/1.1	1,5	1,1	4,85	2,8	-
LPC4 65-125/0.37	0,55	0,37	2,3	1,3	-
LPC4 65-125/0.55	0,75	0,55	2,8	1,6	-
LPC4 65-160/0.75	1	0,75	3,9	2,25	-
LPC4 65-160/0.92	1,25	0,92	4,7	2,7	-
LPC4 65-200/1.1	1,5	1,1	4,85	2,8	-
LPC4 65-200/1.5	2	1,5	6,6	3,8	-
LPC4 80-160/0.75	1	0,75	3,9	2,25	-
LPC4 80-160/0.92	1,25	0,92	4,7	2,7	-
LPC4 80-160/1.1	1,5	1,1	4,85	2,8	-
LPC4 80-160/1.5	2	1,5	6,6	3,8	-
LPC4 80-200/2.2	3	2,2	10	5,8	-
LPC4 80-200/3	4	3	13,5	7,8	-
LPC4 100-160/1.5	2	1,5	6,6	3,8	-
LPC4 100-160/2.2	3	2,2	10	5,8	-
LPC4 100-200/3	4	3	13,5	7,8	-
LPC4 100-200/4	5,5	4	16,1	9,3	-
LPC4 100-250/5.5	7,5	5,5	-	12	6,9
LPC4 100-250/7.5	10	7,5	-	15,6	9

## ELETTROPOMPE CENTRIFUGHE IN-LINE

in ghisa

TABELLA DATI ELETTRICI LPCD4

4 Poli

Modello	P <sub>2</sub>		Corrente assorbita [A]	
	[HP]	[kW]	230V	400V
	LPCD4 40-100/0.25	0,33	0,55	1,6
LPCD4 40-125/0.25 R	0,33	0,75	1,6	0,9
LPCD4 40-125/0.25	0,33	1,1	1,6	0,9
LPCD4 50-125/0.25	0,33	1,5	1,6	0,9
LPCD4 50-125/0.37	0,55	1,5	2,3	1,3
LPCD4 50-160/0.55	0,75	2,2	2,8	1,6
LPCD4 65-160/0.55	0,75	3	2,8	1,6
LPCD4 65-160/0.75	1	3	3,9	2,25
LPCD4 65-160/0.92	1,25	4	4,7	2,7
LPCD4 80-160/0.75	1	3	3,9	2,25
LPCD4 80-160/0.92	1,25	4	4,7	2,7
LPCD4 80-160/1.1	1,5	5,5	4,85	2,8
LPCD4 80-160/1.5	2	7,5	6,6	3,8
LPCD4 100-160/1.5	2	7,5	6,6	3,8
LPCD4 100-200/2.2	3	10	10	5,8
LPCD4 100-200/3	4	12,5	13,5	7,8
LPCD4 100-200/4	5,5	15	16,1	9,3
LPCD 100-200/12.5	17	12,5	-	27
LPCD 100-200/15	20	15	-	32