

End suction centrifugal pumps in accordance with EN 733 (ex DIN 24255) made of stainless steel **AISI 304** (3 series) and **AISI 316L** (3L series), applications include water boosting, heating systems, air-conditioning, washing systems and many other industrial applications.



SPECIFICATIONS

- Maximum working pressure: 10 bar
- Liquid temperature: from -10°C to $+90^{\circ}\text{C}$ ($+110^{\circ}\text{C}$ L - H - HS version)

MATERIALS

- Pump body, impeller, casing cover and shaft in AISI 304 (AISI 316 or bronze impeller for 3 series 65)
- Mechanical seal in carbon/ceramic/NBR for standard version (3BM/3M)
- Mechanical seal in carbon/ceramic/FPM for "H version" (3BHM/3MH)
- Mechanical seal on SiC/SiC/FPM for "HS version" (3BMHS/3MHS) and 3LM version as standard

TECHNICAL DATA

- Asynchronous 2 poles motor
- Insulation class F
- Protection degree IP 55
- Three-phase standard voltage: 220/380-460V $\pm 6\%$ (up to 4 kW)
380 \pm 460/660V $\pm 6\%$ (5,5 kW and above)
- Thermal protection to be provided by the user

Available in 5 different versions:

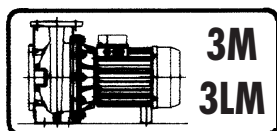

monobloc with extended motor shaft

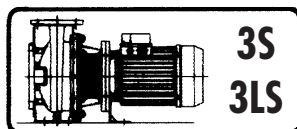

monobloc with standard motor and flexible coupling (on request)

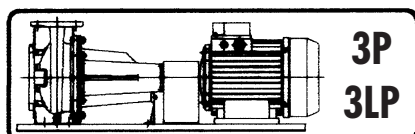

on base with standard motor and flexible coupling (on request)

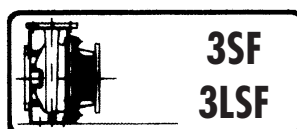
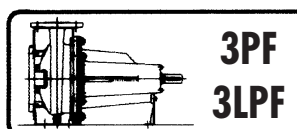

bare shaft pump

PERFORMANCE CHART at 3450 r.p.m. (according to ISO 9906 Annex A)

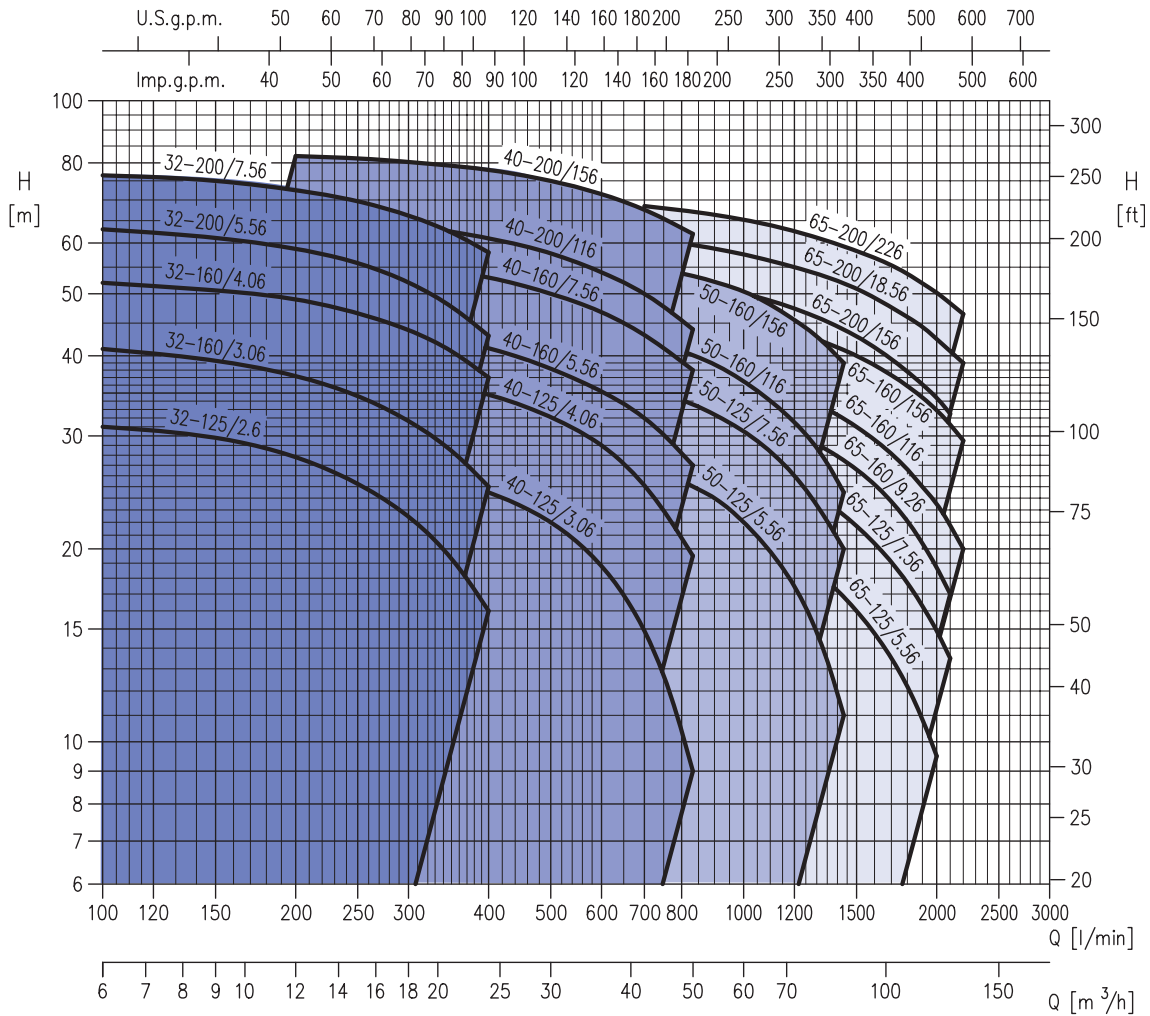

PERFORMANCE TABLE

Pump type 3M	Output kW HP		Absorbed current [A]			Q=Capacity																					
						Three-phase			H=Total manometric head in meters																		
						220V	380V	460V	0	100	150	200	250	300	350	400	500	600	700	833	1000	1200	1433	1800	2000	2100	2200
									0	6	9	12	15	18	21	24	30	36	42	50	60	72	86	108	120	126	132
3(L)M 32-125/2.26	2,2	3	6,6	3,8	3,7	32	31	30	28	25,5	22,5	19,3	16	-	-	-	-	-	-	-	-	-	-	-			
3(L)M 32-160/3.06	3	4	9,7	5,6	5,3	43	41	39,5	37	34,5	31,5	28,5	25	-	-	-	-	-	-	-	-	-	-	-			
3(L)M 32-160/4.06	4	5,5	13,9	8	7,5	53,5	52	50,5	49	46,5	44	40,5	37	-	-	-	-	-	-	-	-	-	-	-			
3(L)M 32-200/5.56	5,5	7,5	-	12,3	-	65	63	61	59	56	52	47,5	43	-	-	-	-	-	-	-	-	-	-	-			
3(L)M 32-200/7.56	7,5	10	-	15,2	-	78,5	76,5	75	72,5	69,5	66	62,5	58	-	-	-	-	-	-	-	-	-	-	-			
3(L)M 40-125/3.06	3	4	9,4	4,5	5,1	29	-	-	28	27,5	26,5	25,5	24,5	22	18,8	14,9	9	-	-	-	-	-	-	-			
3(L)M 40-125/4.06	4	5,5	14,7	8,5	7,9	39	-	-	38	37,5	36,5	36	35	32	29	25	19,5	-	-	-	-	-	-	-			
3(L)M 40-160/5.56	5,5	7,5	-	12	-	46,5	-	-	45	44	43,5	42,5	41	38	35	32	27	-	-	-	-	-	-	-			
3(L)M 40-160/7.56	7,5	10	-	15,4	-	58	-	-	57	56,5	55,5	54	53	50	47	43	38	-	-	-	-	-	-	-			
3(L)M 40-200/116	11	15	-	22,2	-	67	-	-	66	65	64	62,5	61	58	54	50	44	-	-	-	-	-	-	-			
3(L)M 40-200/156	15	20	-	27	-	83	-	-	82	81,5	80,5	79	78	75	71,5	67,5	62	-	-	-	-	-	-	-			
3(L)M 50-125/5.56	5,5	7,5	-	10,9	-	31,5	-	-	-	-	-	-	-	29	28	27	25	22	17,48	11	-	-	-	-			
3(L)M 50-125/7.56	7,5	10	-	14,9	-	38,5	-	-	-	-	-	-	-	37	36,5	35,5	33,5	30,5	26	20	-	-	-	-			
3(L)M 50-160/116	11	15	-	22,2	-	47,5	-	-	-	-	-	-	-	45	44	42,5	40	36,5	31,5	24,5	-	-	-	-			
3(L)M 50-160/156	15	20	-	27	-	58	-	-	-	-	-	-	-	57	56	55	53,5	50,5	45,5	39	-	-	-	-			
3(B)(L)M65-125/5.56	5,5	7,5	-	11,4	10,5	27,5	-	-	-	-	-	-	-	-	25,7	25	23,5	22	19,6	16,824	12,2	9,5	-	-			
3(B)(L)M65-125/7.56	7,5	10	-	15,4	13,9	33,5	-	-	-	-	-	-	-	-	31,5	30,5	29,47	28	25,5	22,5	17,7	14,9	13,5	-			
3(B)(L)M65-160/9.26	9,2	13	-	18,4	16,6	38	-	-	-	-	-	-	-	-	-	35,5	34,5	32,5	30,5	27,48	22	18,7	17	-			
3(B)(L)M65-160/116	11	15	-	21,3	18,7	43	-	-	-	-	-	-	-	-	-	40,5	39	37,5	35	32	26,5	23,5	22	20			
3(B)(L)M65-160/156	15	20	-	28,9	25,1	51	-	-	-	-	-	-	-	-	-	48,5	47,5	46	43,5	41	36	33	31,5	29,5			
3(B)(L)M65-200/156	15	20	-	29,3	25,7	56,5	-	-	-	-	-	-	-	-	-	53,5	52	50	47,5	43,98	38	34,5	32,5	-			
3(B)(L)M65-200/18.56	18,5	25	-	35,4	32,8	63,5	-	-	-	-	-	-	-	-	-	61	59,5	57,5	55	52	46	42,5	40,5	39			
3(B)(L)M65-200/226	22	30	-	41,7	36,7	71	-	-	-	-	-	-	-	-	-	68,5	67	65	62,5	59,5	53,5	50	48,5	46,5			

PERFORMANCE CURVES 3(L)M 32 (according to ISO 9906 Annex A)

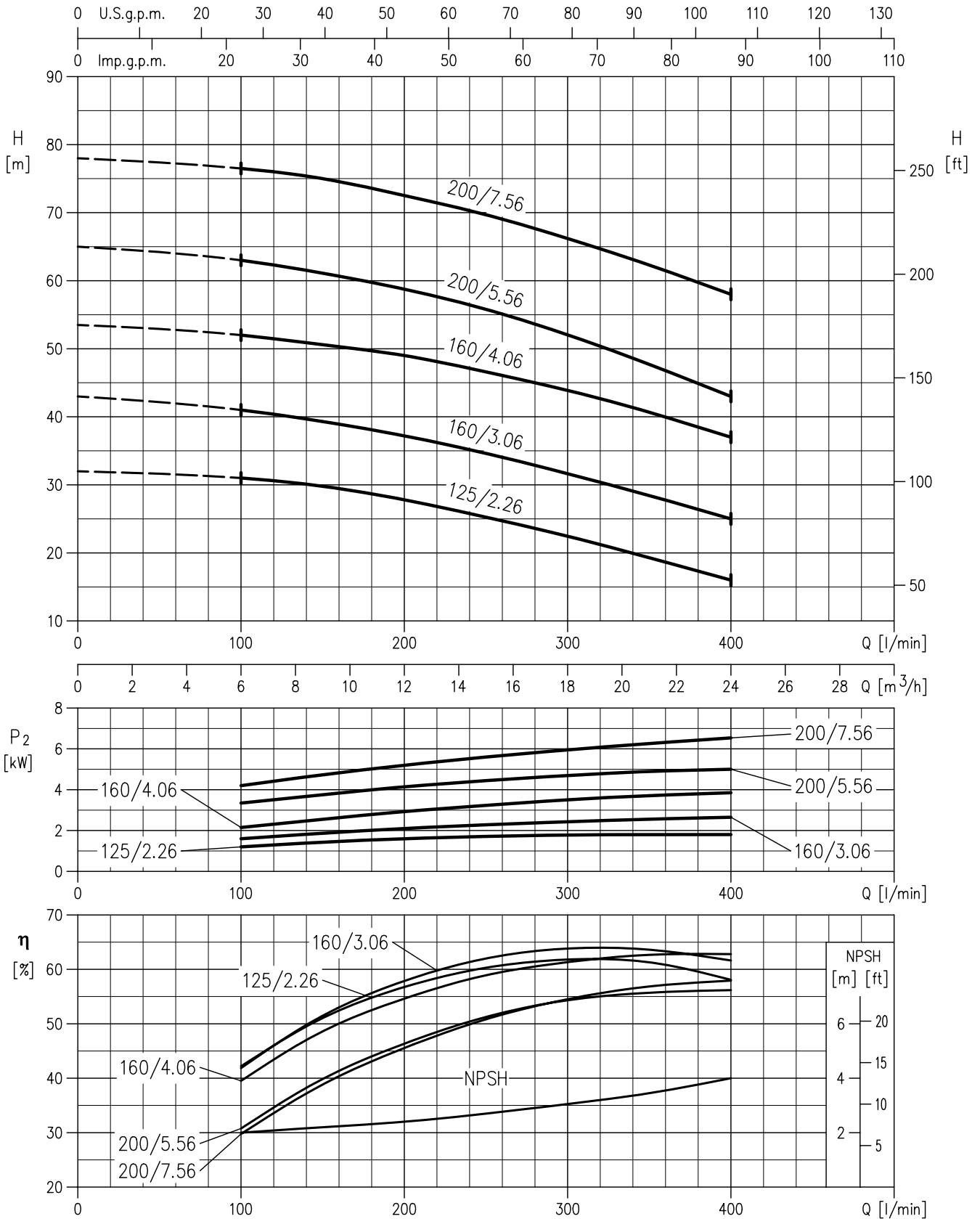

PERFORMANCE CURVES 3(L)M 40 (according to ISO 9906 Annex A)

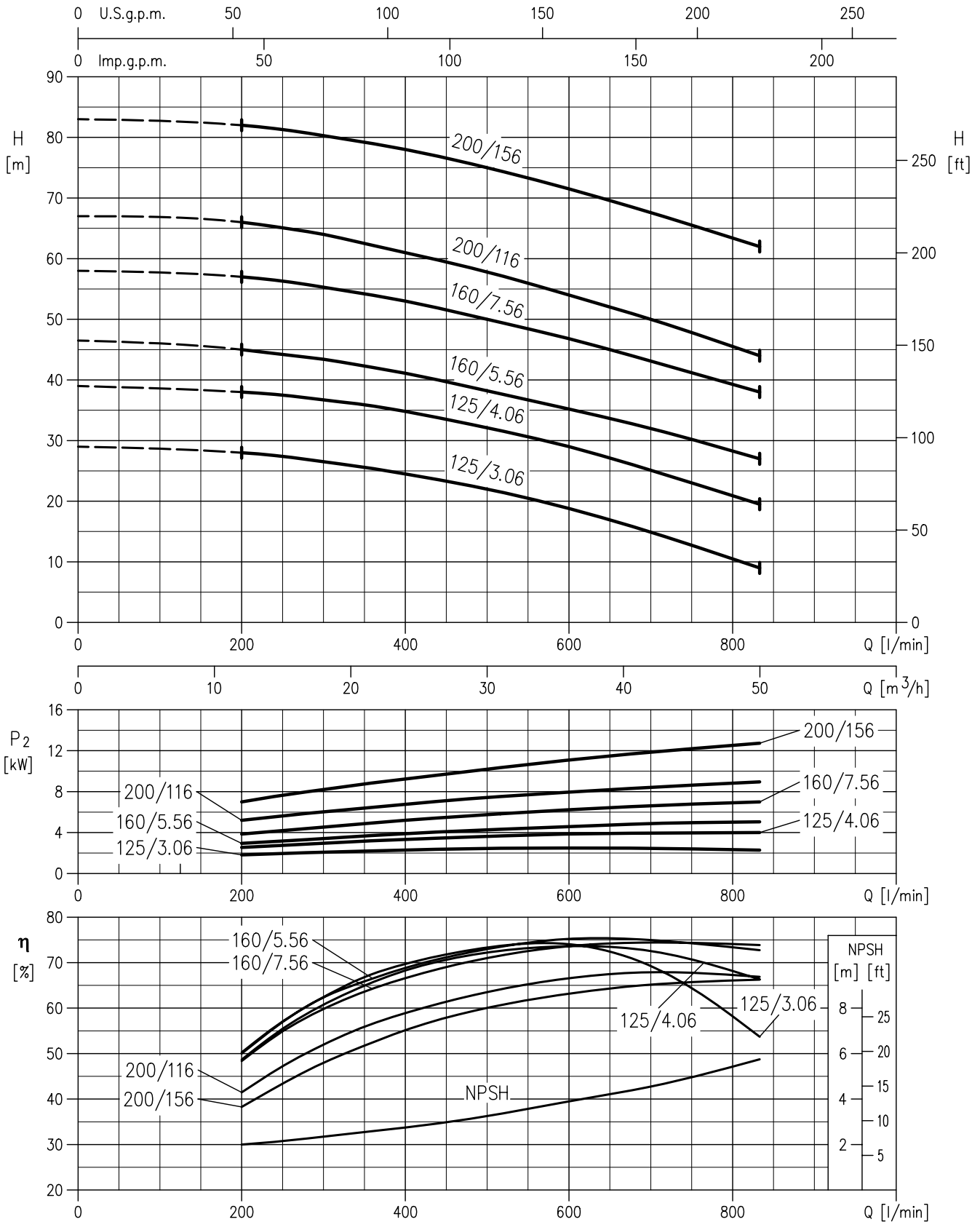

PERFORMANCE CURVES 3(L)M 50 (according to ISO 9906 Annex A)

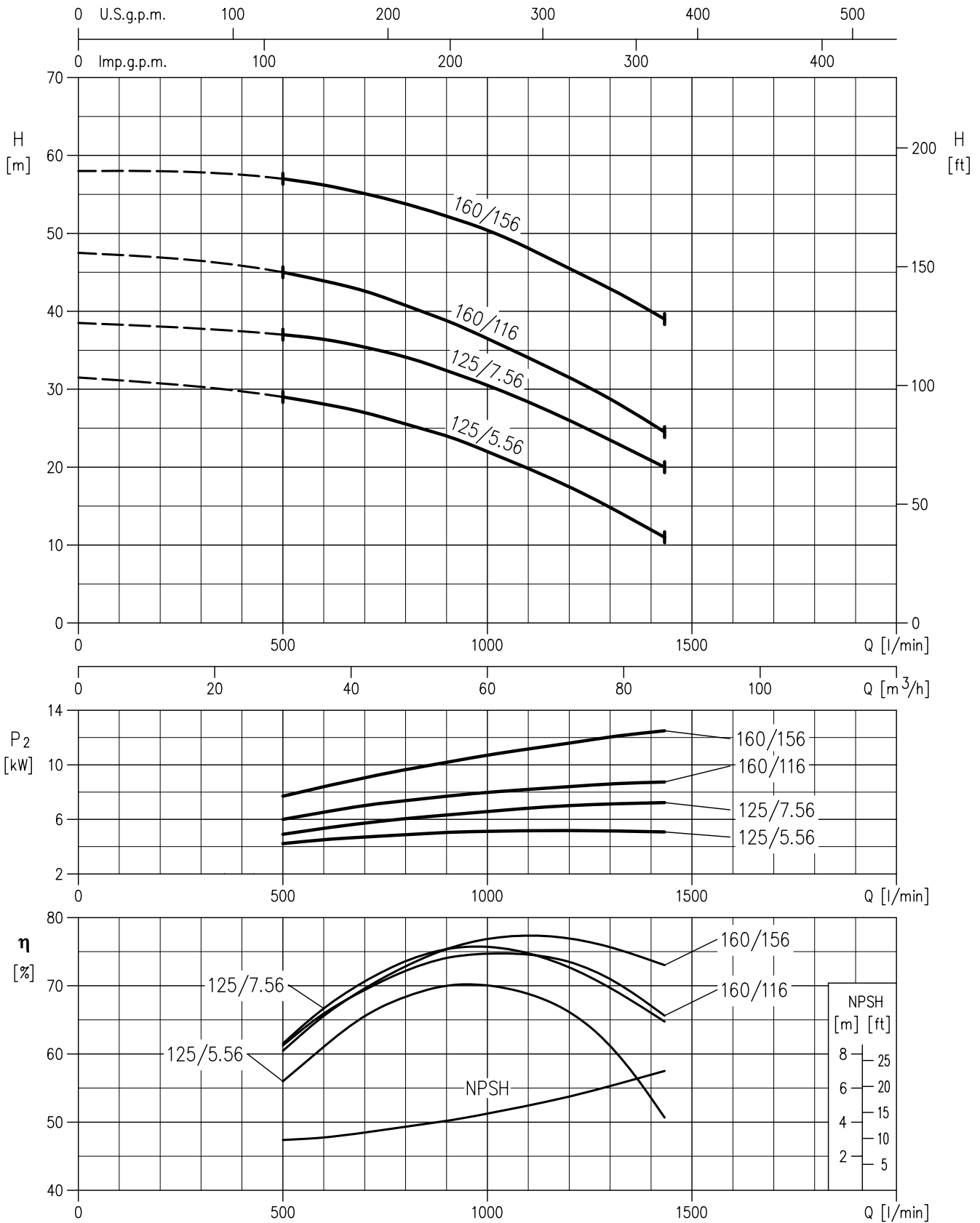

PERFORMANCE CURVES 3(L)M 65 (according to ISO 9906 Annex A)

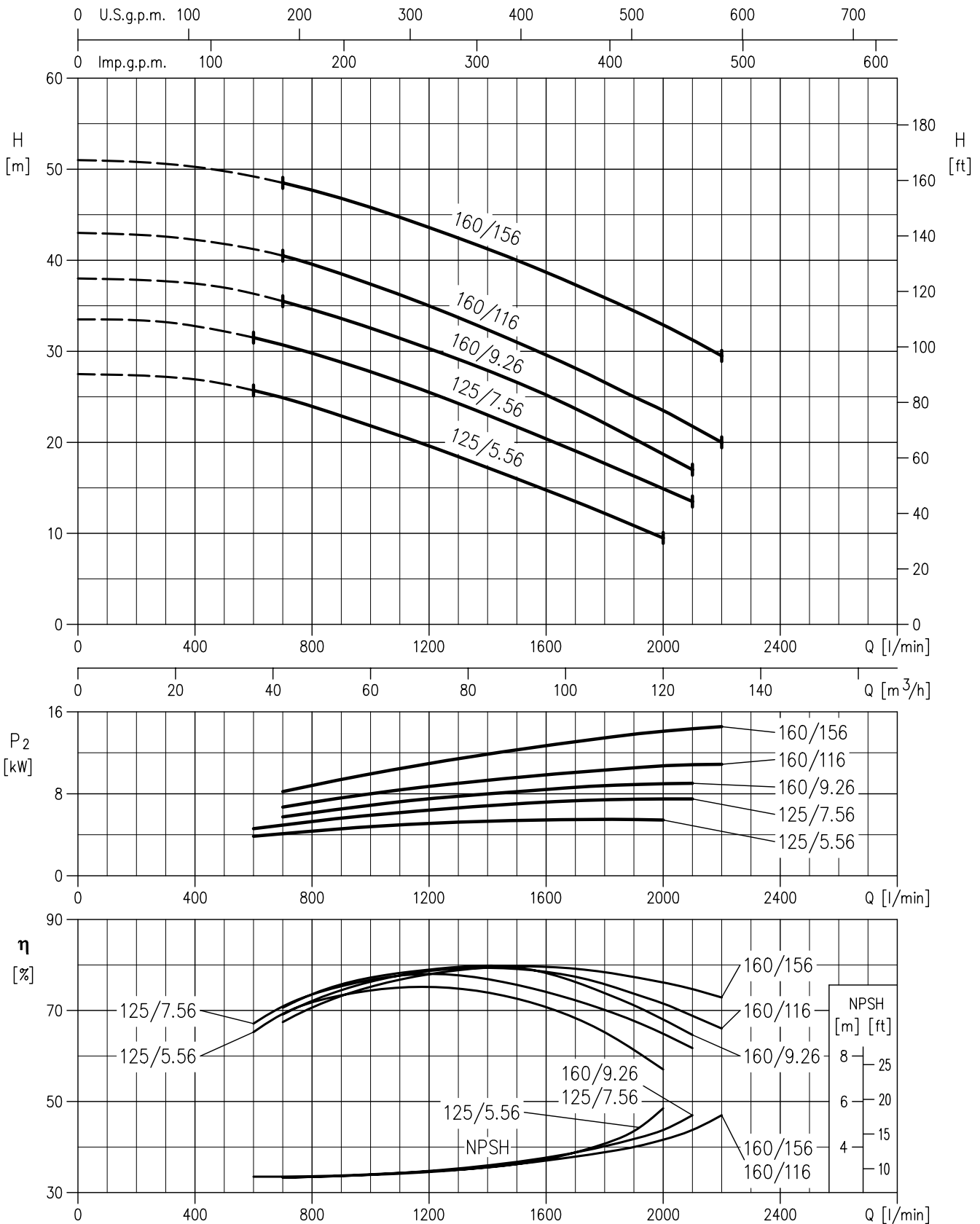

PERFORMANCE CURVES 3(L)M 65 (according to ISO 9906 Annex A)

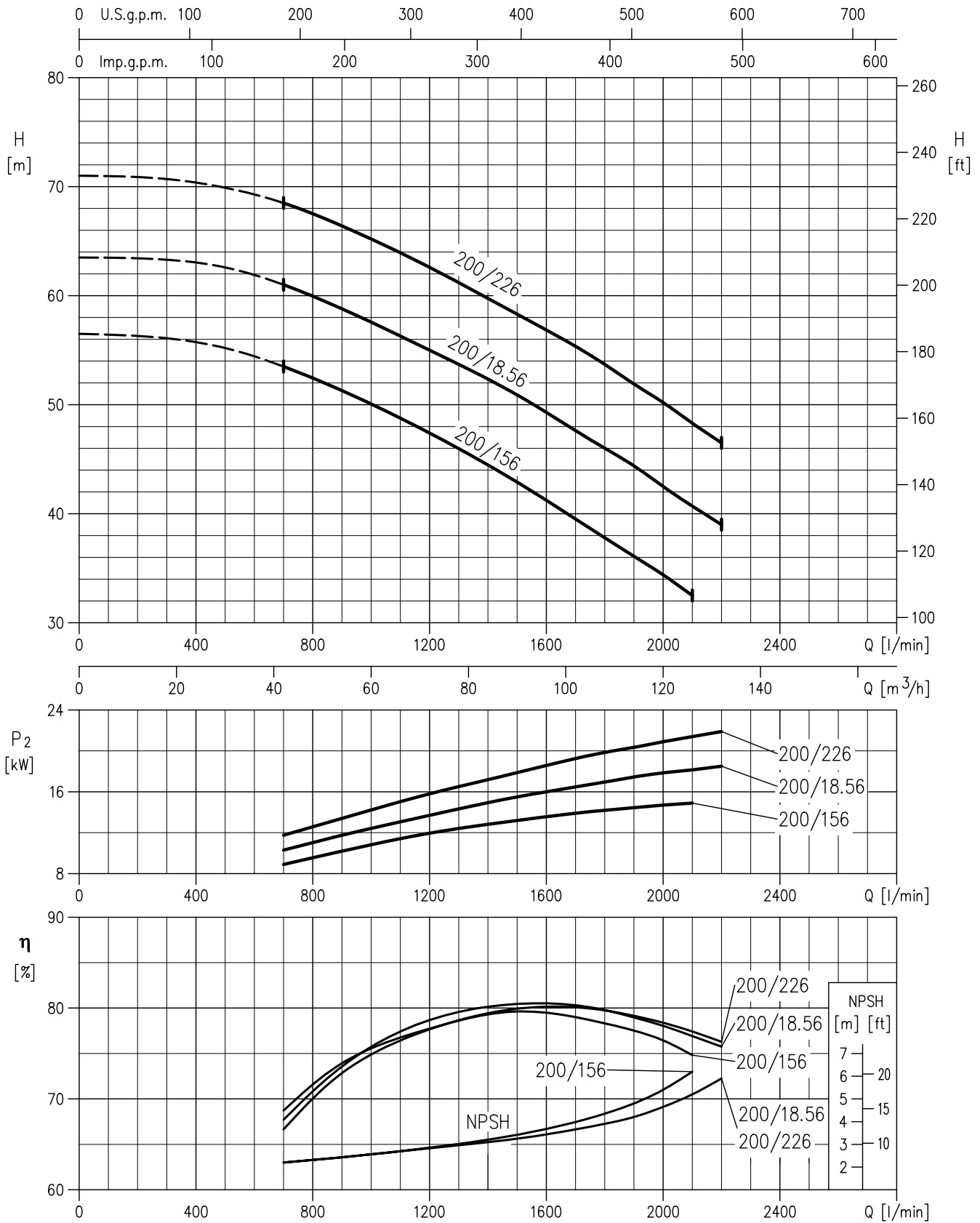

DIMENSIONS: 3M (3LM) up to 11 kW

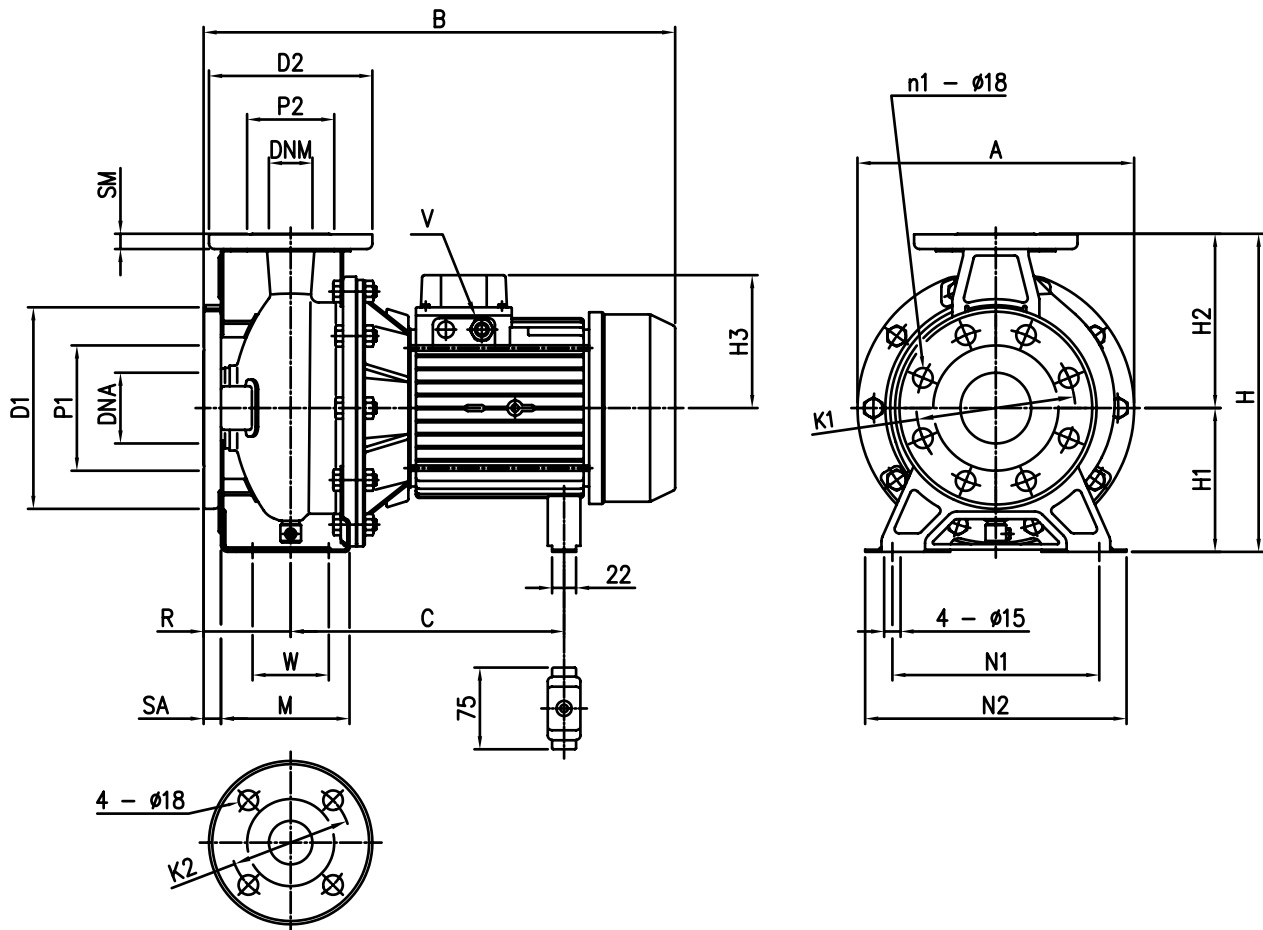

DIMENSIONAL TABLE

Model	Weight [kg]	Dimensions [mm]																								
		∅ DNA	∅ P1	n1 [1] [2]	∅ K1	∅ D1	SA	∅ DNM	∅ P2	∅ K2	∅ D2	SM	H	H1	H2	H3	R	W	N1	M	N2	A	B	C	V	
3(L)M 32-125/2.26	23												252	112	140	122			140	114	190	213	407	230	PG 13.5	
3(L)M 32-160/3.06	28,3												292	132	160	134			190	118	240	254	432	255		
3(L)M 32-160/4.06	35	50	96		125	165		32	76	100	140		340	160	180	153			190	119	240	296	477	275	PG 16	
3(L)M 32-2005.56	48,3												340	160	180	153			190	119	240	296	477	275	PG 16	
3(L)M 32-200/7.56	58												340	160	180	153			190	119	240	296	477	275	PG 16	
3(L)M 40-125/3.06	25,6											14	252	112	140	122			160	114	210	213	432	255	PG 13.5	
3(L)M 40-125/4.06	31,6			4			16						252	112	140	134			160	114	210	213	432	255	PG 13.5	
3(L)M 40-160/5.56	42,3							40	81	110	150		292	132	160	153			190	118	240	254	475	275	PG 16	
3(L)M 40-160/7.56	50,3												292	132	160	153			190	118	240	254	475	275	PG 16	
3(L)M 40-200/116	61,3	65	116		145	185							340	160	180	181			212	139	265	296	577	224	PG 21	
3(L)M 50-125/5.56	43,8												292	132	160	153			190	138	240	254	494	275	PG 16	
3(L)M 50-125/7.56	50,5							50	96	125	165		292	132	160	153			190	138	240	254	538	275	PG 16	
3(L)M 50-160/116	62												340	160	180	181			212	139	265	296	593	356	PG 21	
3(B)(L)M 65-125/5.56	50											16	340	160	180	150			190	138	240	254	494	275	PG 16	
3(B)(L)M 65-125/7.56	52,6												340	160	180	150			190	138	240	254	494	275	PG 16	
3(B)(L)M 65-160/9.26	63,6	80	134	8	4	160	200	18	65	115	145	185	360	160	200	177,5			95	212	150	280	296	593	356	PG 21
3(B)(L)M 65-160/116	70												360	160	200	177,5			95	212	150	280	296	593	356	PG 21

DIMENSIONS: 3M (3LM) up to 22 kW

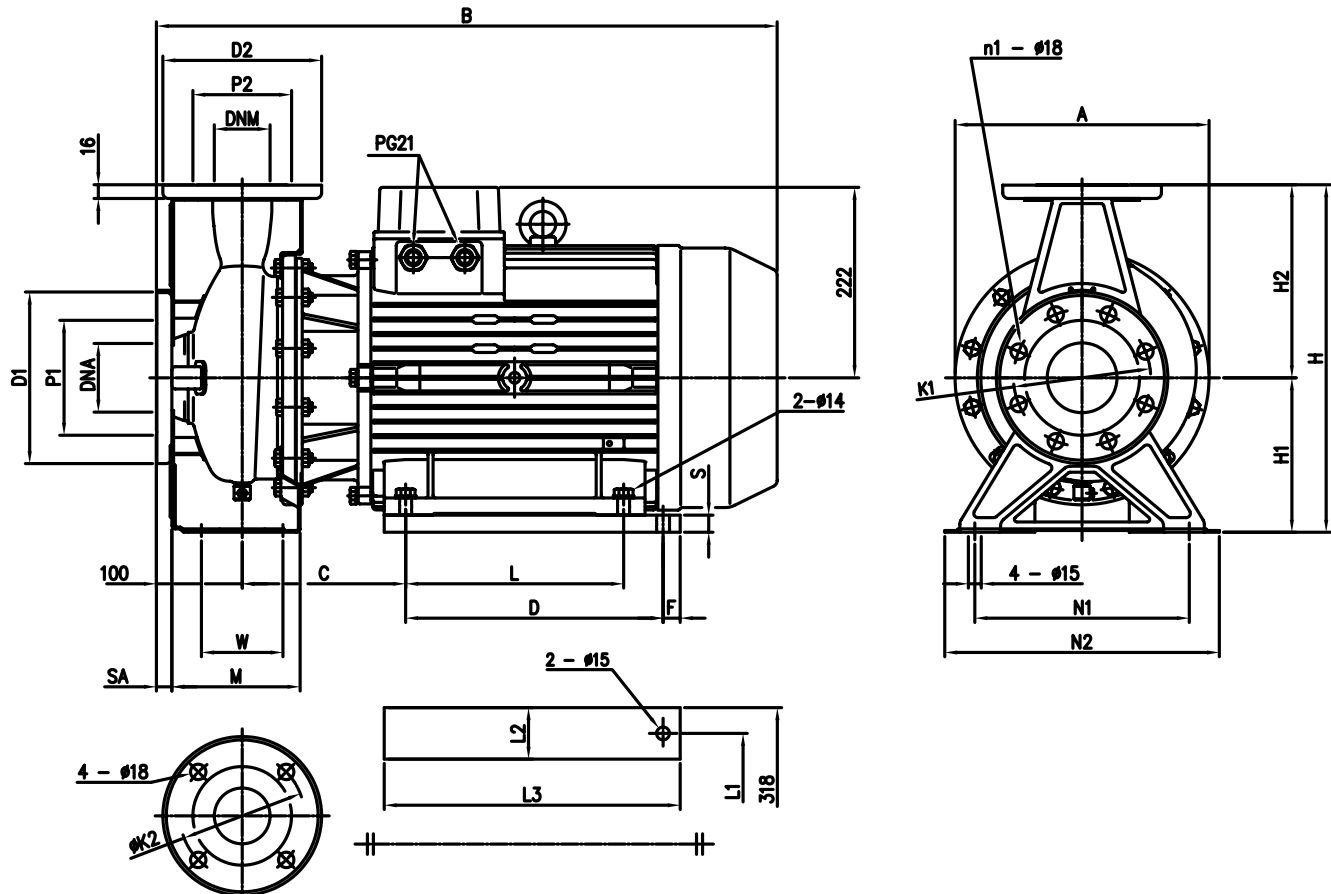

PERFORMANCE TABLE

Pump type	Weight [kg]	Dimensions [mm]																							
		\emptyset DNA	\emptyset P1	n1 [1] [2]	\emptyset K1	\emptyset D1	SA	\emptyset DNM	\emptyset P2	\emptyset K2	\emptyset D2	H	H1	H2	W	N1	M	N2	A	B	L	L1	L2	L3	
3(L)M 40-200/156	73,5	65	116	4	-	145	185	16	40	81	110	150	340	160	180	70	212	139	265	296	724	254	254	65	304
3(L)M 50-160/156	73								50	96	125	165	360	200											
3(B)LM65-160/156	103																								
3(B)LM65-200/156	106	80	134	8	4	160	200	18	65	115	145	185	405	180	225	95	250	150	320	296	733	-	258	60	345
3(B)LM65-200/18.56	120																								
3(B)LM65-200/226	128																								

[1] = Standard
[2] = On request